

T ECHNICAL INFORMATION



New Tool

Models No. ▶ 1911B

Description ▶ MAKITA 110 mm Planer

CONCEPTION AND MAIN APPLICATIONS

The small and light weighing model having the double insulation structure with the planer knife width 110 mm or the middle type between the existing planer knife width 82 mm and 136 mm, should be developed.

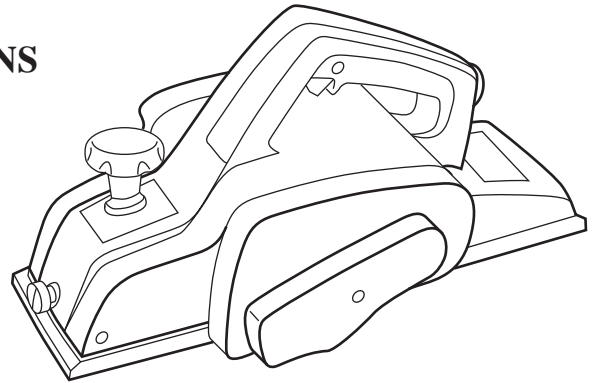

▶ Specifications

Voltage(V)	Current(A)	Frequency(Hz)	Consumed power(W)
Single-phase 100	9	50-60	840

No load speed (/min.)		16000
Capacity(mm)	Max. cutting width	110
	Max. cuttingdepth	2
Overall dimension		355mm in overall length x 175mm in width x 175mm in height
Weight(kg)		4.2
Cord length(m)		5

▶ Standard equipment

- Knife stone holder ----- One piece ----- For grinding the planer knife
- Ruler for adjusting the knife height ----- One piece ----- For adjusting planer knife
- Box wrench ----- One piece ----- For assembling/disassembling the planer knife

▶ Optional accessories

- Ruler----- For adjusting cutting
- Carbide planer knife----- For cutting the hard wood

The standard equipment for the tools shown may differ from country to country.

► **Repair**

Same as the conventional planer.