

TECHNICAL INFORMATION



Models No. ▶ 1923H

Description ▶ MAKITA 82 mm Electrical planer

CONCEPTION AND MAIN APPLICATIONS

In reply to the request from European market, the power has been upgraded than #1923B while the price is maintained at the same level. This equipment is for export exclusive purpose.

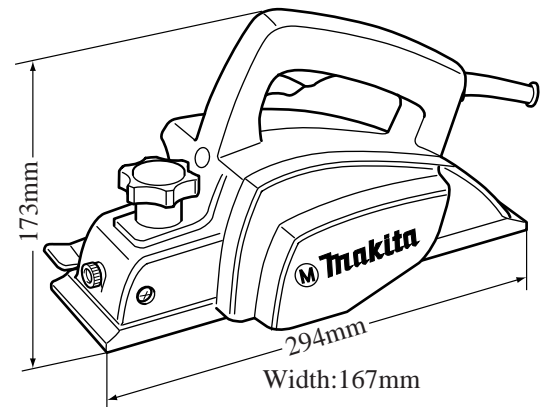

► Specifications

Voltage(V)	Current (A)	Frequency(Hz)	Continuous rating		Max. Output(W)
			Input(W)	Output(W)	
100	9	50-60	850	470	1100
115	7.8	50-60	850	470	1100
200	4.5	50-60	850	470	1100
230	4.1	50-60	850	470	1100
230	3.9	50-60	850	470	1100
240	3.0	50-60	850	470	1100

Motor	AC Universal motor
No load speed (Rotation,)	16000/min.
Max. cutting width	82 mm
Max. cutting depth	3.5 mm
Shiplapping	23 mm

► Standard equipment

Blade grinder holder	1
Blade gauge	1
+ Screw driver	1
Box wrench 9	1
Ruler	1

► Optional accessories

Planer stand, Dust bag, wet stone 150-1200, Nozzle assembly

The standard equipment for the tools shown may differ from country to country.

▶ **Repair**

Same as 1923B.