

**For Models** ▶ 2412N

**Description** ▶ 305MM/355MM PORTABLE CUT-OFF

## CONCEPTION AND MAIN APPLICATIONS

The #2412N is the remodeled type of #2412 and the design is renewed, which has been developed while aiming at low cost, easy-to-use and safety to satisfy the request from the sales field.

Also, the #2414 is the sister version of it, wherein the grindstone with diameter 355 mm is installed compared with the #2412N with 305 mm to cope with the users' demand for much larger diameter grindstone.

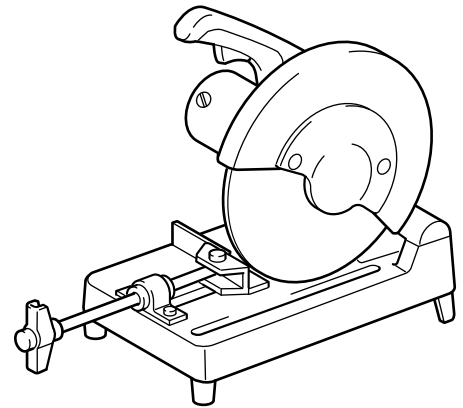

### ► Specifications

<b>Motor</b>		Series commutator motor
<b>Voltage</b>		Single phase 100V
<b>Cycle</b>		50/60Hz
<b>Consumed power</b>		1450W
<b>No Load Speed</b>		3800r.p.m
<b>Wheel Dia. <math>\phi</math></b>	<b>#2412N</b>	305mm
	<b>#2414</b>	355mm
<b>Max. cutting capacities</b>	<b>at 90 degrees</b>	$\phi$ 100mm W 190 mm
	<b>at 45 degrees</b>	$\phi$ 100mm W 100 mm
<b>Net Weight</b>	<b>#2412N</b>	15.7kg
	<b>#2414</b>	17kg
<b>Cord length</b>		5m

### ► Standard equipment

- #2412N Box wrench 17 --- 1pc.  
Cut-off-wheel 305 ---1pc.
- #2414 Box wrench 17 --- 1pc.  
Cut-off-wheel 355 ---1pc.

### ► Optional accesories

- Cut-off-wheel 305(5-pc.--- one set)
- Cut-off-wheel 355 (5-pc.--- one set)