

T ECHNICAL INFORMATION



New Tool

Models No. ▶ 2414B

Description ▶ 355 mm (14") Portable Cut-off

CONCEPTION AND MAIN APPLICATIONS

Model 2414B is a redesigned version of the existing Model 2414 and equipped with a unique tool head slide system. This system helps increase cutting efficiency and keep wheel from loading.

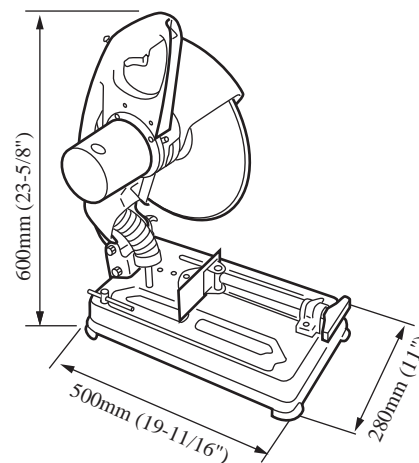

► Specifications

Voltage (V)	Current (A)	Cycle (Hz)	Continuous Rating (W)		Max. Output(W)
			Input	Output	
100	15.0	50/60	1,430	750	1,900
115	15.0	50/60	1,650	900	2,400
200	7.5	50/60	1,430	750	1,900
220	9.6	50/60	2,000	1,200	3,300
230	9.2	50/60	2,000	1,200	3,300
240	8.8	50/60	2,000	1,200	3,300

Wheel Diameter	355 mm (14")
Arbor Diameter	25.4 mm (1")
No Load Speed	3,800 R/min
Net Weight	16.3 kg (35.9 lbs)

► Cutting Capacities:

Cutting Angle	Workpiece Shape			
	90	115 mm (4-1/2")	122 mm (4-13/16")	115 mm x 142 mm (4-1/2"x5-9/16") 102 mm x 197 mm (4" x 7-3/4") 70 mm x 240 mm (2-3/4" x 9-7/16")
45	115 mm (4-1/2")	106 mm (4-3/16")	115 mm x 106 mm (4-1/2" x 4-3/16")	100 mm (3-15/16")

► Standard equipment

Socket Wrench 17

► Optional accessories

Abrasive Cut-off Wheel No.10 , No.12

The standard equipment for the tools shown may differ form country to country