

TECHNICAL INFORMATION



PRODUCT
P 1 / 4

Models No. ▶ 2414NB

Description ▶ 355mm(14") Portable Cut-off

CONCEPT AND MAIN APPLICATIONS

Model 2414NB is the sister version of the existing Model 2414B without swing action.

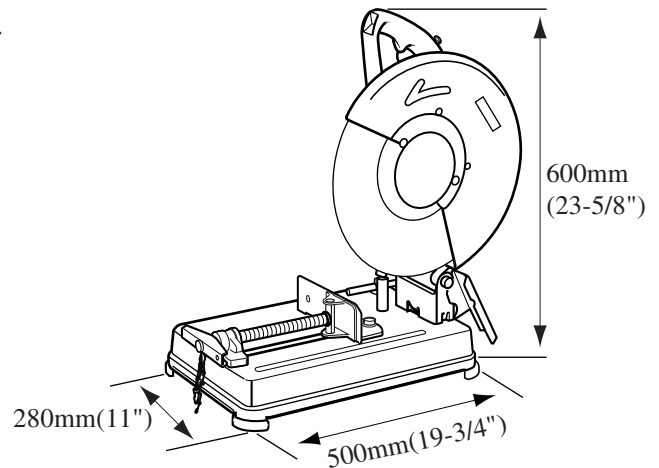

► Specifications

Voltage (V)	Current (A)	Cycle (Hz)	Continuous Rating (W)		Max. Output(W)
			Input	Output	
100	15.0	50/60	1430	750	1900
115	15.0	50/60	1650	900	2400
220	9.6	50/60	2000	1200	3300
230	9.2	50/60	2000	1200	3300
240	8.8	50/60	2000	1200	3300

No Load Speed		3800rpm
Wheel size	Arbor diameter	25.4mm(1")
	Wheel diameter	355mm(14")
	Thickness	3mm(1/8")
Net weight		16.2Kg(35.7lbs) with wheel
Cord length		2.5m(8.2ft)

Cutting capacities

Cut-off Angle	Round stock	Rectangular stock	Square stock	L-shape stock
90°	115mm(4-1/2")	102x194mm(4"x7-5/8") 70x233mm(2-3/4"x9-1/8")	119mm(4-11/16")	137mm(5-3/8") t=10mm(3/8")
45°	115mm(4-1/2")	115x103mm(4-1/2"x4-1/16")	119mm(4-11/16")	100mm(3-15/16") t=10mm(3/8")

► Standard equipment

Socket Wrench 17----- 1 pc.

Switch Button----- 2 pcs. (for North America, Europe, Australia and New Zealand)

<Note>The standard equipment may differ from country to country.

► Optional accessories

Abrasive Cut-off Wheel 355 (5 pcs. /pk., No. 10, for steel)

Abrasive Cut-off Wheel 355 (5 pcs./pk., No.12, for concrete)

Abrasive Cut-off Wheel 355 (5 pcs. /pk., No. 14, for steel)

► Features and benefits

1.Double insulated

2.See the sheets attached for more information.

The standard equipment for the tools shown may differ from country to country.

► Repair

For repairing methods, proceed in the same orders as 2414B except for swinging function at support point of 2414B.

1. Disassembling of the handle and switch

The handle R/L are fixed with 4 pieces of tapping screws and are mounted on the gear housing with the 3 pan head screws M5. To disconnect the handle L, disconnect these 7 screws. See the figure for the switch structure.

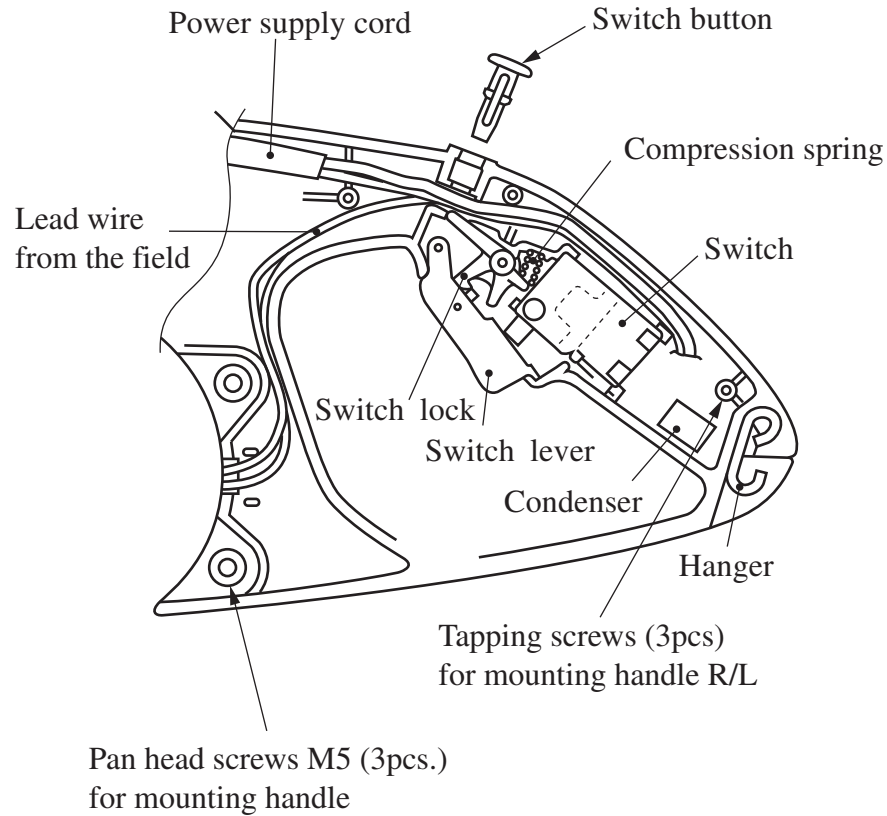

Unless the motor housing has been removed, the handle R cannot be disconnected. To disconnect the handle R, first remove the motor housing. (See 2. Disassembling of the motor.)

2. Disassembling of the motor

After removing the carbon brush (2pcs), remove the pan head screws M5(4 pieces) for mounting the motor housing and pan head screws M5 (3pcs) for mounting the handle to separate the one body of motor housing and handle from the gear housing, and then you can take away the armature.

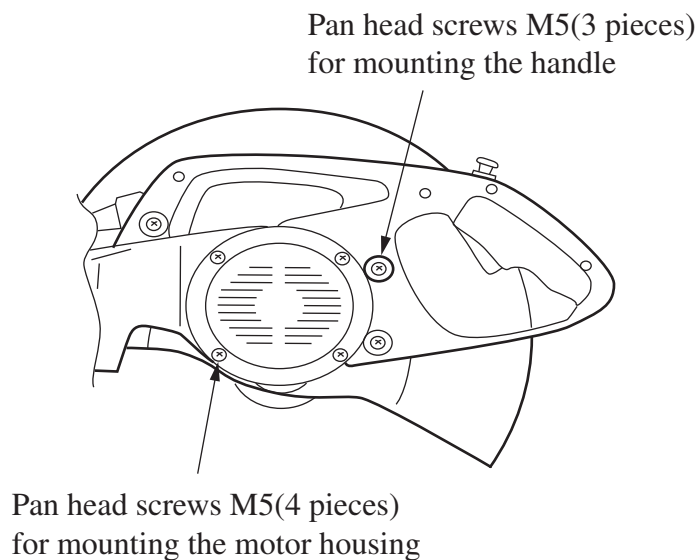

► Repair

3. Disassembling of the gear

Unless the safety cover has been disconnected, the gear cannot be disassembled. To disconnect the safety cover, after removing the hexagon bolt M10x25, outer flange, wheel stone, O ring, Ring 17 and inner flange, remove the pan head screws M6(4 pieces) for mounting the safety cover. Pull out the spindle to disconnect the gear. The two faces on the gear are protected from turning. To assemble the gear, make fit of the two faces of gear and spindle.

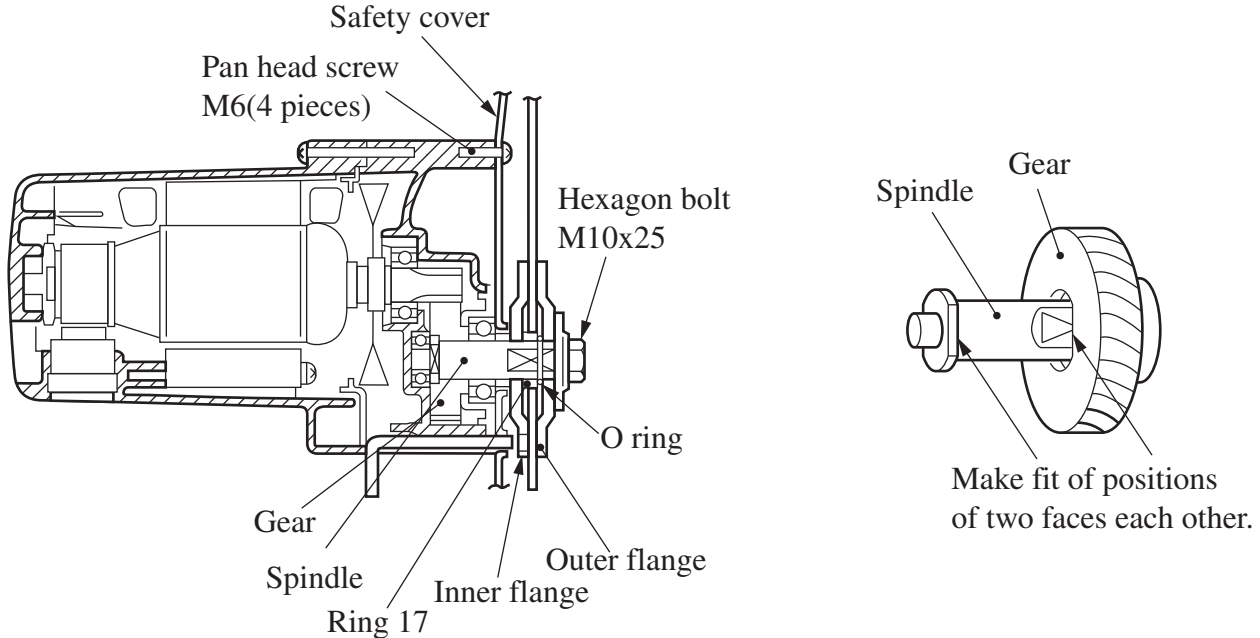

4. Disassembling of compression spring

Remove the hexagon holed bolts (for stopping the top dead center) mounted on the hinge while hanging (in transportation) the chain on the hanger at rear of handle. Lift up the gear housing little by little to extend the compression spring. If the compression spring has been extended up to the position as shown on the right figure, remove the hexagon bolt M10 with step in a way like lifting up the spring holder.

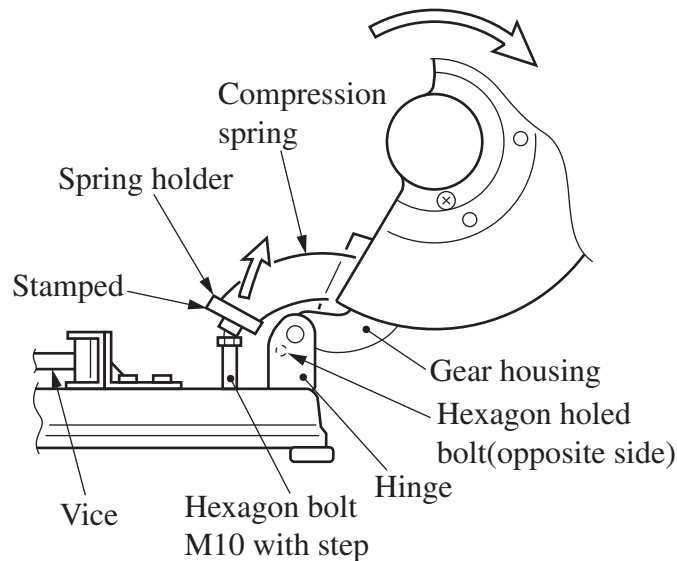

Note: The spring holder has a direction. When assembling, arrange in a way that the side with stamped mark may come at vice side.

► Circuit drawing

The condenser and line filter are not used in some areas.

