

TECHNICAL INFORMATION



PRODUCT

P 1 / 11

Model No. ▶ 2704

Description ▶ Table Saw 255mm (10")/ 260mm (10-1/4")
Europe: 260mm Other countries: 255mm (10")

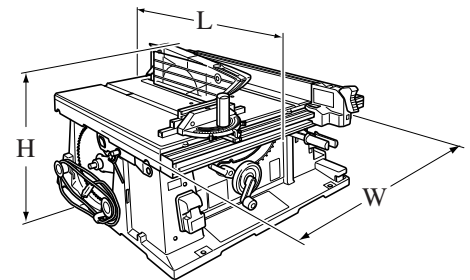

CONCEPT AND MAIN APPLICATIONS

This is a sister model ranked higher than our current table saw model 2703. The right sub table extends to rip cutting capacity of 4'x8' material. The other main different features are below.

- * Large machined aluminum table top for accurate cutting work
- * Precision rip fence provides accuracy
- * Powerful 1650W motor

Dimensions: mm (")		
	Europe, Turkey, South Africa	The others
Length (L)	760 (30)	665 (26-1/4)
Width (W)	766 (30-1/4)	
Height (H)	344 (13-1/2)	

► Specification

		Europe, Turkey, South Africa	Canada, USA, Mexico, Panama	The others
Saw Blade: mm (")	Diameter	260 (10-1/4)	255 (10)	
	Hole diameter	30 (1-3/16)	15.88 (5/8)	25.4 (1)
Continuous rating input: W		1,650		
Rated amperage for North America: A		15		
No load speed: min.-1=rpm		4,800		
Bevel cutting capacity: degrees		From minus 0.5 to plus 45.5		
Cutting capacity: mm (")	at 90 degrees	93 (3-5/8)	91 (3-5/8)	
	at 45 degrees	64 (2-1/2)	63 (2-1/2)	
Table size (WxL): mm (")	Main table	625x567 (24-5/8x22-1/4)		
	Sub table	128x570 (5x22-1/2)		
Max. width of dado: mm (")		21 (13/16)		
Electronic feature	Constant speed control	No		
	Soft start	UK 110V and all 220V-240V countries: Yes All 110V-127V countries except UK: No		
Electric brake		Yes		
Double insulation		Yes		
Power supply cord: m (ft)		2.5 (8.2)	2.5 (8.2) / Australia and New Zealand: 2.0 (6.6)	
Net weight: kg (lbs)		33 (72)	28 (61)	

► Standard equipment

TCT saw blade 1	Rip fence..... 1	Hex wrench 5..... 1	Ring 15.8 (257060-5) for use of 25.4mm inner diameter blade exclusively
Rear table set (exclusively Europe, Turkey, South Africa)..1	Miter gauge 1	Push stick 1	Canada, USA, Mexico and Panama..... 1
	Right table set 1	Joint for connecting a hose (exclusively Europe, Turkey, South Africa) 1	Ring 16 (257022-3) for use of 25mm inner diameter blade1 (It does not come with the products for Canada, USA, Mexico, Panama, Europe, Turkey and South Africa)
	Wrench 19 1		
	Socket wrench 13-22 ..1		

► Optional accessories

Stand set 1	Ring 15.8 (257060-5) for use of 25.4mm (1") inner diameter blade..... 1	The components of Dado head set and the relevant parts (Exclusively Canada, USA, Mexico and Panama: See instruction manual)..... 1
Left table set 1	Ring 16 (257262-3) for use of 30mm inner diameter blade1	
Rear table set..... 1	Ring 16 (257022-3) for use of 25mm inner diameter blade1	
Joint for connecting a hose.....1		
Sliding guide set 1		

Note: The standard equipment and the optional equipment for the tool shown above may differ from country to country.
Ring 15.8 (257060-5) or Ring 16 (257262-3) is factory-assembled for some countries.

► Repair

CAUTION: Be sure to unplug the tool before maintenance or repair.
See the instruction manual on how to handle the tool.

[1] Repairing tool

- Phillips bit No.3 and Cordless impact driver.....For M6 Pan head screws
 45 Degrees set square F/LS-models (Makita part No. 1R207)For setting Saw blade angle at 45° to Table
 90 Degrees set square F/LS-models (Makita part No. 1R208)For setting Saw blade angle at 90° to Table
 Bearing extractor (Makita part No. 1R263).....For separating Ball bearing 609LLB from Spindle complete
 Spring pin extractor 4.0 (Makita part No. 1R308).....For removing Spring pin 4-20 in Straight bevel gear

[2] Lubrication

- 1) Be sure to apply Makita grease N. No.1 (total 13g) to the gear portions.
- 2) Apply a little amount of grease to the contact surfaces designated by ▽ marks in **Fig.1**.
 (Makita grease N. No.1 is applied to the contact surfaces in our factory. Except for the gear portion, any greases is applicable.)

Fig. 1

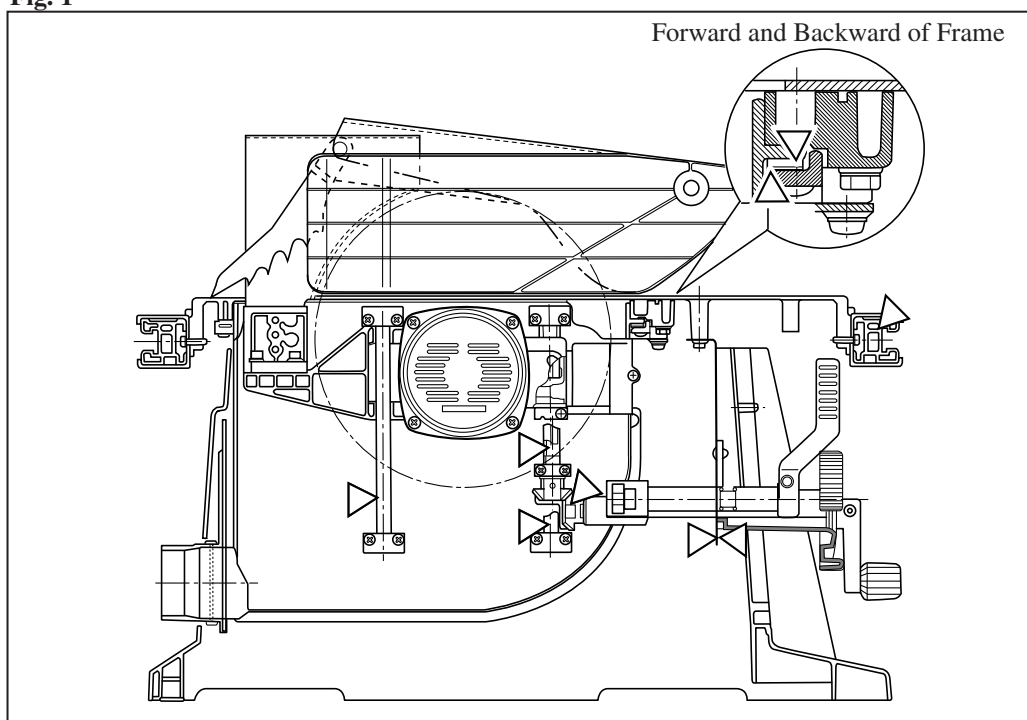

[3] Disassembling Motor portion

- Remove Slide cover and Riving knife.
 Spread cushions on the ground, put Table saw upside down on the cushions.
 Pay careful attention not to damage the table surface.
 Remove Base under cover installed only for European specifications.
 After separating four M6x60 Pan head screws from Motor housing complete, pull out the Motor housing portion.
Note: Do not lose Flat washer 18 because it often drops off while pulling out the Motor housing portion.
 Consequently, Armature can be pulled out by hand.

[4] Assembling Motor portion

- After installing drive-end of Armature ass'y to Gear housing complete, cover them with Baffle plate.
 Glue Flat washer 18 and Urethane washer 18 to Ball bearing 6000DDW (the component of Armature ass'y) using grease. It prevents drop of the flat washer and Urethane washer from Armature ass'y during assembling work. See **Fig. 2** .
 Insert Motor housing portion over them carefully to the direction of Motor housing complete and Gear housing complete. Refer to **Fig. 3** of next page.

Fig. 2

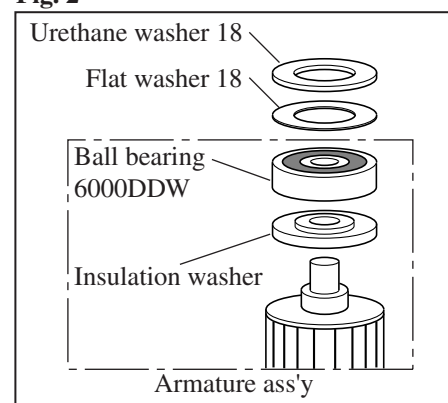

► **Repair**

Fig.3

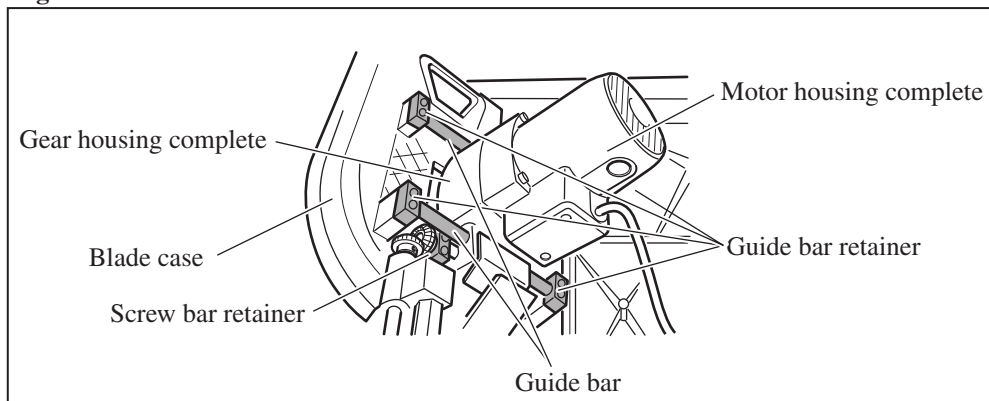

[5] Disassembling Spindle complete (Gear portion)

Note: Spindle complete (Fig.4) is replaceable without disassembly of Motor housing complete.

Ball bearing 6203DDW and Helical gear 42 are press-fit to Spindle at proper torque in our factory.

Therefore, if something is wrong with the Spindle complete, replace it entirely with a new one.

Remove (1) four Guide bar retainers (2) two Guide bar (3) Screw bar retainer in this order. Refer to **Fig.3**. Separate Gear housing complete with Motor housing complete from Frame as described in **Fig.5**.

Fig.4

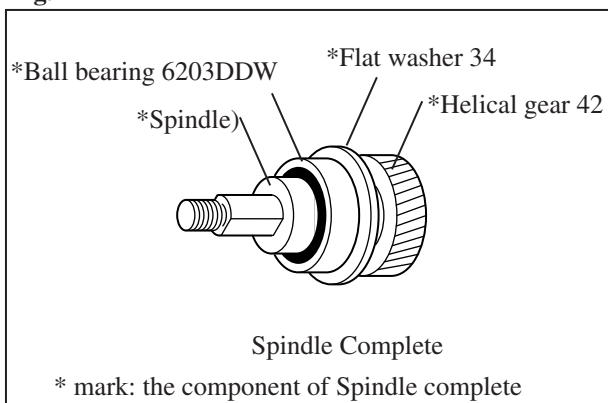
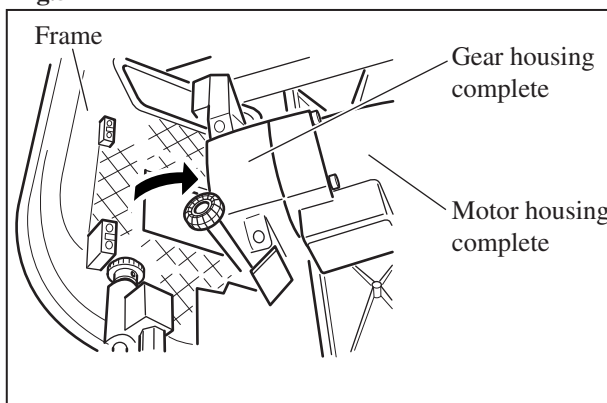

Fig.5



Remove four M5x20 Pan head screw for securing Bearing box to Gear housing complete, then pull out Gear portion.

Insert two edges of 1R263 into the clearance between Helical gear 42 and Ball bearing 609LLB, lever the ball bearing 609LLB from Spindle complete end using the 1R263 as illustrated in **Fig.6**.

Separate Bearing box from Spindle complete.

Finally, replace Spindle complete by new one.

Caution when assembling Spindle complete (Gear portion)

Align a notch of Bearing box with one edge of Gear housing complete as mentioned in **Fig.7**.

Fix bearing box to Gear housing complete using four M5x20 Pan head screws.

Fig.6

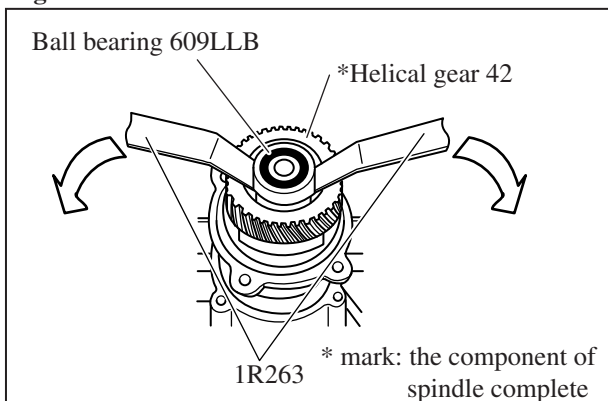
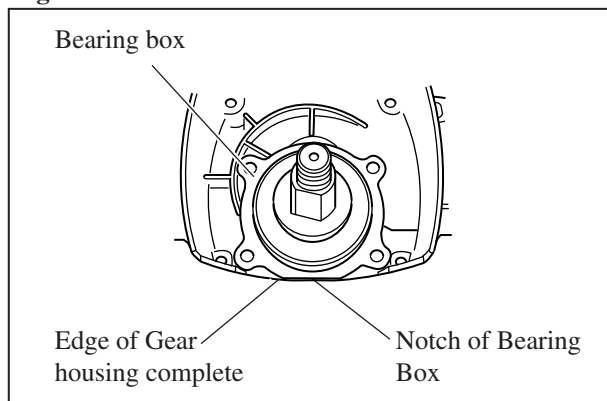

Fig.7



► Repair

[6] Disassembling Base Portion

Note: Base portion is replaceable without disassembly of Handle portion, Blade case portion and Motor portion.

Remove Switch box and Strain Relief which holds Power supply cord to Base complete.

Remove Plate from Base complete by unscrewing two M6x16 Pan head screws. They are accessible from Handle side.

Remove two 4x18 Tapping screws at the center of Slide cover.

Remove four M6x25 Pan head screws for securing Base complete and Table complete.

Lift up Base complete very carefully because a part of Base complete shown in **Fig.8** is apt to catch on the others.

Fig.8

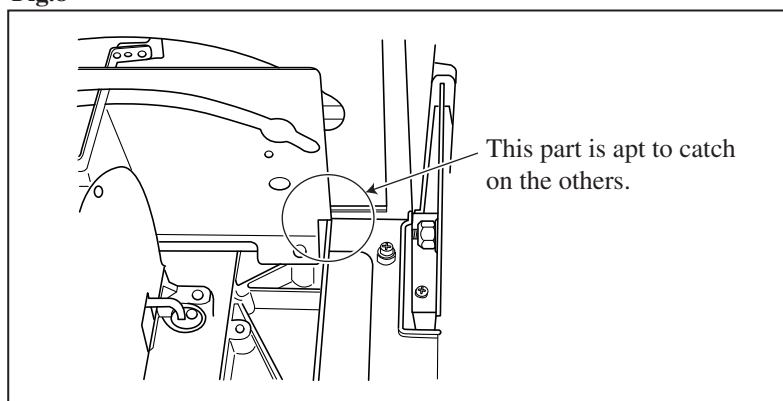

[7] Disassembling Bevel Cut Adjustment Portion and Depth Adjustment Portion

Refer to **Fig.8**.

Remove Handle 100 for Bevel cut adjustment and Knob 32 for depth adjustment.

Remove Spring pin 4-20 in Straight bevel gear using 1R308 as described in **Fig.9**, and then pull out Handle Shaft.

Note: If Handle shaft can not be pulled out due to burrs around spring pin hole, grind the spring pin hole to remove the burrs using a file.

Separate Stay from Handle shaft so that Plane bearing 12 can be removed. The stay is used to retain the Plane bearing 12.

Caution when assembling Bevel Cut Adjustment Portion and Depth Adjustment Portion

Install Plate and Base front cover in place before assembling the above portions.

When fixing Rack plate to Plate;

- 1) Insert Handle 100 for bevel cut adjustment.
- 2) Secure the Rack plate in the proper position on the Plate using two M5x12 Pan head screws so that the given play between two gears can be held at 90° vertical cut setting and 45° bevel cut setting. See **Fig.10**.

When fixing Plate to the reverse of Table;

- 1) Secure Lever 120 at 90° vertical cut angle.
- 2) Fasten one M6x16 Pan head screw ① as shown in **Fig.11**.
- 3) After unlocking the Lever 120, lock up Lever 120 again at 45° bevel cut angle.
- 4) Fasten another M6x16 Pan head screw ②.

Fig.10

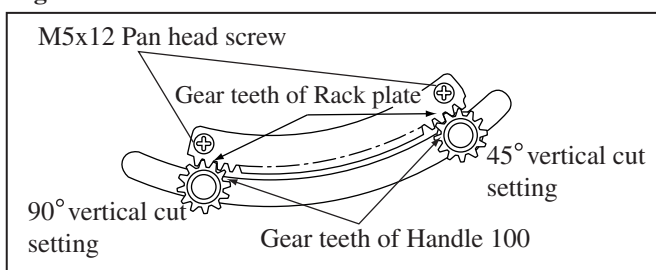

Fig.8

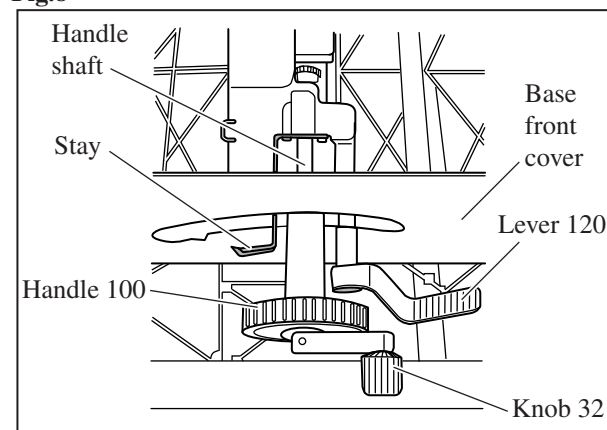

Fig.9

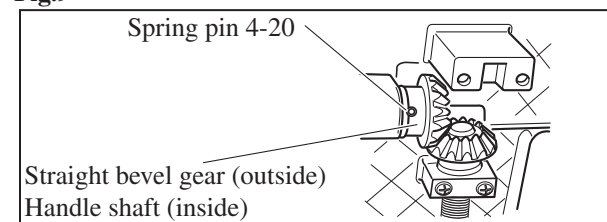
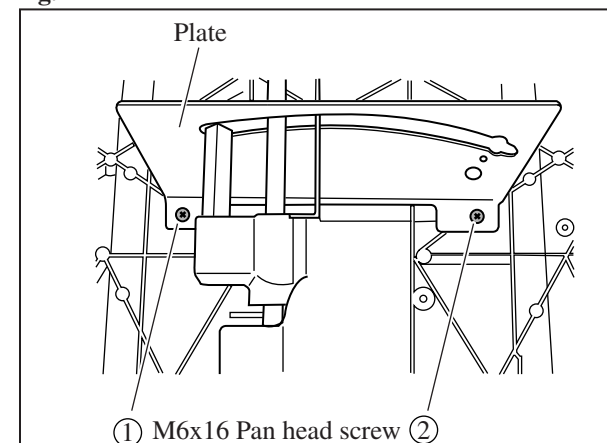

Fig.11



► Repair

[8] Disassembling Frame

Remove Gear housing portion. Refer to the clause [4] of page 2.

Remove Handle 100 for Bevel cut adjustment and Knob 32 for depth adjustment. Refer to the clause [7] of page 4. An example appears in **Fig.12**.

Remove four M6x20 Pan head screws from Frame retainer to separate Frame from Table.

Note: Do not loosen two M6x20 Hex bolts for adjust block at this time. If happening to loose them, parallel adjustment between Saw blade and Frame must be required.

Fig. 12

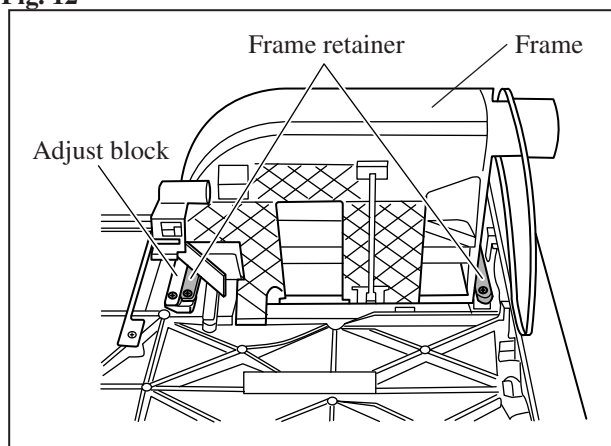

[8] Disassembling Sub Table

Remove Rail stopper at the reverse side of the right end on Front outer rail complete. Sub table with Front inner rail and Rear inner rail can be pulled out toward the right direction.

Sub table has a notch for holding by hand. When separating Front inner rail and Rear inner rail from Front outer rail complete and Rear outer rail complete, reassemble them so that the notch of Sub table faces outside.

[9] Clamping Adjustment to Sub Table

Push Sub table into the nearest position of Table complete to retract Front and Rear inner rails to their outer rails.

Refer to **Fig.13**. Adjust the clamping force to Sub table by screwing/unscrewing each M5x20 Hex. socket head bolts each (two pieces in total) using T-type hex. wrench 4-77 so that the Sub table can not move easily while clamping it with two Grips. The one of M5x20 Hex. socket head bolts is accessible from the hole in Front inner rail, the other is accessible from the hole in Rear inner rail.

Adjust the fastening force of M10 hex. socket head bolt and M10-17 Hex. lock nut so that the hinges of two Handle plates can be operated without backlash.

Fig. 12

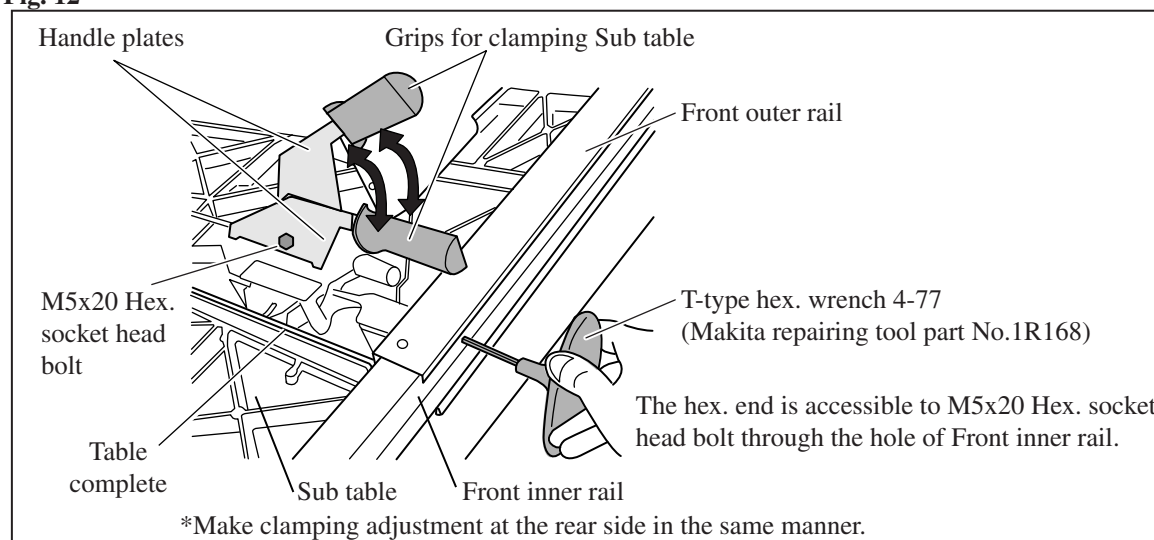

[10] Adjustment of Riving Knife

Only for American specifications: Adjust the fastening force of M6x16 Hex. bolt in order to remove the Riving knife smoothly by hand without backlash.

For all specifications: Adjust the Knife holder position to align the direction of Riving knife with Saw blade.

► Repair

[11] Adjustment of Ruler Ass'y

Parallel Adjusting Ruler Ass'y to Table

Loosen two M6x20 Hex. socket head screws out of three pieces on Ruler ass'y, pretighten the remaining screw located in the front side. See **Fig.13**.

Push the part designated by **↑** to stabilize the Ruler ass'y, and then fasten the two screws while aligning the Ruler ass'y with a groove on Table.

Fig. 13

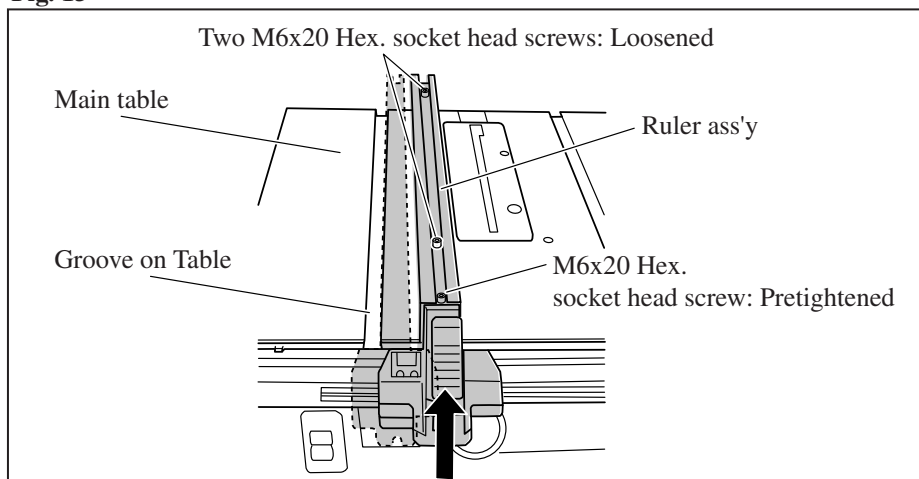

Adjusting Clamp Action of Ruler ass'y

Secure Sub table so as not to move by two Grips.

As illustrated in **Fig.14**, free a lever of the Ruler ass'y. And then fasten M5x655 Pan head screw to the limit using Phillips screwdriver.

Next, loosen the M5x15 Pan head screw until the Ruler ass'y can slide smoothly on two rails without backlash.

Finally, fasten M5x25 Pan head screw so that the opposite end of the Ruler ass'y can not moved while clamping the main table by the Ruler ass'y.

Fig. 14

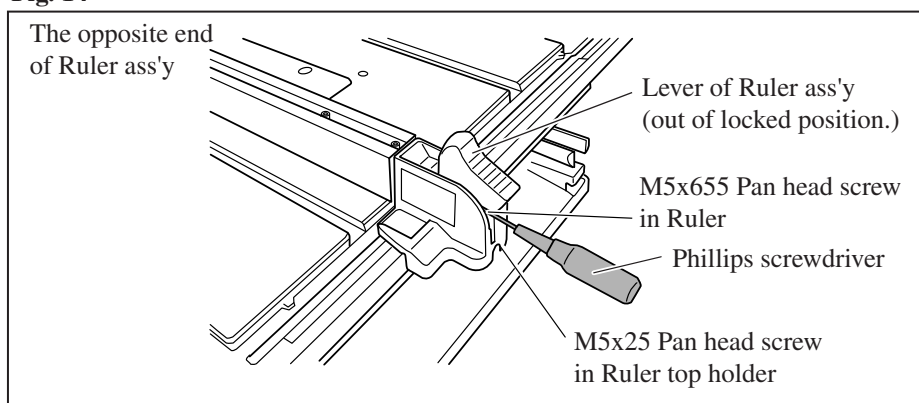

[12] Parallel Adjusting Saw Blade

Align one of the grooves on Table with Ruler ass'y.

Slide the Ruler ass'y along with Saw blade.

Loosen the securing force of Adjust block in front of Frame, and then move Saw blade to either right or left side to align it with the Ruler ass'y.

Adjust block is accessible from the clearance around levers in Base front cover by inserting a wrench 10 without upside down of the machine.

Frame can be moved while tapping the area designated by **↑** with Flat screwdriver as illustrated in **Fig.15**.

Fig. 15

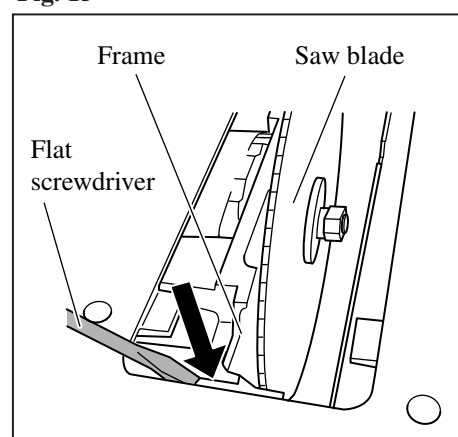

► **Repair**

Set the saw blade angle at 90° to Table using Makita repairing tool 90 degrees set square (Part No. 1R208) and M5x18 Pan head screw as illustrated in **Fig.16**. When setting the saw blade angle at 45° to table, use Makita repairing tool 45 degrees set square (Part No. 1R207) and another M5x18 Pan head screw as illustrated in **Fig.17**.

Fig. 16

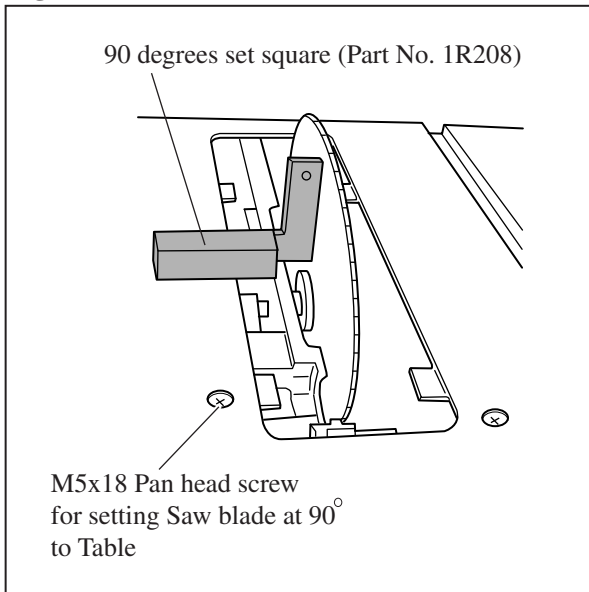
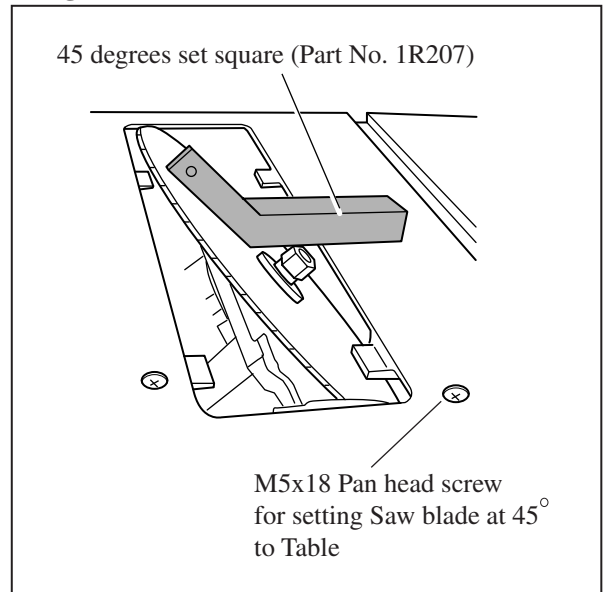
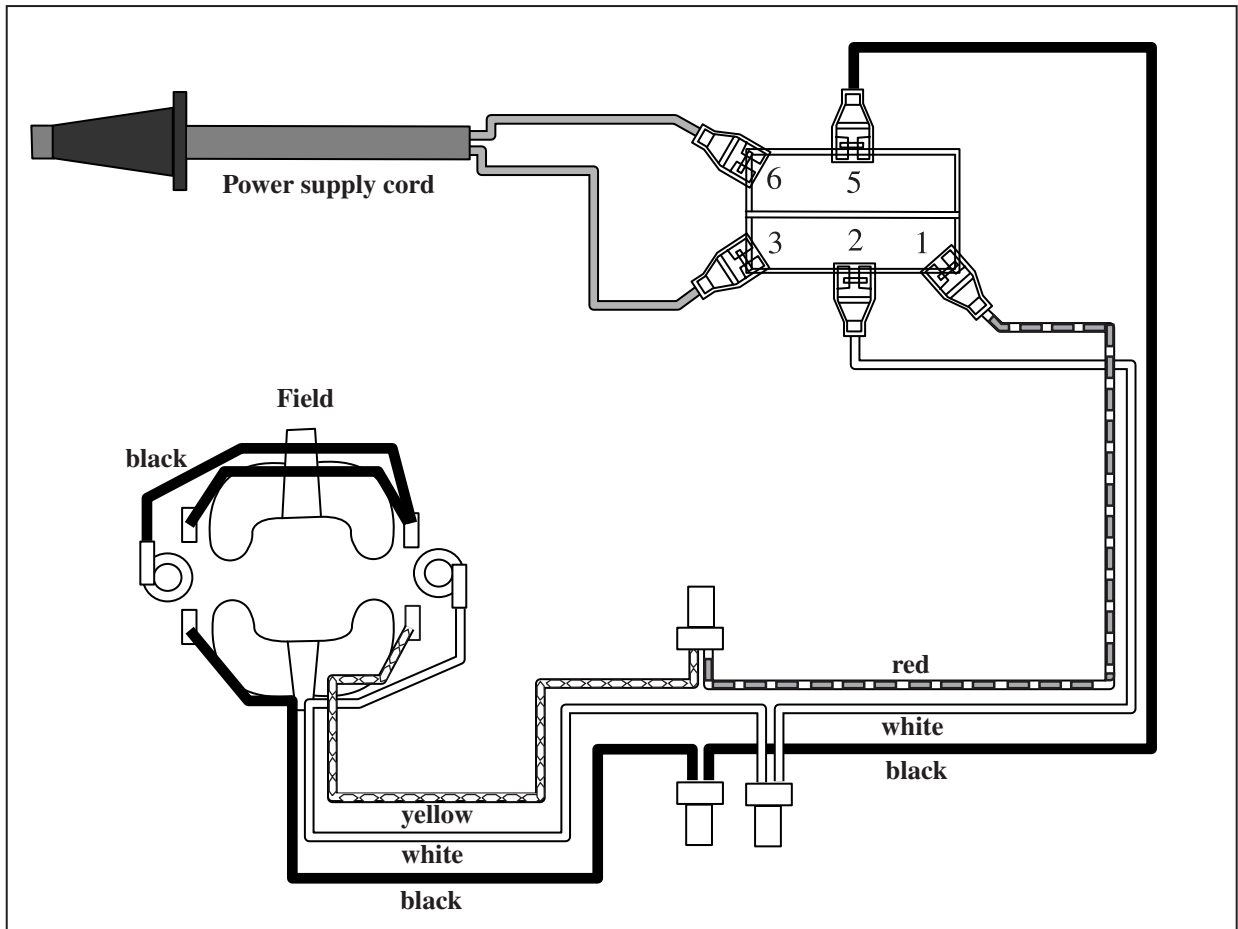

Fig. 17



► **Circuit diagram**

Canada, USA, Brazil 110V, Mexico



► **Circuit diagram**
 Europe(220V-240V), Turkey, South Africa

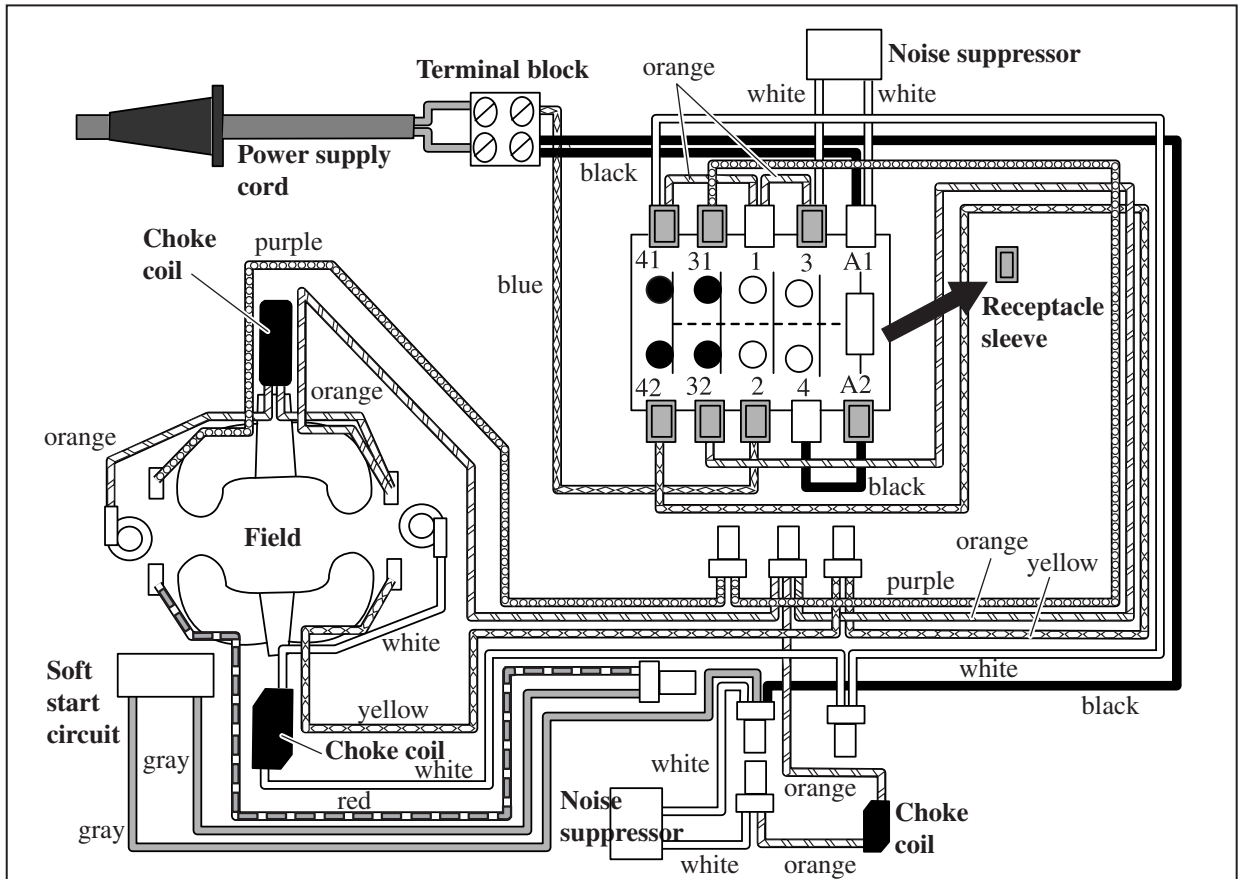

UK(110V)

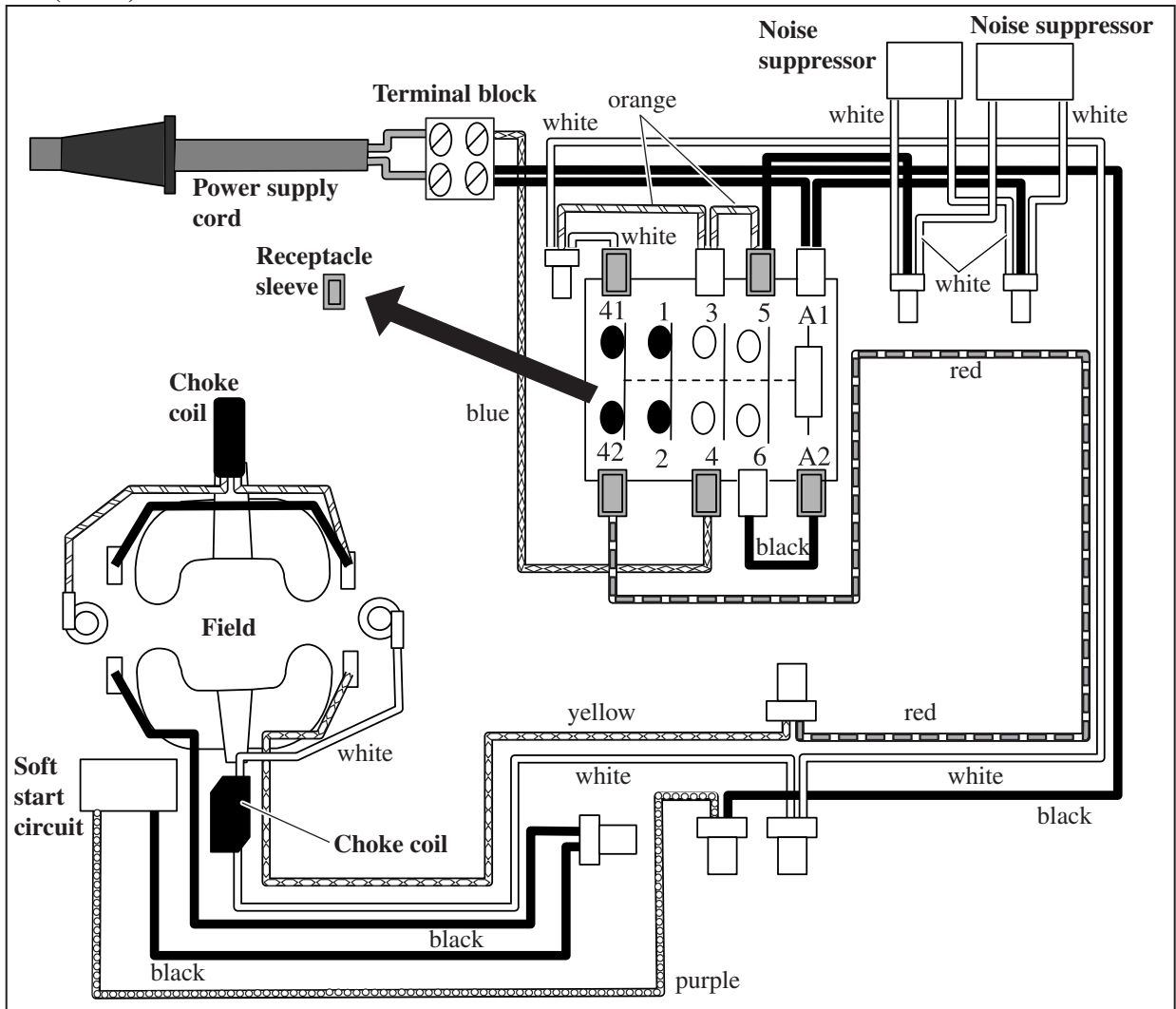

► **Circuit diagram**

Australia, New Zealand

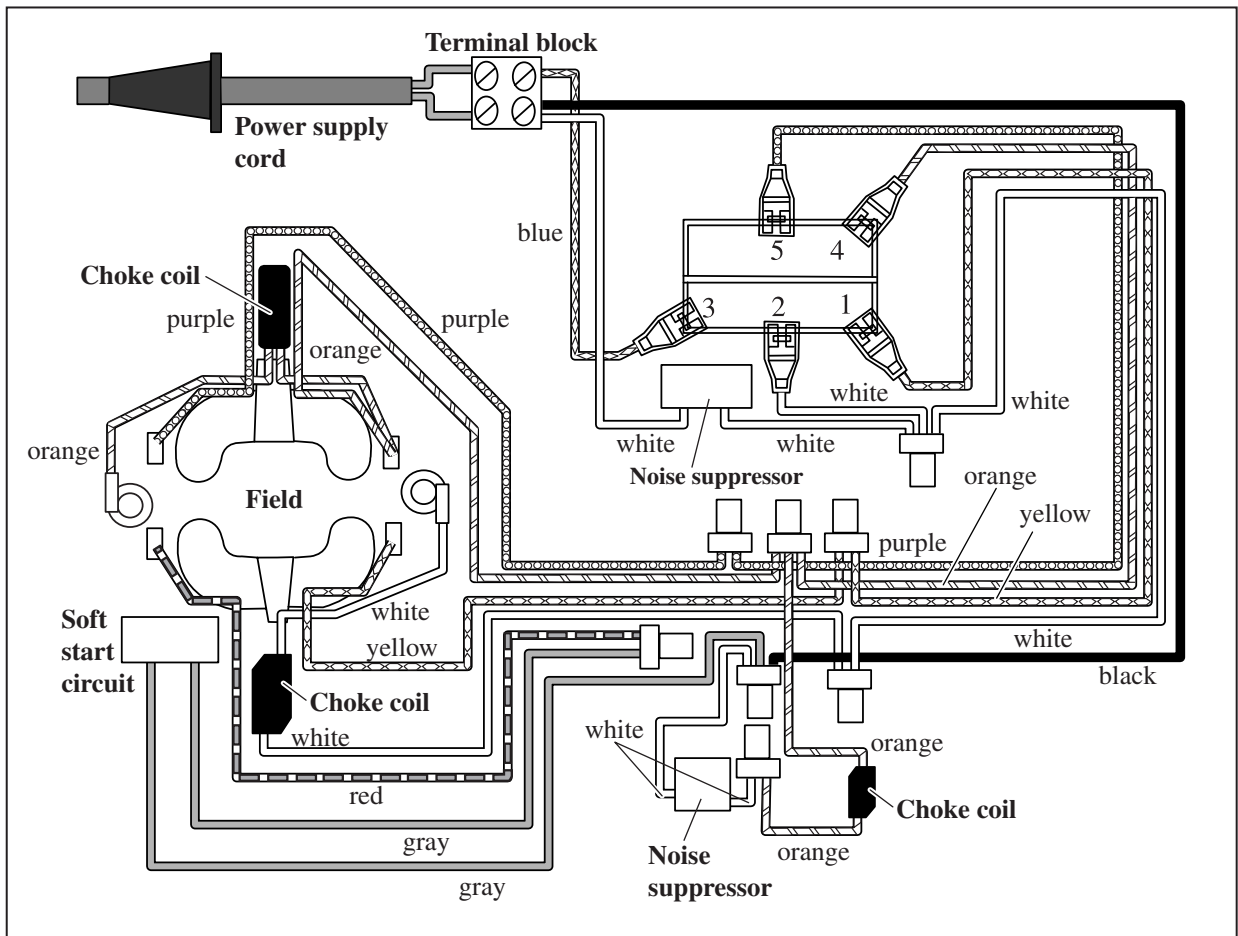

220V-240V Specifications Except Europe, Turkey, South Africa, Australia and New Zealand

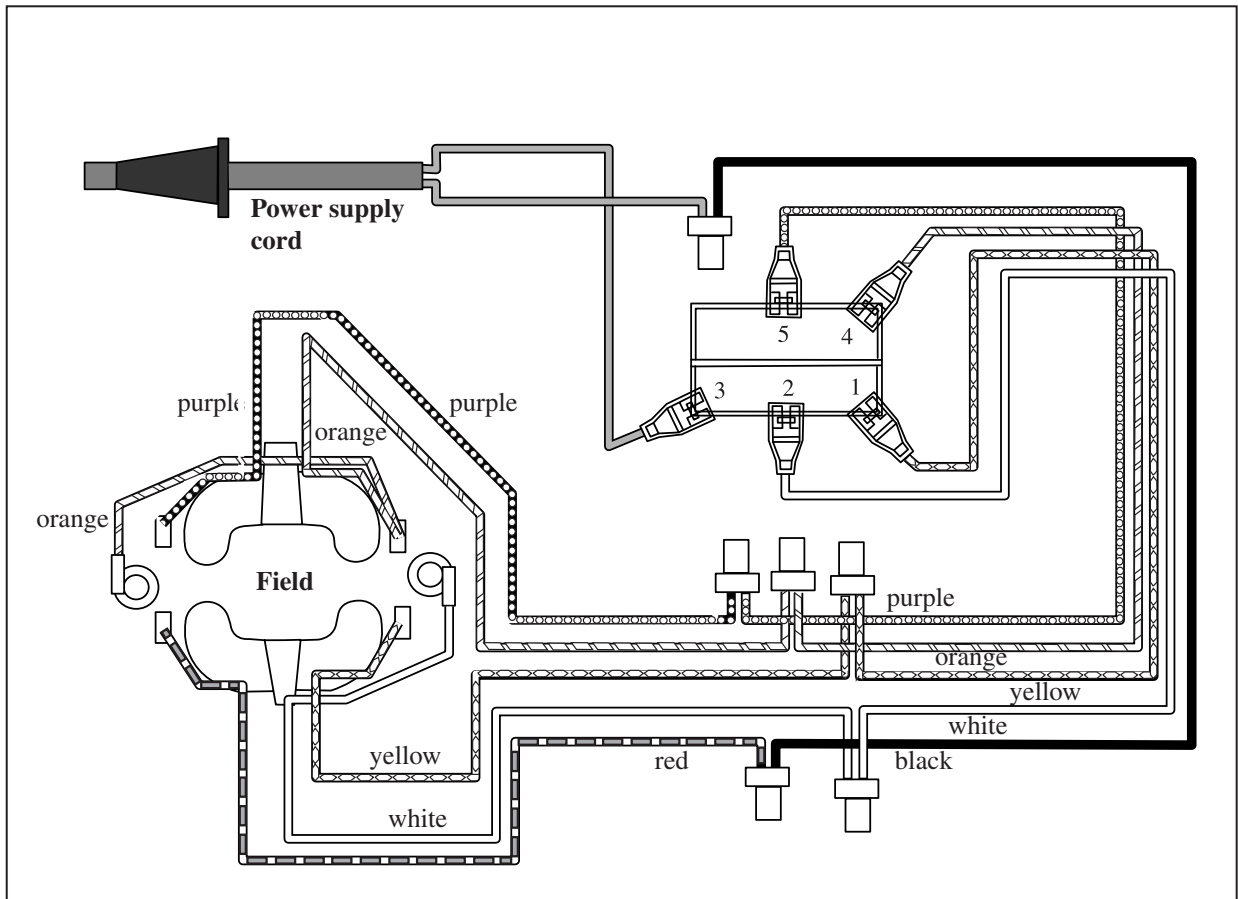

► Wiring

Put lead wires (and Noise suppressor and Choke coil if they are used) into place as illustrated below.

Canada, USA, Brazil(110V), Mexico

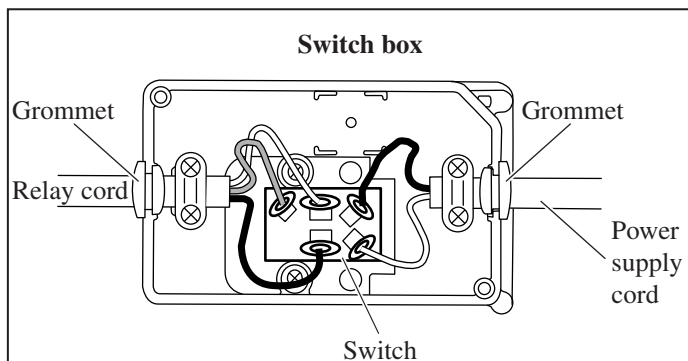
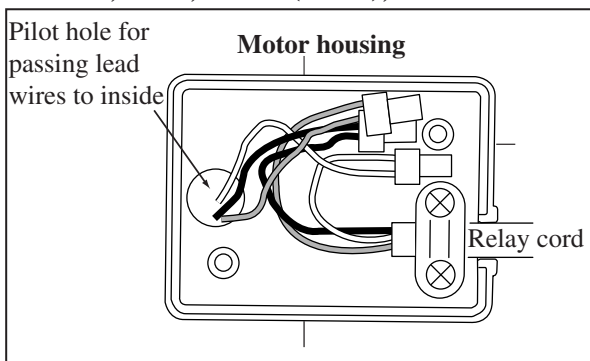

Europe, Turkey, South Africa

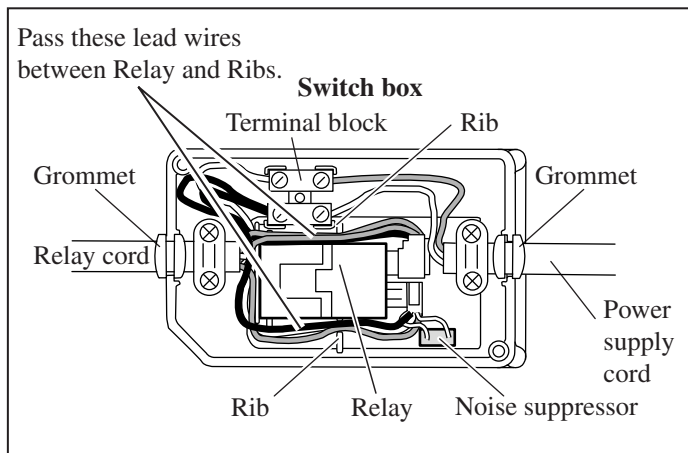
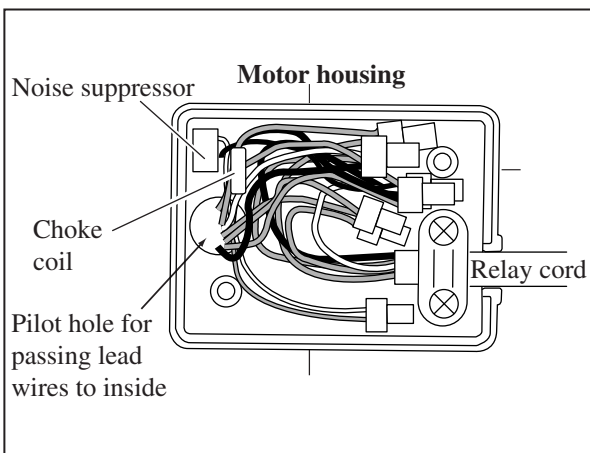

UK(110V)

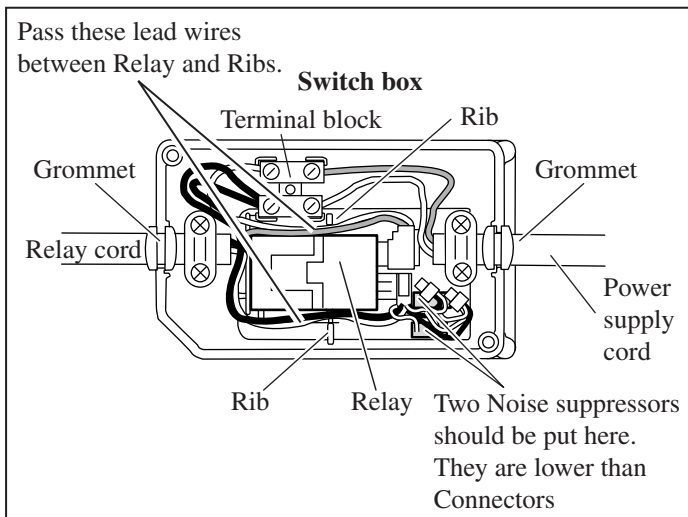
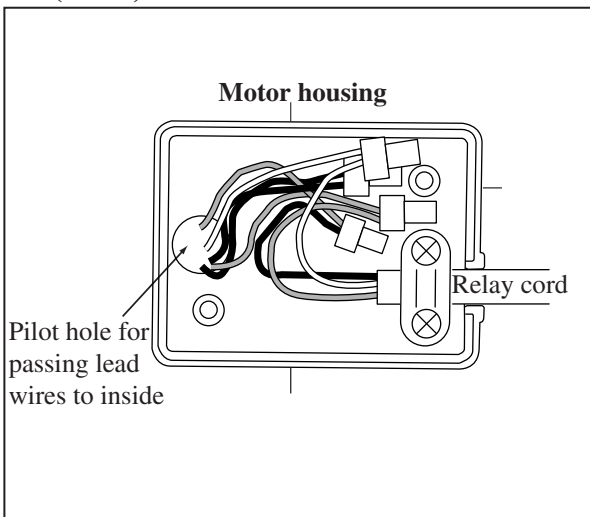

Australia, New Zealand

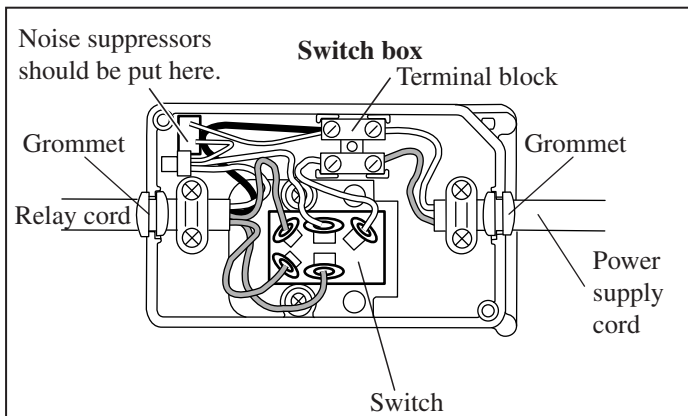
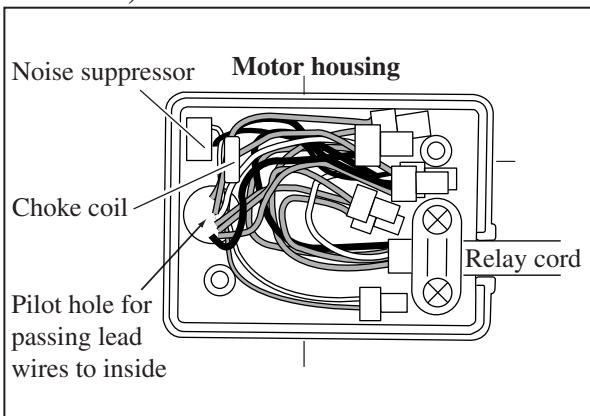

▶ Wiring

Put lead wires (and Noise suppressor and Choke coil if they are used) into place as illustrated below.

220V-240V Specifications Except Europe, Turkey, South Africa, Australia and New Zealand

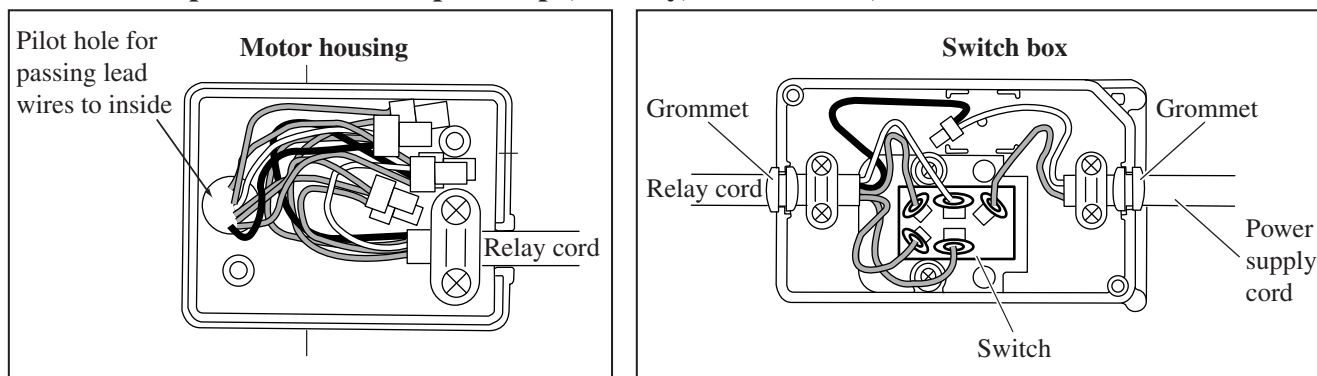

Caution on Power supply cord and Relay cord in Base complete

Do not make a slack between Switch box and Strain relief A.
 Fix Relay cord with Strain relief B in the prescribed position.
 See illustration below.

