

T ECHNICAL INFORMATION



New Tool

Models No. ▶ 3612

Description ▶ Router

CONCEPTION AND MAIN APPLICATIONS

Model 3612 is identical with the existing Model 3612C but has no electronic control.

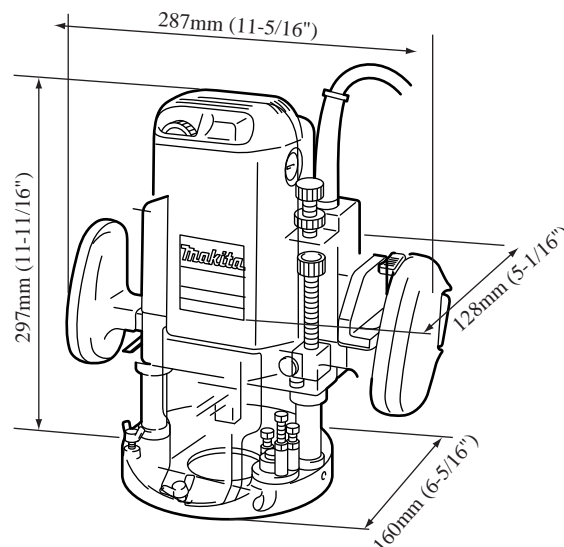

► Specifications

Voltage (V)	Current (A)	Cycle (Hz)	Continuous Rating (W)		Max. Output(W)
			Input	Output	
100	15.0	50/60	1,430	1,130	1,950
115	15.0	50/60	1,650	1,130	1,950
200	8.6	50/60	1,650	1,130	1,950
220	7.9	50/60	1,650	1,130	1,950
230	7.5	50/60	1,650	1,130	1,950
240	7.2	50/60	1,650	1,130	1,950

Collet Capacity	12mm or 1/2"
No Load Speed	22,000 R/min.
Plunge Capacity	0 - 60 mm (0 - 2-3/8")
Base Dia meter	160 mm (6-5/16")
Net weight	5.8 kg (12.8 lbs)

► Standard equipment

Straight Guide, Guide Holder Assembly, Collet Sleeve 6mm or 1/4", Collet Sleeve 8mm or 3/8", Wrench 24, Wrench 8, Straight Bit 12, Templet Guide 16

► Optional accessories

Various types of Router Bits, Various sizes of Templet Guides, Collet Sleeve 6 mm, 8 mm, 10 mm, 1/4", 3/8", Guide Holder Assembly, Straight Guide, Trimmer Guide, Vacuum Head, Templet Guide Adapter, Lock Nut, Router Stand

The standard equipment for the tools shown may differ from country to country