

**Models No.** ▶ 3700D

**Description** ▶ MAKITA Cordless trimmer

## CONCEPTION AND MAIN APPLICATIONS

The light weighing and compact model Cordless trimmer has been developed for various applications such as drilling process for the wall board and ceiling board, spot facing for the hinge and chamfering process for fittings.

The helical cutter bit is the exclusive one.

There is no similar model in other companies.

The 3700DW is made through the combination of the following units :

3700D(MAKITA Cordless trimmer)

DC7000(MAKITA Fast charger)

Battery 7000

(Note) The 3700D is the the model without Battery and Charger.

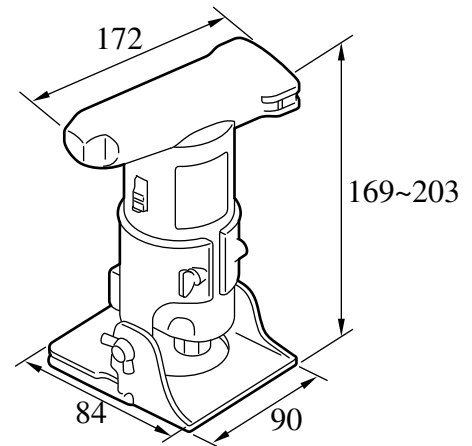

### ▶ Specifications

<b>Moter</b>	DC 7.2 V magnet motor
<b>No load speed</b>	8000/min
<b>Chuck hole diameter</b>	6mm(6.35mm for certain countries)
<b>Weight(kg)</b>	1.0 kg (without battery)

### ▶ Standard equipment

Straight bit 6(High speed steel helical cutter)---One piece

Guide base assembly --- One piece

Spanner 10--- One piece

Spanner 17---One piece

### ▶ Optional accessories

Template guide

Straight guide assembly

Trimmer guide assembly

Circle cut base assembly

Straight bit 6

Battery 7000

## ► **Repair**

### 1. Assembling of the housing

Assemble the parts other than battery on the housing L, slide the switch lever to the ON side, and then assemble the housing R.(If the switch lever is at OFF side, you cannot correctly assemble the housing.)

### 2. Operation of the switch lever

After the housing has been assembled, repeat loading/unloading of the battery and controlling of the switch lever several times to check if the switch safety function can correctly activate.