

# T ECHNICAL INFORMATION



New Tool

**Models No.** ▶ 3703

**Description** ▶ 6 mm (1/4") Trimmer

## CONCEPTION AND MAIN APPLICATIONS

Cutting depth can be adjusted smoothly and precisely with a rack and pinion type of fine depth adjustment. Model 3704 with an angle-adjustable base can perform chamfering with a straight bit. (Note: Model 3703 has a conventional base.)

< Model 3703 >

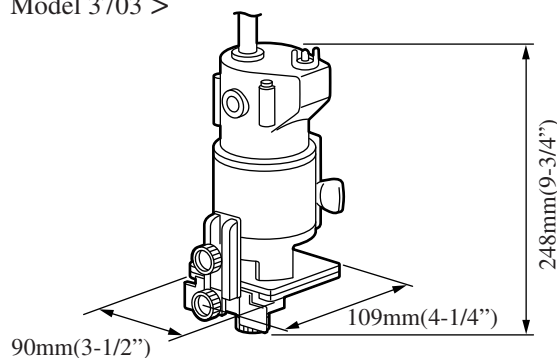

< Model 3704 >

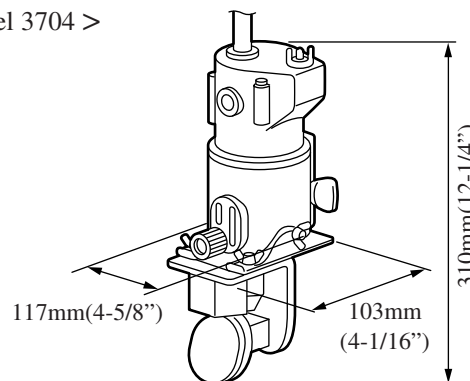

### ▶ Specifications

Voltage (V)	Current (A)	Cycle (Hz)	Continuous Rating (W)		Max. Output(W)
			Input	Output	
100	3.8	50-60	350	230	310
115	3.3	50-60	350	230	310
200	1.9	50-60	350	230	310
220	1.7	50-60	350	230	310
230	1.7	50-60	350	230	310
240	1.6	50-60	350	230	310

<b>No Load Speed</b>	30,000 R/min.
<b>Net Weight</b>	1.5 kg (3.3 lbs)
<b>Collet Chuck Capacity</b>	6 mm or 1/4"
<b>Base Slide Range</b>	0 - 40 mm (0 - 1-9/16")

### ▶ Standard Equipment

Straight guide, Wrench 10, 17, Templet guide 10, Straight bit 6, Trimmer guide (for Model 3704 only)

### ▶ Optional Accessories

Various kinds of trimmer bits with 6 mm or 1/4" shank, Sash router base, Trimmer base assembly, Trimmer shoe

## ► **Repair**

- i) To assemble the armature on the motor housing, be sure to place the wave washer 23 on the bottom of the bearing box.
- ii) Use care that the lead wire may not cause pitching when mounting the rear cover.