

TECHNICAL INFORMATION



PRODUCT

P 1 / 3

Model No. ▶ 3707FC, 3708FC

Description ▶ Trimmers

CONCEPT AND MAIN APPLICATIONS

The above models have slimmer bodies for easy to grip, comparing with the existing model 3703 and 3704.

Their further features are :

- 3707FC : * Adjusting roller for fine-adjustment of cutting depth precisely.
 * LED Job Light is installed for lighting up at working point.
 * Electronic features for speed control for keeping constant speed under the loaded condition and soft start for suppressing starting shock.

3708FC : Equipped with adjustable trimmer base angle for obtaining desired cutting angle, in addition to the features of 3707FC,

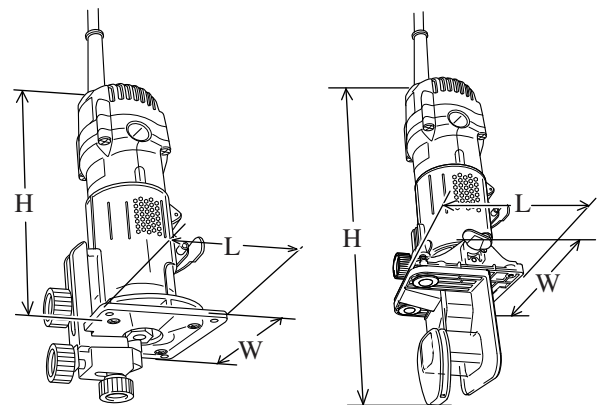

3707FC

3708FC

Dimensions : mm (")		
Model No.	3707FC	3708FC
Length (L)	90 (3-1/2)	103 (4-1/16)
Height (H)	204 (8)	308 (12-1/2)
Width (W)	90 (3-1/2)	117 (4-13/16)

Specification

Voltage (V)	Current (A)	Cycle (Hz)	Continuous Rating (W)		Max. Output(W)
			Input	Output	
110	4.8	50/60	500	150	500
120	4.4	50/60	500	150	500
230	2.3	50/60	500	150	500

Model No.)	3707FC	3708FC
No load speed: (min -max rpm)	26,000	26,000
Collet capacity	6 mm or 6.35 mm (1/4")	6 mm or 6.35 mm (1/4")
Stroke of trimmer head: mm (")	35 (1-3/8)	35 (1-3/8)
Adjustment of trimmer base angle		0° - 45°
LED Job Light	Yes	Yes
Electronic features for	Soft starter	Yes
	Speed control	Yes
Protection from electric shock	by double insulation	by double insulation
Net weight: Kg (lbs)	1.2 (2.6)	1.3 (2.9)
Cord length: m (ft)	2.5 (8.2)	2.5 (8.2)

Standard equipment

- * Trimmer guide assembly 1 pc.
- * Straight guide 1 pc.
- * Templet guide 1 pc.
- * Wrench 10 1 pc.
- * Wrench 17 1 pc.
- * T.C.T. Straight bit 1 pc.

< Note > The standard equipment for the tool shown may differ from country to country.

Optional accessories

- * Various router bits
- * Straight guide
- * Trimmer guide assembly
- * Trimmer shoe
- * Collet cone 6mm
- * Collet cone 1/4"
- * Templet guide
- * Trimmer base assembly
- * Flexible hose
- * Joint

► Repair

< Assembling armature of commutator side >

< Note in assembling >

1. Do not assemble the used self lock. The self lock has to be always replaced with the fresh one.
2. Pay attention to the assembling direction of self lock and wave washer 6. See Fig. 1
3. The magnet sleeve is installed to the armature shaft on commutator side for sensing the variation of rotating speed. If it would be damaged, the electronic speed control does not work any more.
So, applying 1R026 " Bearing setting pipe" to self lock, press it with your hand, instead of with arbor press.

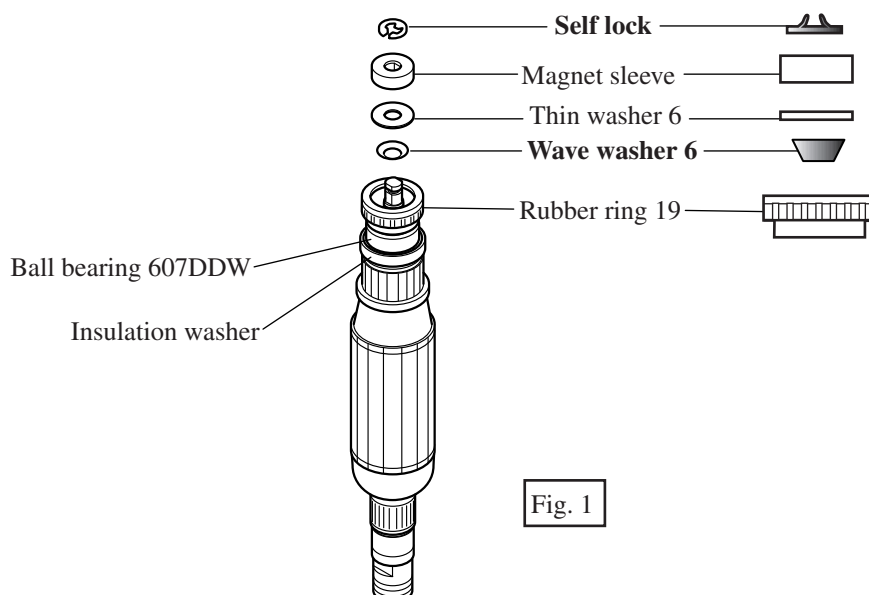
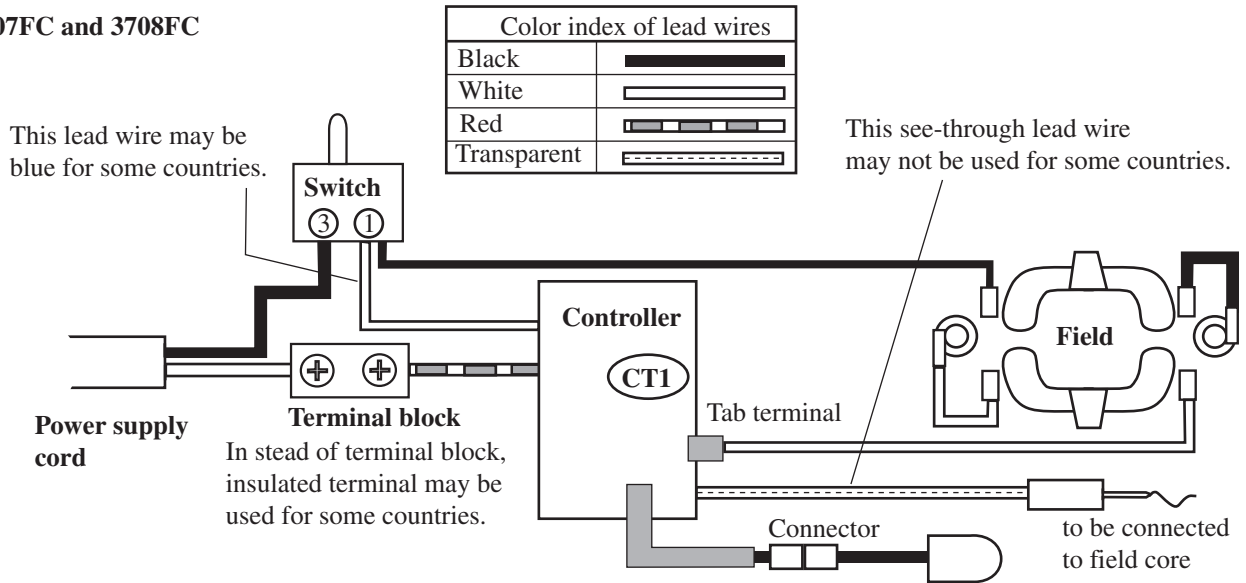

Fig. 1

► **Circuit diagram**

3707FC and 3708FC



► **Wiring diagram**

3707F and 3708F with LED Job light

