

# T ECHNICAL INFORMATION



**Models No.** ▶ 3901

**Description** ▶ Plate Joiner

## CONCEPTION AND MAIN APPLICATIONS

Model 3901 is designed for plate joining which creates strong joints (T-butt joint, corner joint, miter joint, frame joint, etc) in a minimum of time. It can also be used to trim paneling that has been installed on walls.

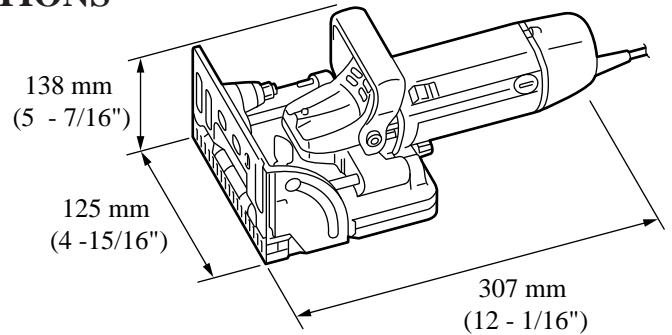

### ▶ Specifications

Voltage (V)	Current (A)	Cycle (Hz)	Continuous Rating (W)		Max. Output(W)
			Input	Output	
100	6.2	50/60	590	380	570
115	5.6	50/60	590	380	570
200	3.1	50/60	590	380	570
220	2.8	50/60	590	380	570
230	2.7	50/60	590	380	570
240	2.6	50/60	590	380	570

Cutter Blade Size (Outer Dia. x Edge Thickness x Arbor Dia.)	100 mm (4") x 4 mm (5/32") x 22 mm (7/8")	
Circular Saw Blade Size (Outer Dia. x Arbor Dia.)	110 mm (4-3/8") x 20 mm (3/4")	
Max. Cutting Depth	For Cutter Blade	20 mm (3/4")
	For Circular Saw Blade	25 mm (1")
No Load Speed	10,000 R/min.	
Net Weight	2.8 kg (6.2 lbs)	

### ▶ Standard equipment

Angle Guide, Dust Bag, Lock Nut Wrench 20, Steel Carrying Case

### ▶ Optional accessories

Combination Saw Blade 110-1, Cross-cut Saw Blade 110-2, Carbide-tipped Saw Blade 110-11, Cutter Blade 100-4