

T ECHNICAL INFORMATION



New Tool

Models No. ▶ 4101R

Description ▶ 110 mm (4-3/8") Cutter

CONCEPTION AND MAIN APPLICATIONS

Model 4101R is basically the same as Model 4100R except that Model 4101R can accept up to 125 mm (5") diamond wheel and can perform bevel cutting.

This tool is ideal for cutting in masonry, concrete, tile, etc.

(Note)

This tool does not come with diamond wheel.

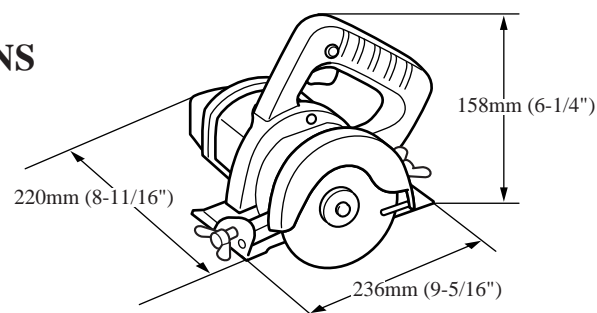

▶ Specifications

Voltage (V)	Current (A)	Cycle (Hz)	Continuous Rating (W)		Max. Output(W)
			Input	Output	
100	12.0	50-60	1,100	650	800
115	7.5	50-60	860	500	800
200	4.5	50-60	860	500	800
220	4.0	50-60	860	500	800
230	4.0	50-60	860	500	800
240	3.8	50-60	860	500	800

No Load Speed		11,000 R/min.
Arbor Hole Dia.		20 mm (3/4")
Max. Cutting Depth	with a 110 mm (4-3/8") diamond wheel	34 mm (1-5/16") at 90° 21 mm (13/16") at 45°
	with a 125 mm (5") Diamond wheel	41.5 mm (1-5/8") at 90° 26 mm (1") at 45°
Bevel Cutting Angle		0 - 45°
Net Weight		3.0 kg (6.6 lbs)

▶ Standard equipment

Wrench 22, Socket wrench 9, Water-feed device (water plug and tube)

▶ Optional accessories

Diamond wheel 110 (dry type and wet type), Abrasive cut-off wheel 110 (No. 12 and No.14), Rip fence (Guide rule), Wing bolt M5x10 (for securing the rip fence)