

# T ECHNICAL INFORMATION



**Models No.** ▶ 4105KB

**Description** ▶ MAKITA No.5-model Dust proof cutter

## CONCEPTION AND MAIN APPLICATIONS

This machine is upgraded by one rank than 4103KB to cope with the various applications, wherein not only that the cutting capacity is extremely enhanced, but it also can be applied for the block and tile, which could not have been cut by the conventional model 4103KB.

The dust proof capacity has been improved than ever as well.

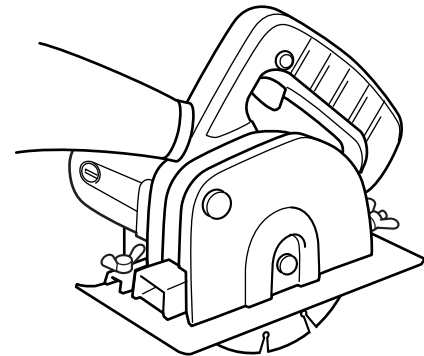

### ▶ Specifications

<b>Voltage (V)</b>	<b>Current (A)</b>	<b>Cycle (HZ)</b>
Single-phase 100V	11.0	50/60

<b>No load speed</b>	7500 R.P.M./min.
<b>Capacity</b>	40.5 mm(Max. cutting depth)
<b>Net Weight</b>	3.0 kg
<b>Continuous rating input</b>	1050 W
<b>Power supply cord</b>	2.5 m

### ▶ Standard equipment

- Spanner 22--- One piece
- Box wrench 9--- One piece

### ▶ Optional accessories

- Diamond wheel 125mm
- Guide ruler--- One piece
- Thumb bolt M5x10--- One piece(For mounting the parallel ruler)

## ► **Repair**

Conform to the same procedures as the ones for the #4103KB.

To assemble/disassemble the separate, use care not to bend the tool.

For replacing the separate for repair, when the motor rotation is heavy or locked, slightly loosen the screw for holding the motor case to increase the motor rotation, make trial running, and once the rotation has been made light, fasten the screws little by little.

Tool used

+ screw driver, Spanner 22, Box wrench 9, Circle clip plyer