

TECHNICAL INFORMATION



PRODUCT

P 1 / 11

Models No. ▶ 4112H, 4112HS

Description ▶ 305mm (12") Angle Cutter

CONCEPTION AND MAIN APPLICATIONS

The above 305mm (12") angle cutters have been developed as a successor to the existing model 4110C.

Their features and benefits are ;

- * Super Joint System - SJS for suppression of shock and prevention of damage on gear.
- * 305mm (12") diamond wheel which provides max. cutting depth; 100mm (4"), can be used.

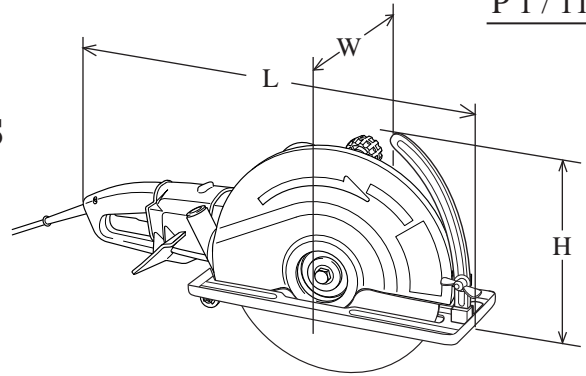

Dimensions : mm (")	
Length (L)	648 (25-1/2)
Width (W)	240 (9-1/2)
Height (H)	273 (10-3/4)

* Width (W):from the base to the rear of motor housing

► Specification

	Voltage (V)	Current (A)	Cycle (Hz)	Continuous Rating (W)		Max. Output(W)
				Input	Output	
4112H	120	15	AC / DC	1,650	800	3,000
4112HS	110	23	50 / 60	2,400	1,500	2,750
	120	15	50 / 60	1,650	800	3,000
	220	11.5	50 / 60	2,400	1,600	3,700
	230	11	50 / 60	2,400	1,600	3,700
	240	10.5	50 / 60	2,400	1,600	3,700

Model No.	4112H	4112HS
No load speed : min-1= rpm.	5,000	
Wheel size	Diameter : mm (")	305 (12)
	Arbor : mm (")	25.4 (1)
Safety clutch	Yes (Super Joint System)	
Soft start feature	No	Yes
Net weight : kg (lbs)	10.3 (22.7)	
Power supply cord :m (ft)	2.5 (8.2)	

► Standard equipment

- * Socket wrench 17 1 pc.
- * Plastic carrying case 1 pc.

< Note > The standard equipment for the tool shown may differ from country to country.

► Optional accessories

- * Various diamond wheels (dry only)
- * Various abrasive cut off wheels
- * Ring 20
- * Base set
- * Elbow joint 32 assembly
- * Plastic carrying case

< 1 > Lubrication

Apply MAKITA grease SG. No.0 to the following portions designated by black triangle to protect parts and product from unusual abrasion.

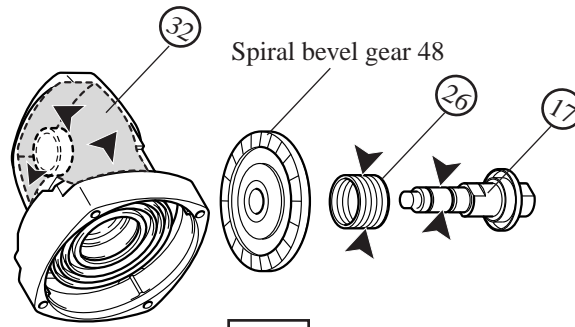

Fig. 1

Position No.	Parts items	The portion to be lubricated	Amount to be applied
17	Spindle	The portion where spiral bevel gear 48 contacts	approx. 1g (0.04 oz)
26	Lock spring 24	Its surface	approx. 1g (0.04 oz)
32	Gear housing	Its gear room	approx. 40g (1.41 oz)

< 2 > Removing base and wheel cover

(1) Remove wing bolt M8x20, spring washer 8, flat washer 8 and 2 pcs. of hex bolt M6. Then, base can be removed from the machine. See Fig. A.

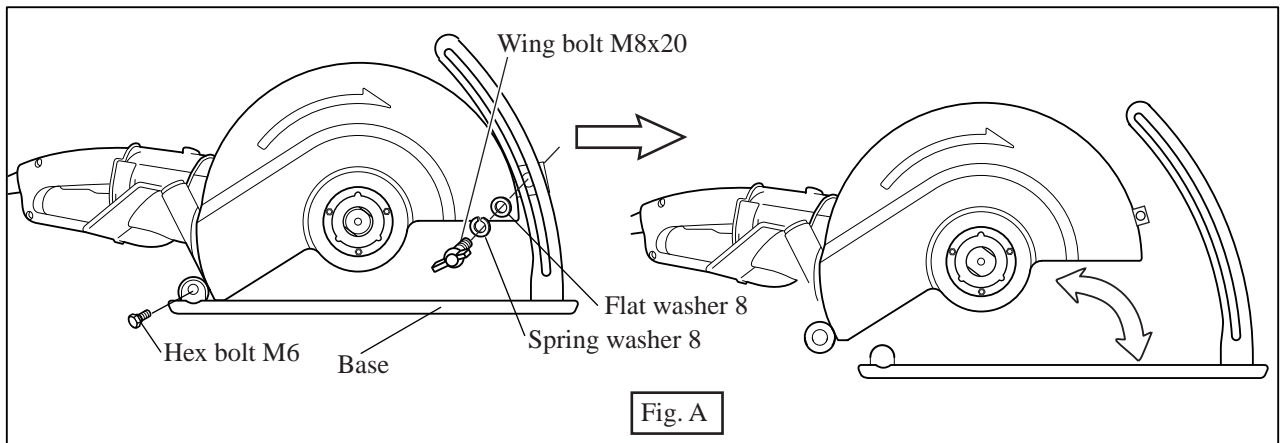

Fig. A

(2) Remove pressure plate by unscrewing 3 pcs. of hex bolt M5x14. Then, the wheel cover has been disengaged from bearing box. See Fig. B.

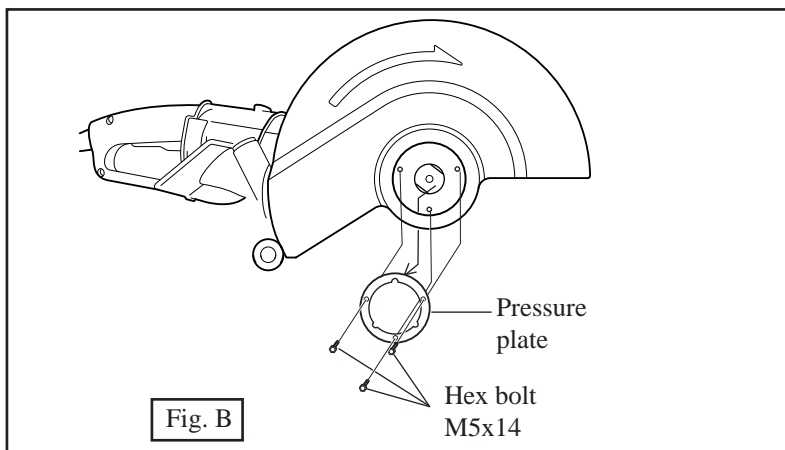
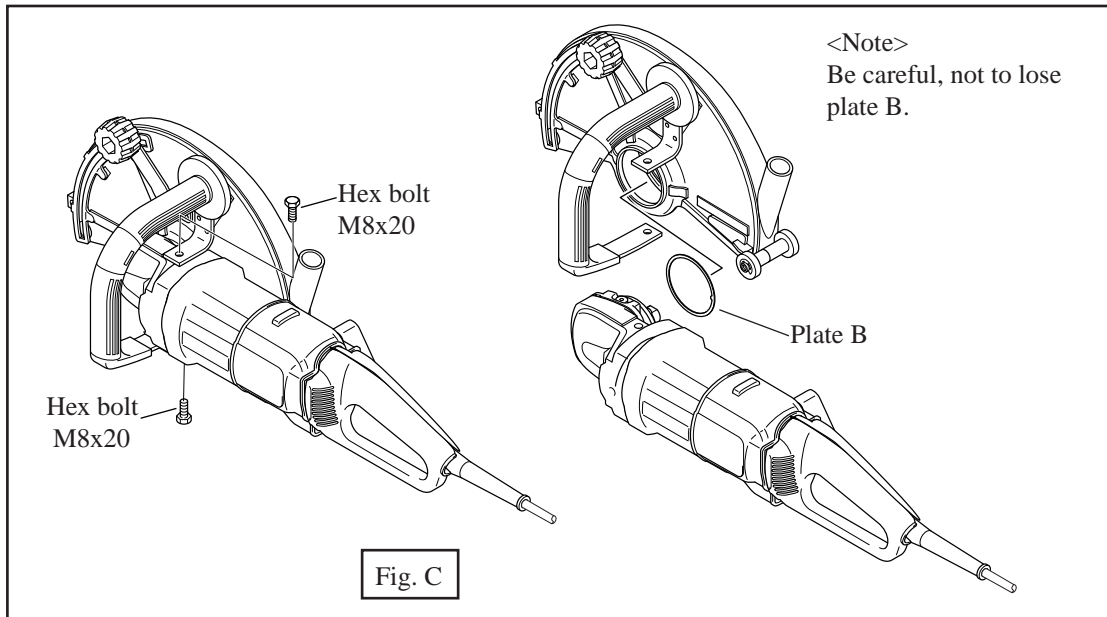

Fig. B

(3) Remove 2 pcs. of hex bolt M8x20. Then wheel cover section can be removed from the machine.
See Fig. C.



< 3 > Disassembling gear section

- (1) Remove gear section by unscrewing 4 pcs. of hex bolt M5x14. See Fig. 2.
- (2) Remove ball bearing 6000LLB. See Fig. 3.
- (3) After removing retaining ring S-15, remove flat washer 15. See Fig. 4.
- (4) Spiral bevel gear 48 with lock sleeve can be separated from spindle. See Fig. 5.
- (5) Remove spindle by pressing with arbor press as illustrated in Fig. 6.

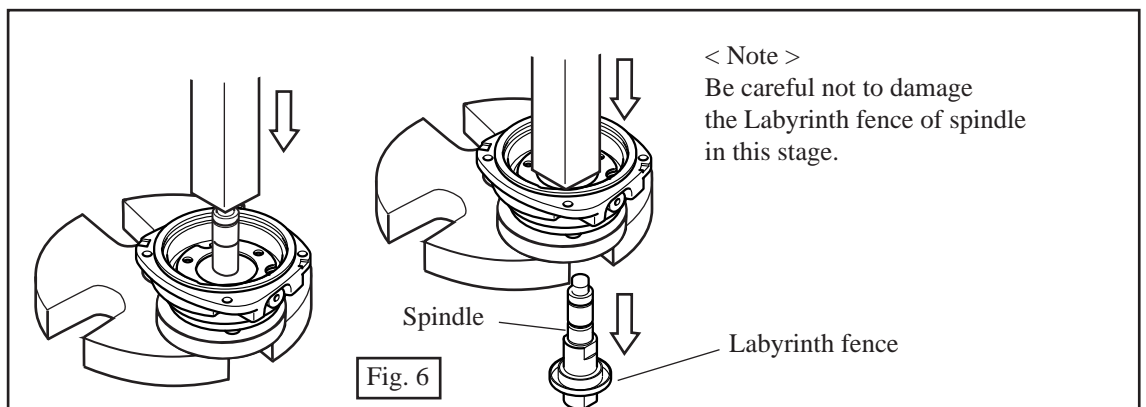
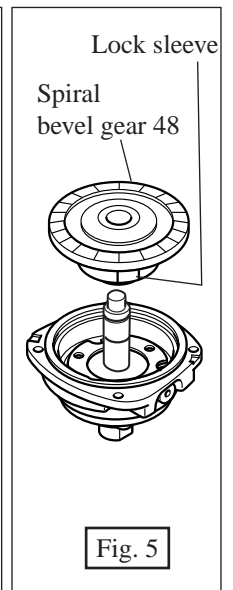
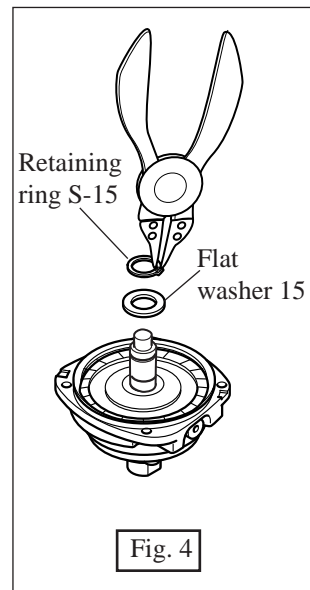
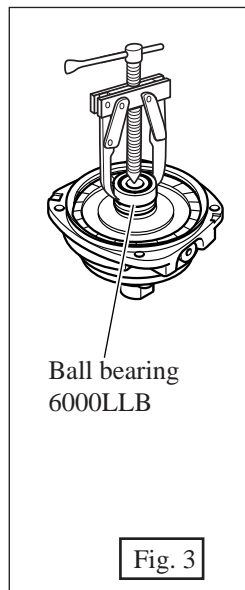
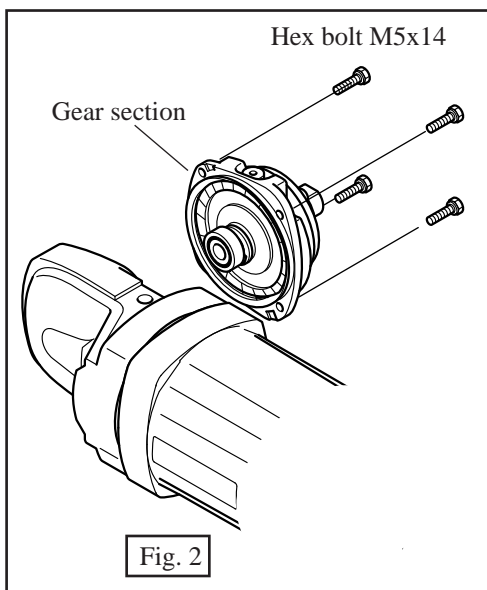

< 4 > Assembling gear section

- (1) Mount spindle by pressing with arbor press from wheel side. See Fig. 6.
- (2) Mount spiral bevel gear 48 together with lock sleeve. See Fig. 7.
- (3) Mount flat washer 15. Secure the spiral bevel gear 48 and the flat washer 15 with retaining ring S-15. See Fig. 8.
- (4) Mount flat washer 15. Secure the spiral bevel gear 48 and the flat washer 15 with retaining ring S-15. See Fig. 8.
- (5) Put ball bearing 6000LLB on the bearing setting plate. Mount the spindle which has been mounted to the bearing box, to the ball bearing 6000LLB by pressing with arbor press. See Fig. 9.
The assemble of gear section has been completed at this stage.
- (6) Mount the gear section to gear housing, and secure it with 4 pcs.of pan head screw M5x14. See Fig. 10.

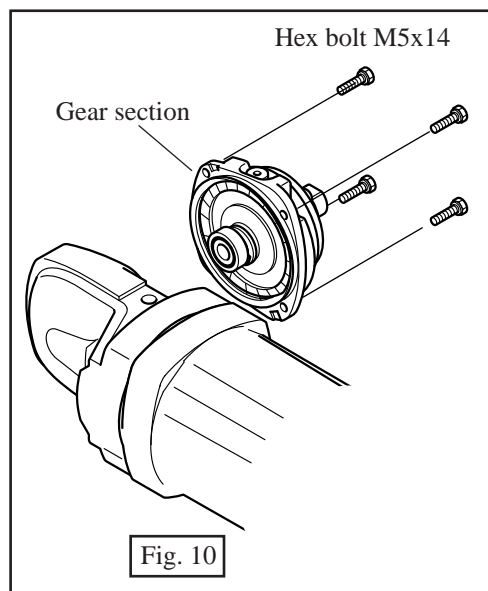
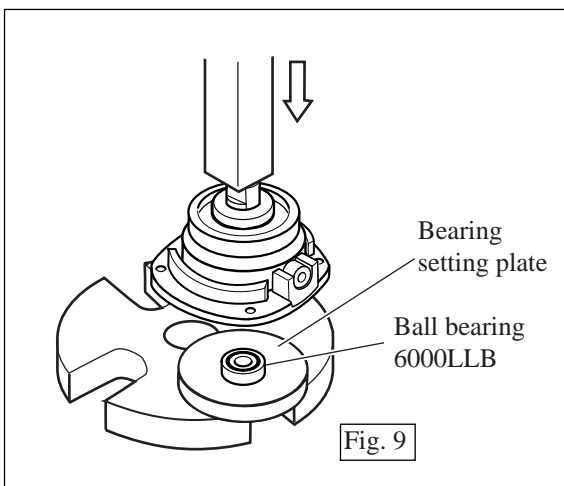
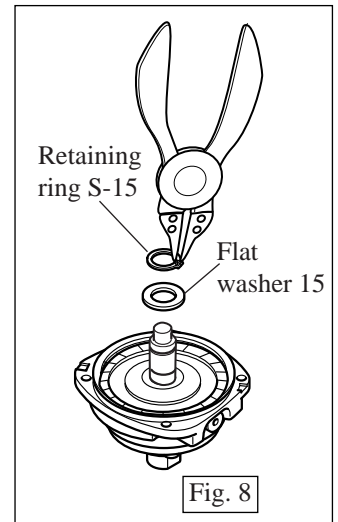
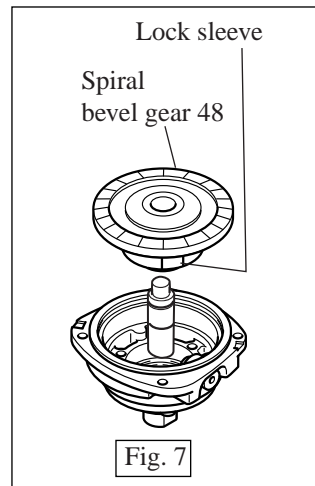
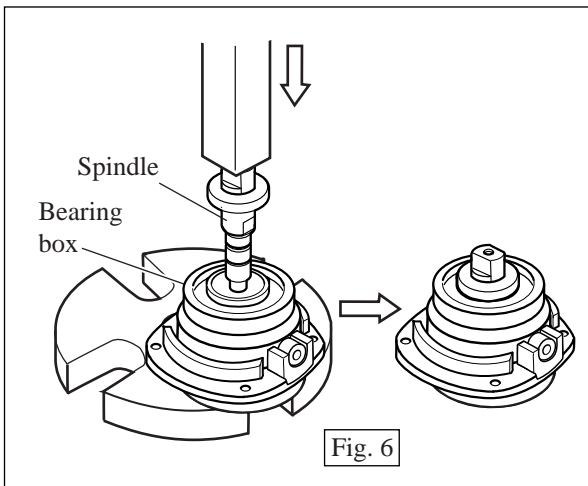

< 5 > Disassembling clutch section

- (1) For removing clutch section from bearing box, take the step of Fig. 2, Fig.3, Fig.4 and Fig. 5 at page 3.
- (2) Turning lock sleeve clockwise, pull the spiral bevel gear 48. So lock sleeve can be separated from the spiral bevel gear 48. See Fig. 11.
- (3) Turning the lock spring 24 clockwise, pull the spiral bevel gear 48. So lock spring 24 can be separated from the spiral bevel gear 48. See Fig. 12.

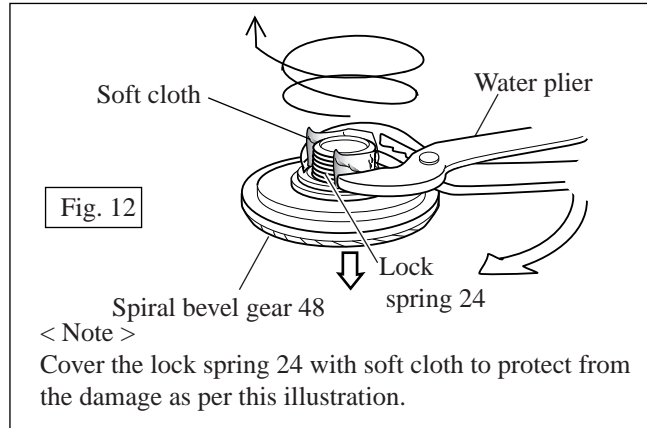
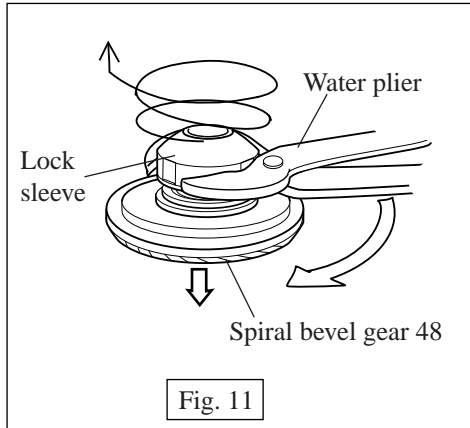

< 6 > Assembling clutch section

- (1) Apply MAKITA grease SG. No.0 to the lock spring 24.
- (2) First, put the lock spring 24 slantingly on the spiral bevel gear 48. And press, such as, the portion A of lock spring 24 See Fig. 13A
Second, turn the spiral bevel gear 48, and press the portion D. See Fig. 13B
Thirdly, turn the spiral bevel gear 48, and press the portion C. See Fig. 13C
Fourthly, turn the spiral bevel gear 48, and press the portion B. See Fig. 13D.
And finally, press the lock spring 24 into the spiral bevel gear 48 completely. See Fig. 13E.
- (3) Lock sleeve can be mounted to the spiral bevel gear 48 in the same way as the lock spring 24. See Fig. 14A,B,C and D.

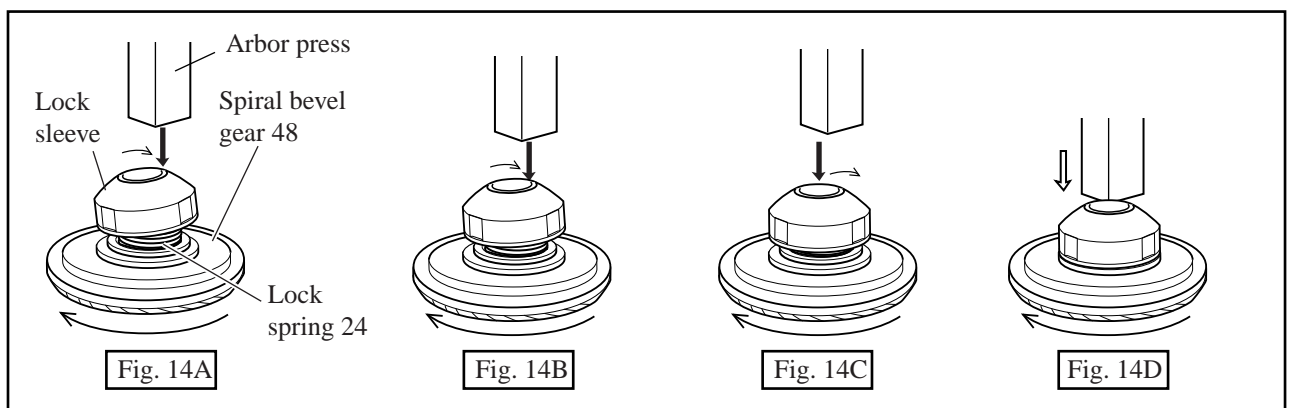
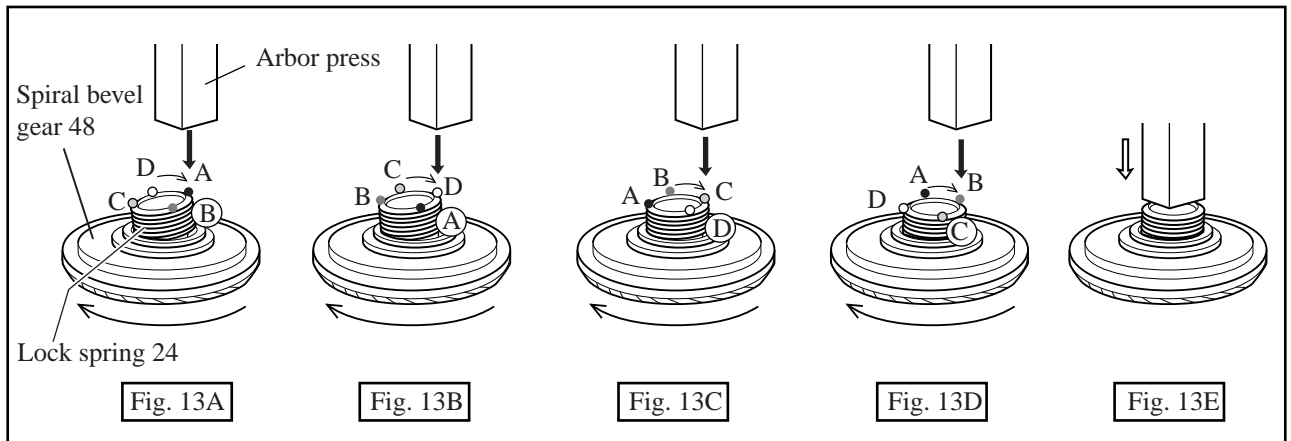

< 7 > Removing armature

- (1) After removing 4 pcs. of hex bolt M5x20, remove gear section from gear housing. And remove dust cover. See fig. 15.
- (2) Remove brush holder caps and carbon brushes, and unscrew 4 pcs. of hex bolt M5x40. Then, motor housing can be separated from gear housing. See Fig. 16.

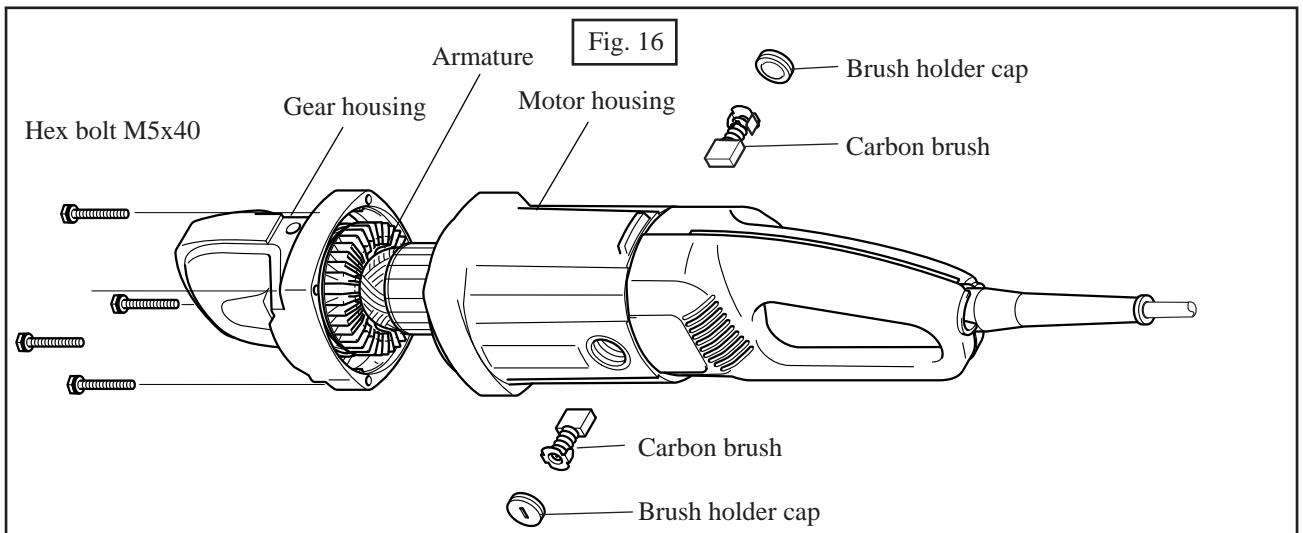
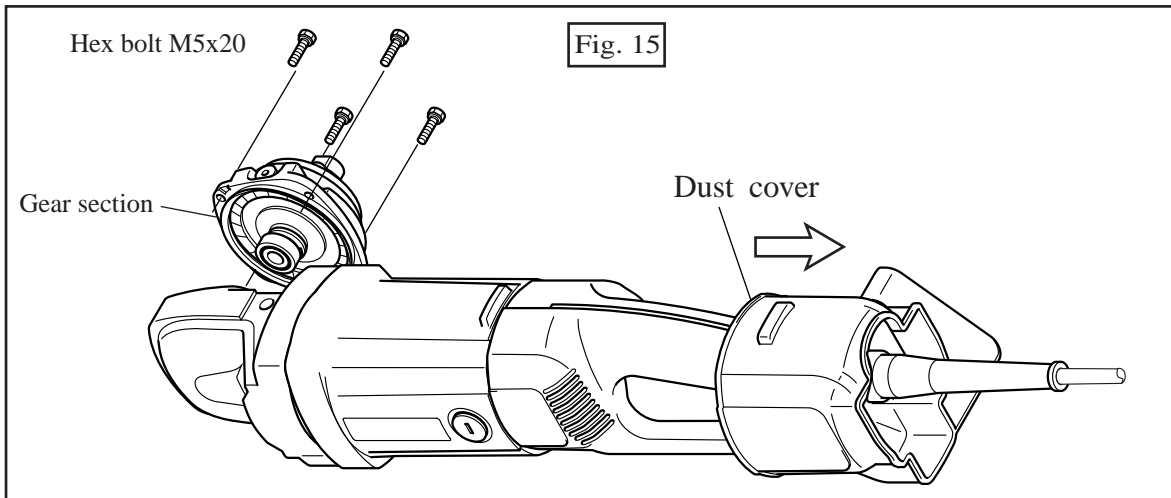

- (3) After unscrewing hex nut M8x12, remove spiral bevel gear 9 from armature shaft. See Fig. 17.

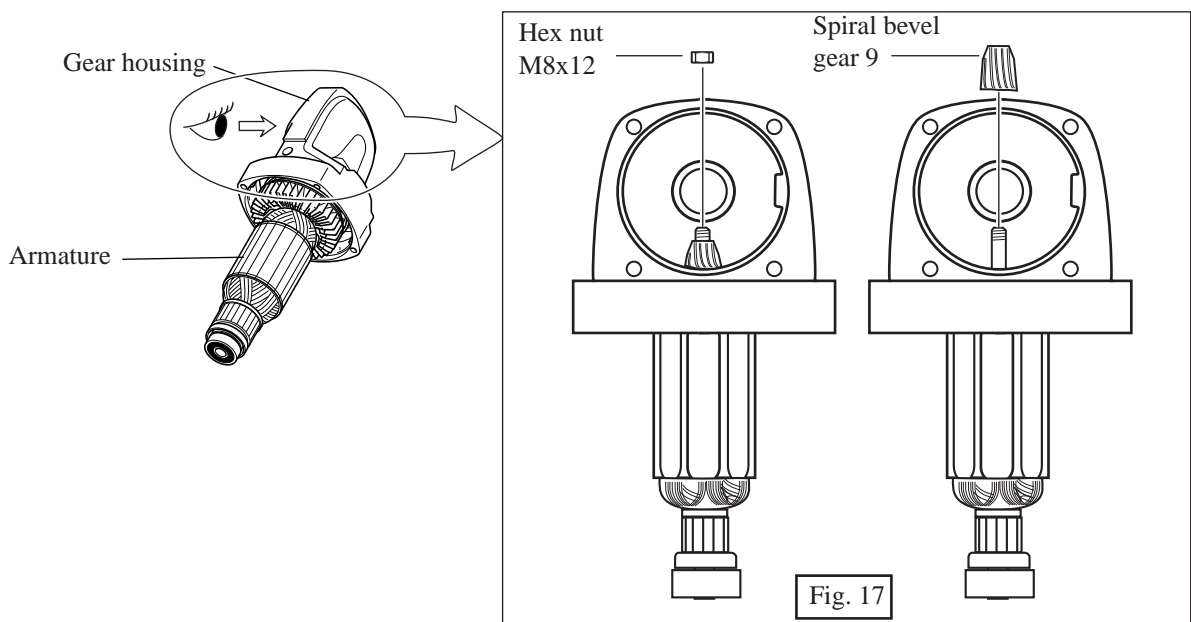

- (4) Armature can be removed together with flat washer 15 from gear housing by striking the edge of motor housing with plastic hammer. See Fig. 18.
- (5) After removing retaining ring R-40 and flat washer 30, insert the armature removed in the step (4) into the ball bearing 6202DDW. And pull out the ball bearing 6202DDW by swaying the armature. See Fig. 19.

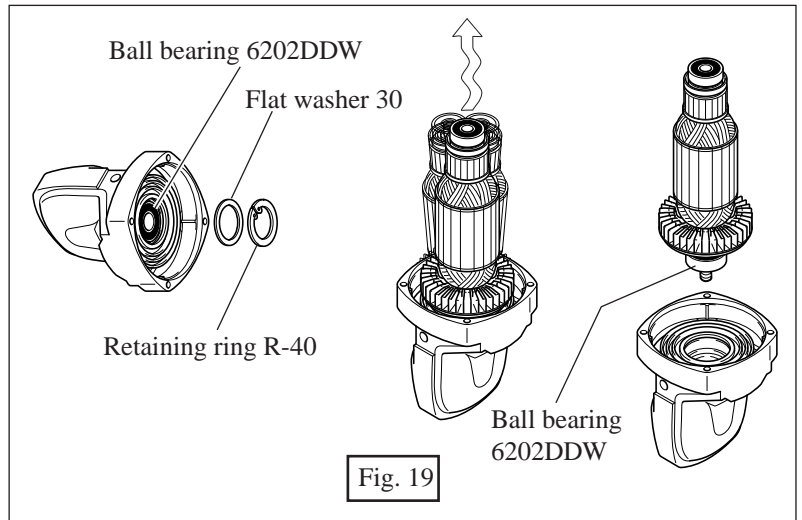
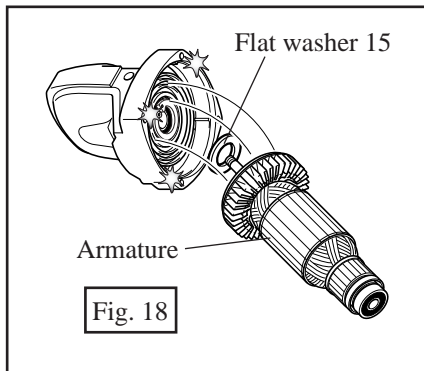

< 8 > Mounting armature

- (1) Make sure, if the rubber ring 36 remains in the gear housing. If not, mount it. Mount the parts to the gear housing in the following order.
 1. Ball bearing 6202DDW
 2. Flat washer 30
 And then, secure them with retaining ring R-40. See Fig. 20.
- (2) After mounting flat washer 15 to the armature shaft, mount the armature to the gear housing by pressing with arbor press. See Fig. 21.

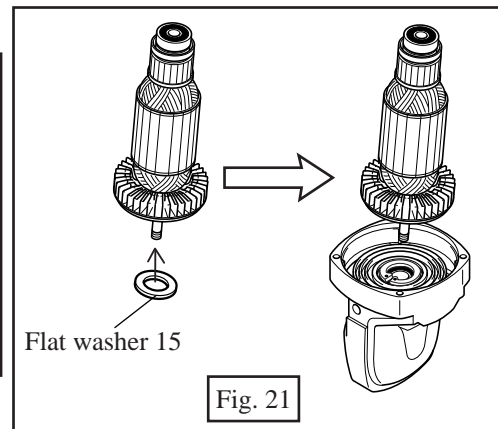
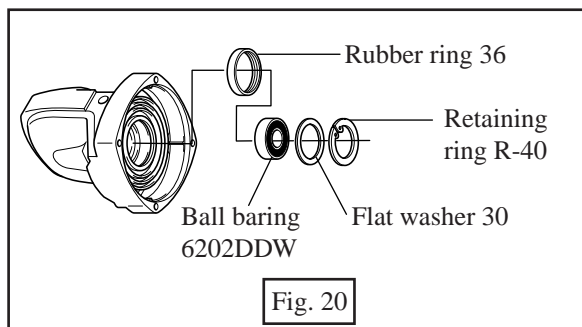

- (3) Mount spiral bevel gear 9 and secure it with hex nut M8x12. See Fig. 22.

The fastening torque of the hex nut M8x12 has to be 7.4 N.m - 15.0 N.m.

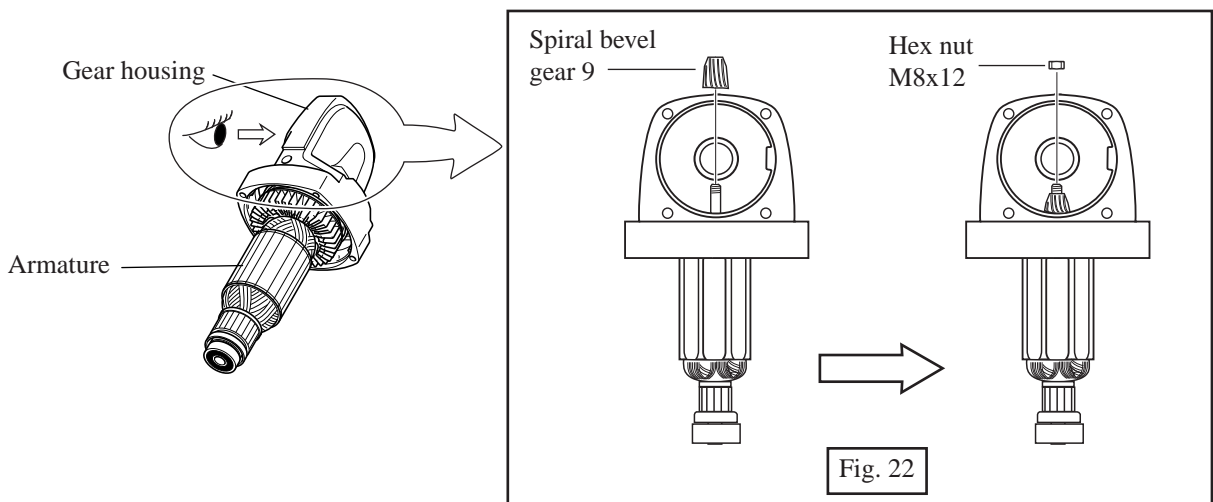

< 8 > Mounting wheel cover and base

- (1) After mounting plate B to bearing box, mount wheel cover section to the machine with aligning the hole A with the bearing box. See Fig. 25.
- (2) Aligning the three screw holes of pressure plate with the same of bearing box, mount pressure plate to the bearing box. And then, fix the pressure plate to the bearing box with 3 pcs. of hex bolt M5x14. See Fig. 26.
- (3) Fix the wheel cover section to the gear housing with 2 pcs. of hex bolt M8x20. See Fig. 27.
The mounting of wheel cover section to machine has been completed with this stage.

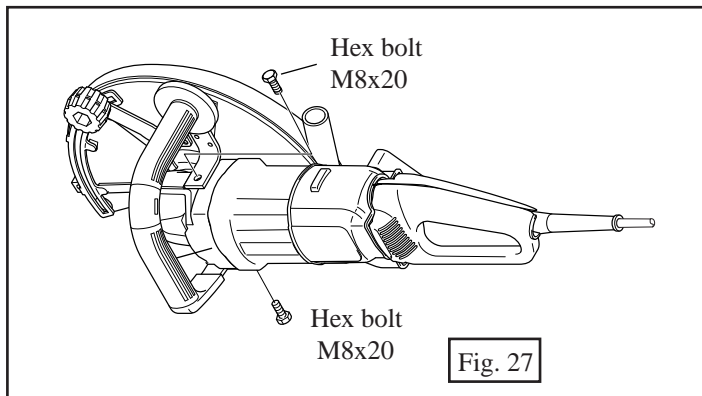
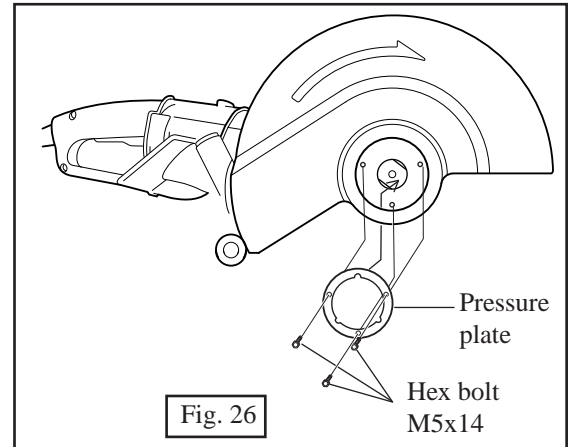
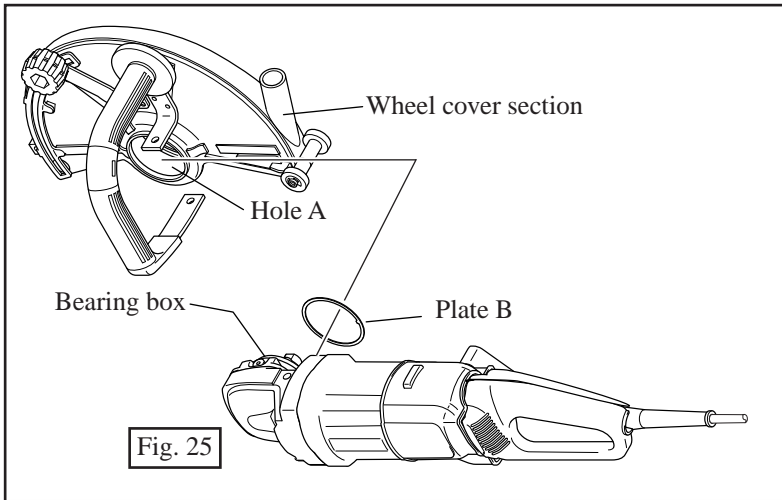

- (4) Mount base to the machine by securing with wing bolt M8x20 and 2 pcs. of hex bolt M6. See Fig. 28.

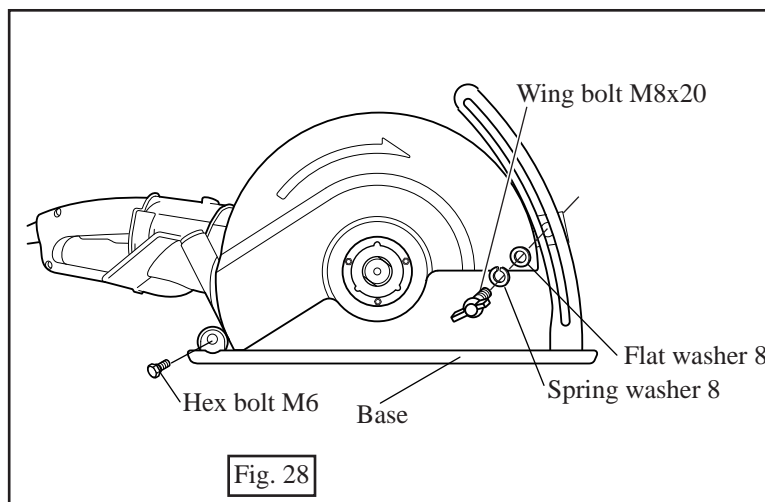





< Caution >

When repairing Model 4112H or 4112HS of **North American specification (for up to 120V)**, CB-210 has to be used for replacement of carbon brush.

Using carbon brushes other than CB-210 for 4112H and 4112HS may cause the trouble, such as melting down of motor housing, etc.



Carbon Brush CB-210

Color index of lead wires	
Black	
White	
Orange	
Purple	

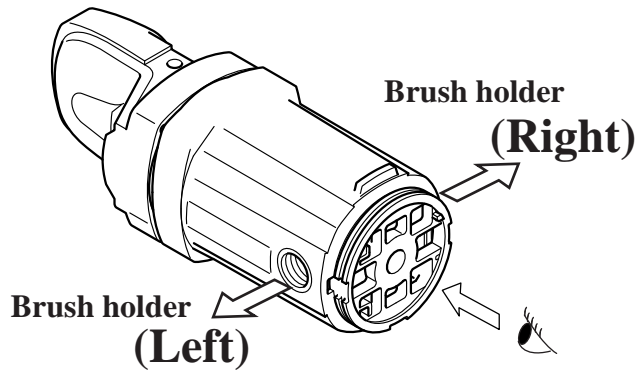

1. Circuit diagram for model 4112H

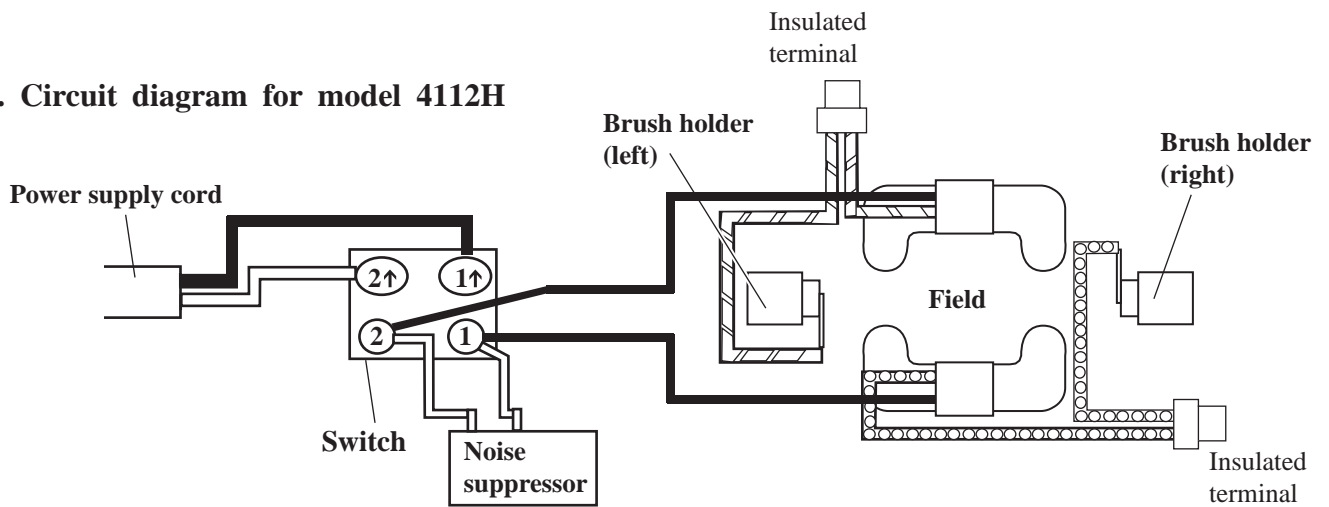

2. Circuit diagram for model 4112HS

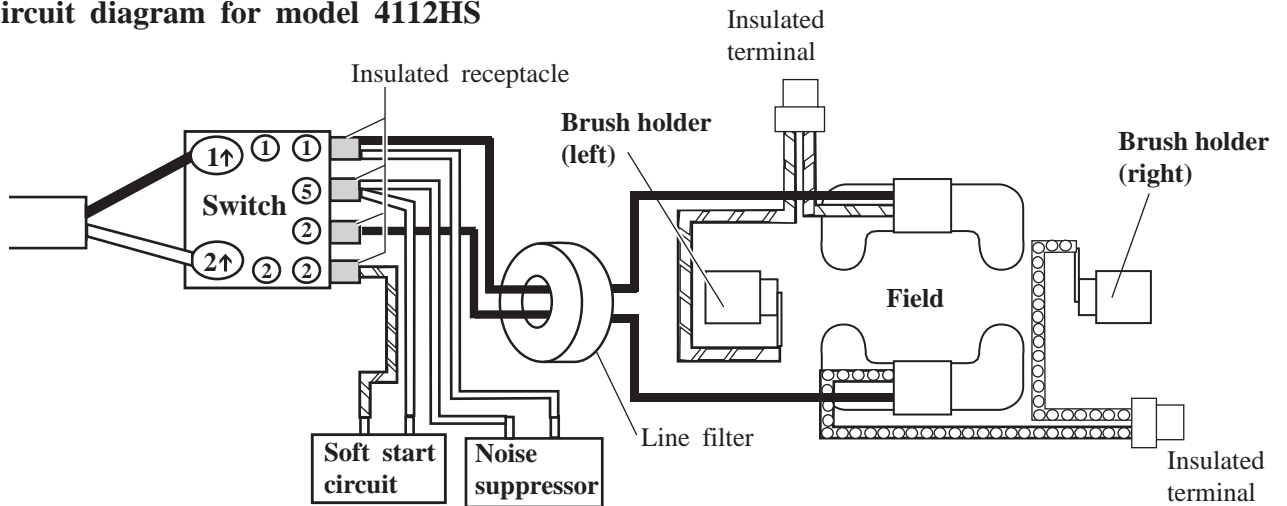

Wiring in the motor housing (Model 4112H and 4112HS)

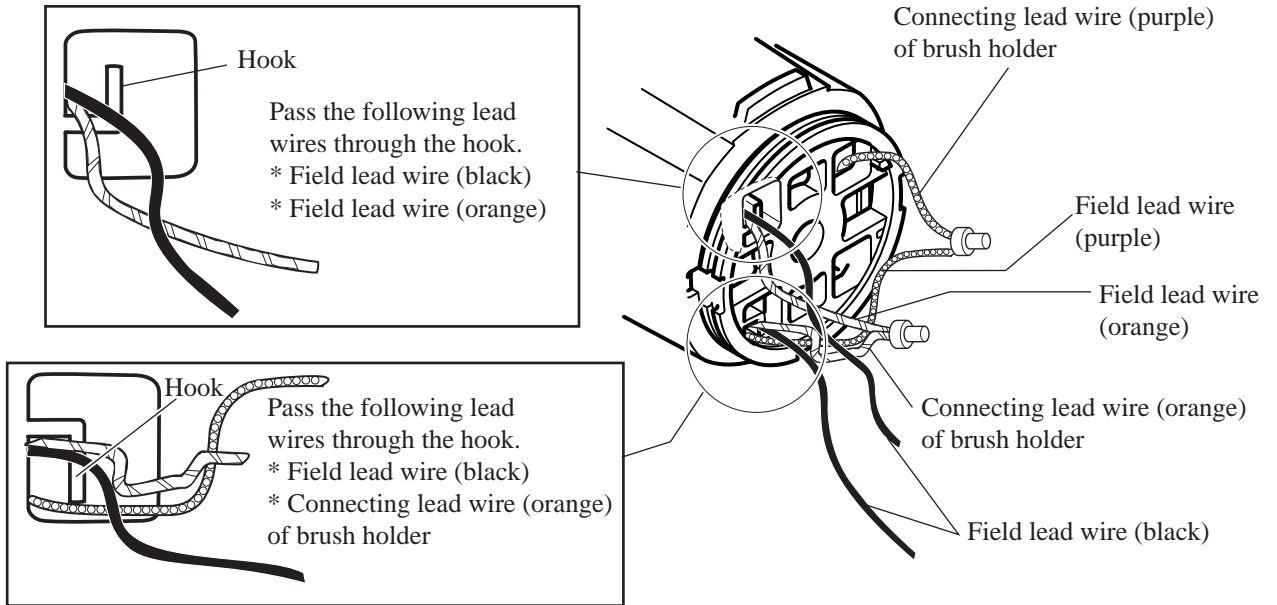

Wiring in the handle (Model 4112H)

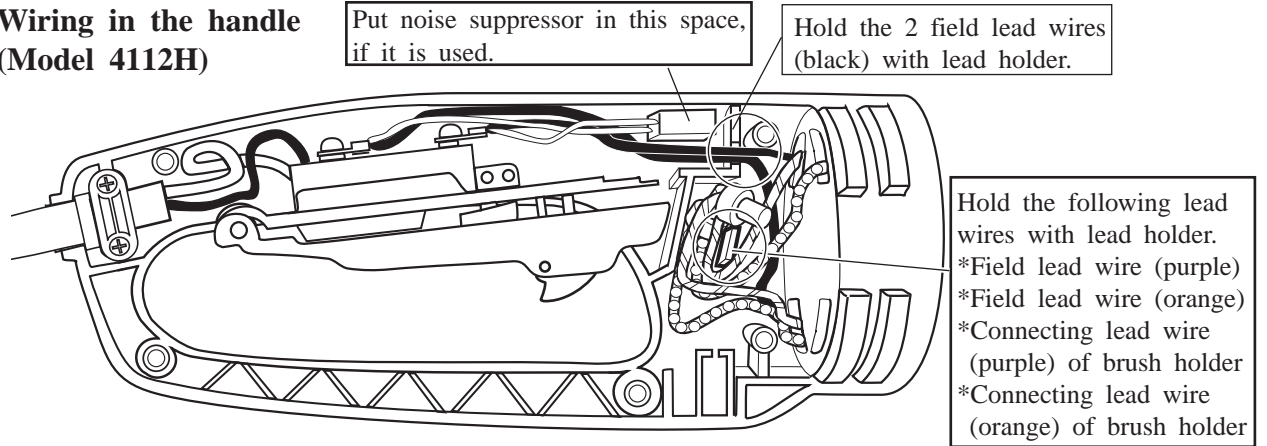

Wiring in the handle (Model 4112HS)

