

T ECHNICAL INFORMATION



PRODUCT

P 1 / 7

Models No. ▶ 4131

Description ▶ Metal Cutter 185mm (7-1/4")

CONCEPT AND MAIN APPLICATIONS

Model 4131 has been developed as a sister tool to Model 4130 for conformation to the standards of North America and Europe. The advantages of this new model are;

- *High heat-resistant motor for heavy duty applications
- *Blade service life longer than competitions thanks to "Cermet Tipped Saw Blade" and the rotation speed optimum for metal cutting
- *Trouble-free with one-touch removal of dust bag, safety cover open lever convenient for plunge cutting

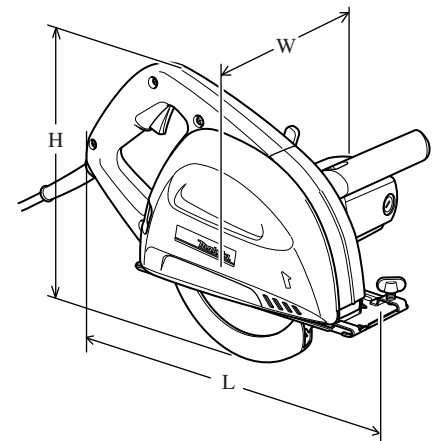

Dimensions: mm (")	
Length (L)	280 (11)
Width (W)	273 (10-3/4)
Height (H)	358 (14-1/8)

► Specification

Power input: W		1,100
Rated amperage for North America: A		13
No load speed: rpm = min.-1		3,500
Size of blade	Diameter: mm (")	185 (7-1/4)
	Hole diameter: mm (")	Europe
North America		16 (5/8)
Capacities: mm (")	Max. cutting depth	63 (2-1/2)
	Thickness of material	up to 6 (1/4)
Protection against electric shock		double insulation
Net weight: Kg (lbs.)		4.8 (10.6)
Power supply cord: m (ft)		2.5 (8.2)

► Standard equipment

- *Cermet tip saw 185mm (7-1/4") 1 pc.
- *Hex wrench 1 pc.
- *Wrench holder
- *Safety goggle 1 pc.

Note: The standard equipment for the tool shown may differ from country to country.

► Optional accessories

- *Assorted TCT Saw blade
- *Guide rule

► Repair

Always follow the instructions of the SAFETY RULES and OPERATING INSTRUCTIONS described in the instruction manual.

[1] NECESSARY REPAIRING TOOLS

- Retaining ring pliers ST-2N (1R003) For removal/installation of Safety cover
- Bearing setting pipe 16-8.2 (1R026) For removing Gear
- Ring 22 (1R217) For removing Gear
- Bearing extractor (1R263) For removing Bearing box
- Bearing extractor (1R269) For removing Ball bearing
- Retaining ring S and R pliers (1R291) For removal/installation of the Retaining ring on Spindle
- Wrench for bearing retainer (1R316) For removal/installation of Bearing retainer

[2] LUBRICATION

Put 8g of Makita grease N No.1 in the gear room of Gear housing complete.

[3] DISASSEMBLING AND ASSEMBLING

CAUTION: Be sure that the tool is switched off and unplugged before starting disassembling/assembling.

CAUTION: When using a blower for cleaning, always wear safety goggle to protect your eyes from metal dust.

[3] -1. Replacement of Base

DISASSEMBLING

- 1) Remove (+) Pan head screw M5 from the hinge portion of Base while holding Hex lock nut M5-8 with wrench 8 or the like so that it cannot turn together with the screw. (Fig. 1)
- 2) Release depth adjustment lock, and then remove Pan head screw M4x8. Now Lock plate can be removed from the depth guide of Base. Remove Hex nut M6, and now Lock lever section can be disassembled as illustrated in Fig. 2.

ASSEMBLING

Do not forget to put Flat washer 6 (Part No.253783-3) between Gear housing (blade case) and the depth guide of Base. (Fig. 3)
Be careful not to place Flat washer 6 (Part No.253804-1) there. The two Flat washers can be easily distinguished by outer diameter as illustrated in Fig. 4.

Fig. 1

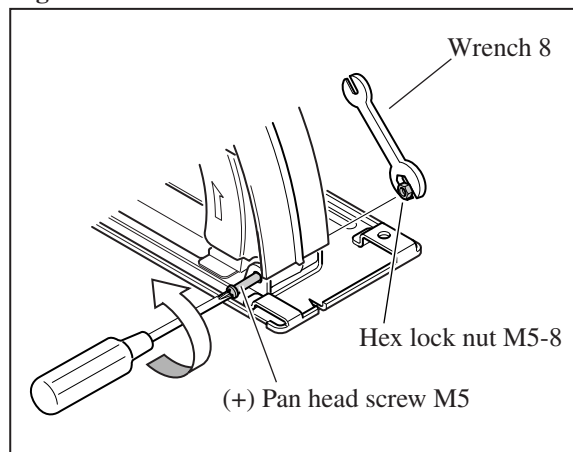

Fig. 2

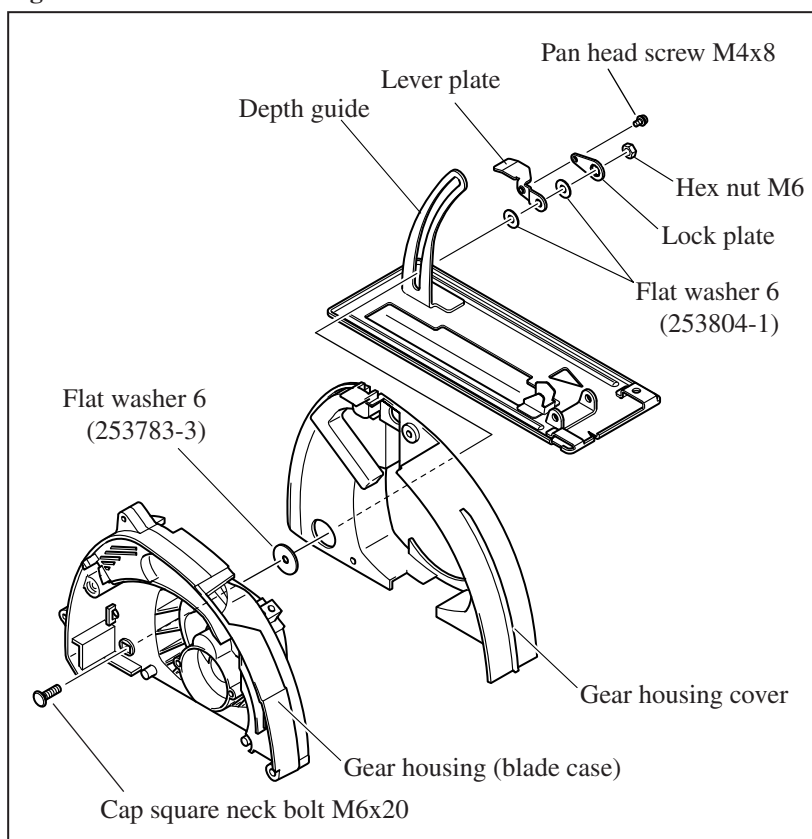

Fig. 3

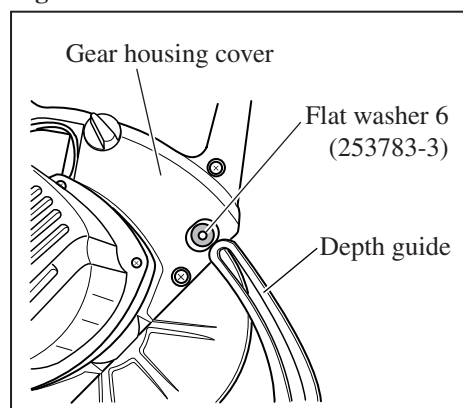
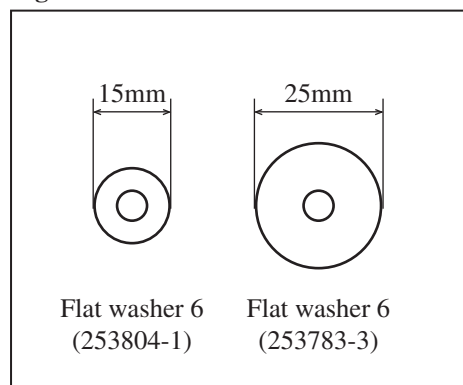

Fig. 4



► Repair

[3] -2. Disassembling Motor Section

- 1) Remove Lead cover from Gear housing cover (blade case cover) by removing Tapping screw CT4x12. (**Fig. 5**)
- 2) Remove Carbon brushes and four M5x40 Pan head screws.

Now Motor housing can be separated from Gear housing (blade case). (**Fig. 5**)

Note: Be careful not to lose the compression spring of shaft lock when taking Armature out of Motor housing.

- 3) When removing Field from Motor housing, be sure to disconnect lead wires from Trigger witch beforehand. The switch can be reached by removing two 4x18 Tapping screws and two M5x12 Pan head screws on Housing (R) side to separate Handle (R) from Handle (L). (**Fig. 6**)

CAUTION: At this time, treat the lead wires from Field carefully because they are still connected with Handle.

Fig. 5

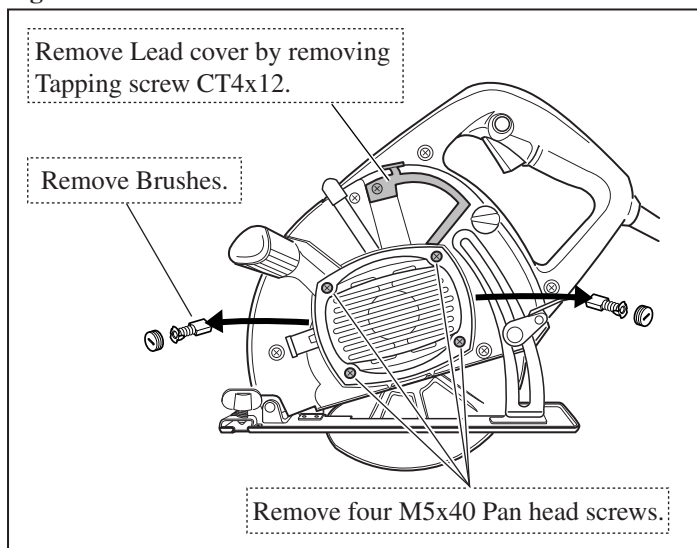
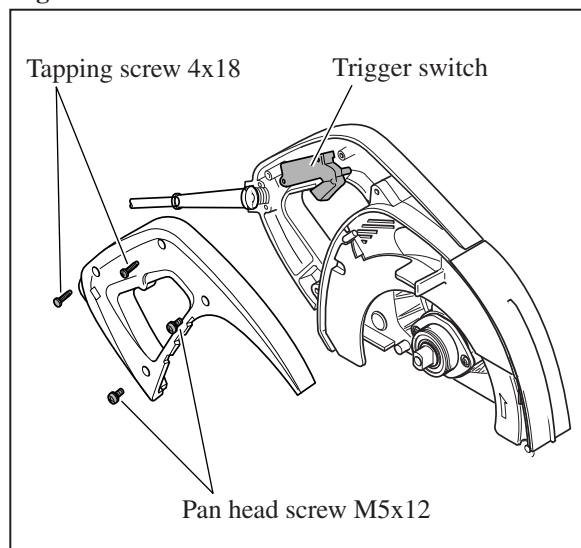

Fig. 6



[3] -3. Disassembling/Assembling of Safety Cover, Bearing Box and Gear Housing (Blade Case)

DISASSEMBLING

- 1) Remove Retaining ring on Safety cover using Retaining ring pliers ST-2N (1R003).
At this time, hold the ring with gloved hand so that it cannot fly off.
- 2) By removing Safety cover, three parts can be disassembled in the following order;
Washer 42/ Spacer/ Thickness ring (See **Fig. 7**.) Remember this order for reassembling.
- 3) If Safety cover does not move smooth, remove metal dust from each part and apply machine oil.
- 4) Bearing box can be removed by removing two M5x12 (+) Countersunk head screws. (**Fig. 8**)
If it is hard to remove, turn Bearing box a little, and then lift it up using two Bearing extractors (1R263).
Note: When reinstalling the countersunk head screws, apply an appropriate amount of THREE BOND 1321B/1342 or LOKTITE 242 to them before tightening.

ASSEMBLING

Note: Place Thickness ring inside Spacer.

Fig. 7

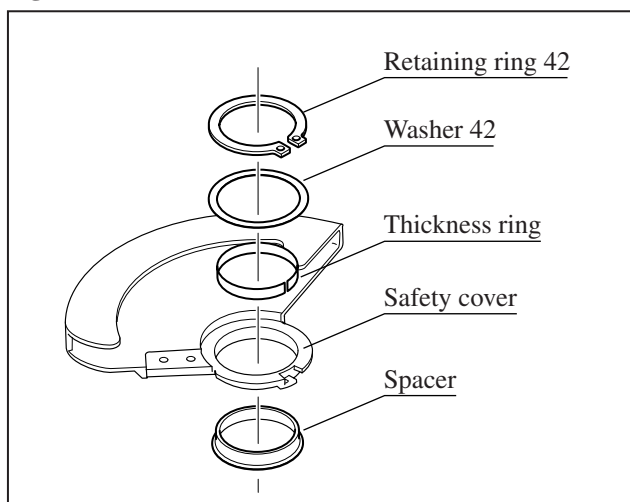
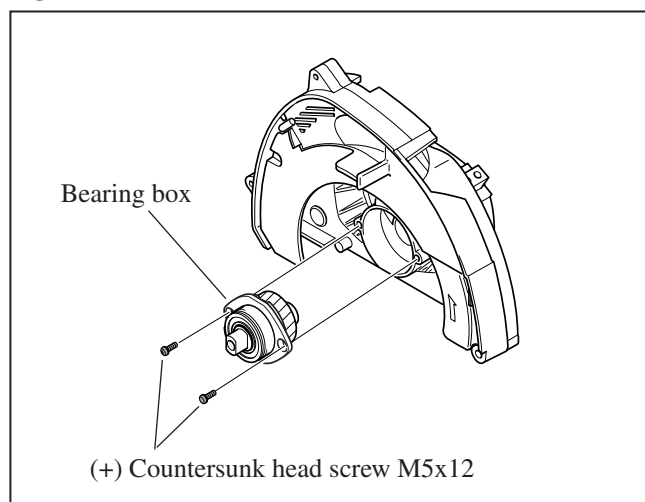

Fig. 8



► Repair

[3] -4. Removing Safety Cover Open Lever

Remove Rubber cap from Open lever beforehand because it can catch on other parts to prevent removal of Open lever. (Fig. 9)

Fig. 9

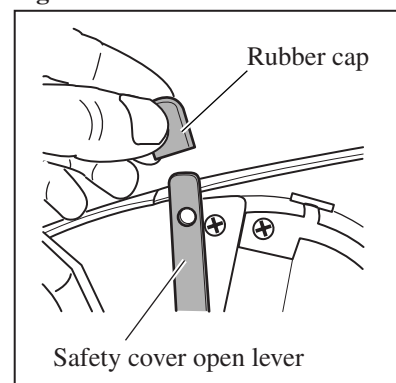

[3] -5. Replacement of Helical Gear 48 and Ball Bearings 6202DDW/608LLB

- 1) Remove Bearing box as described in "3. Disassembling/Assembling of Safety Cover, Bearing Box and Gear Housing (Blade Case)".
- 2) Remove Ball bearing 608LLB with Bearing extractor (1R269).
- 3) Remove Retaining ring S-15 with Retaining ring S and R pliers (1R291) as illustrated in Fig. 10.
- 4) Remove Bearing retainer (left-handed) by turning clockwise using Wrench for bearing retainer (1R319). (Fig. 11)
- 5) Place Bearing box on Ring 22 (1R217), and put Bearing setting pipe 16-8.2 (1R026) on the gear installation end of Spindle. Press Spindle out using arbor press to remove Helical gear 48 and Ball bearing 6202DDW. (Fig. 12)

Fig. 10

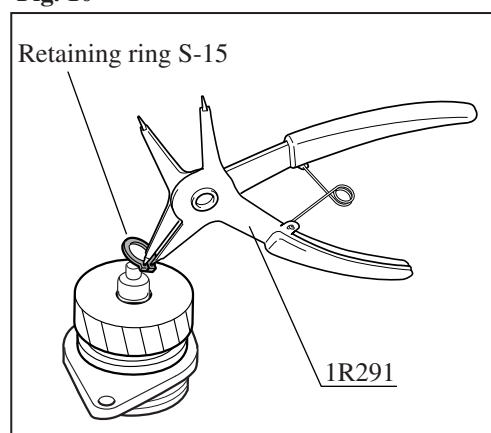

Fig. 11

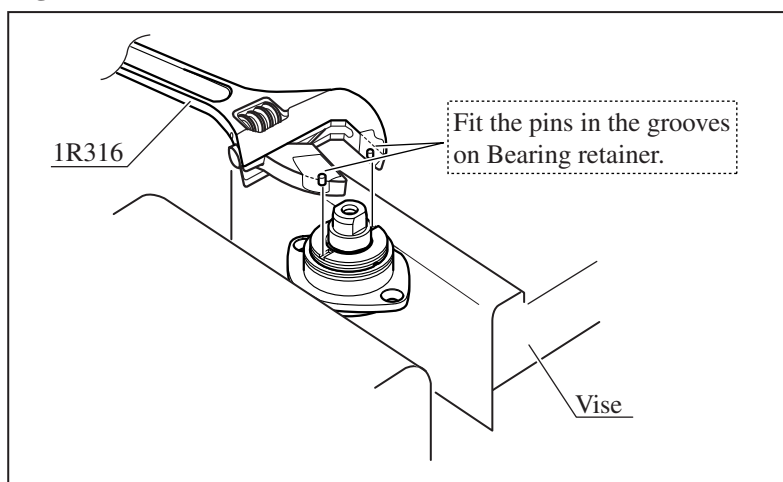
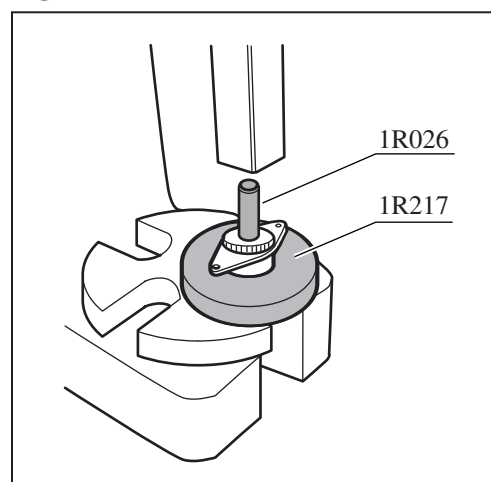

Fig. 12



[3] -6. Replacement of Switch and Power Supply Cord

Note: Switch and Power supply cord can be replaced without removing Motor section and Gear housing (blade case).

- 1) Remove two 4x18 Tapping screws.
- 2) Remove Handle (R) by removing two M5x12 Pan head screws on Housing (R) side. (See Fig. 6 on page 3.)
- 3) Now Switch and Power supply cord can be replaced.

► Repair

[3] -7. Disassembling Dust Case

See Fig. 13 when replacing Heat resisting glass and Punching metal cover. (Fig. 9)

Fig. 13

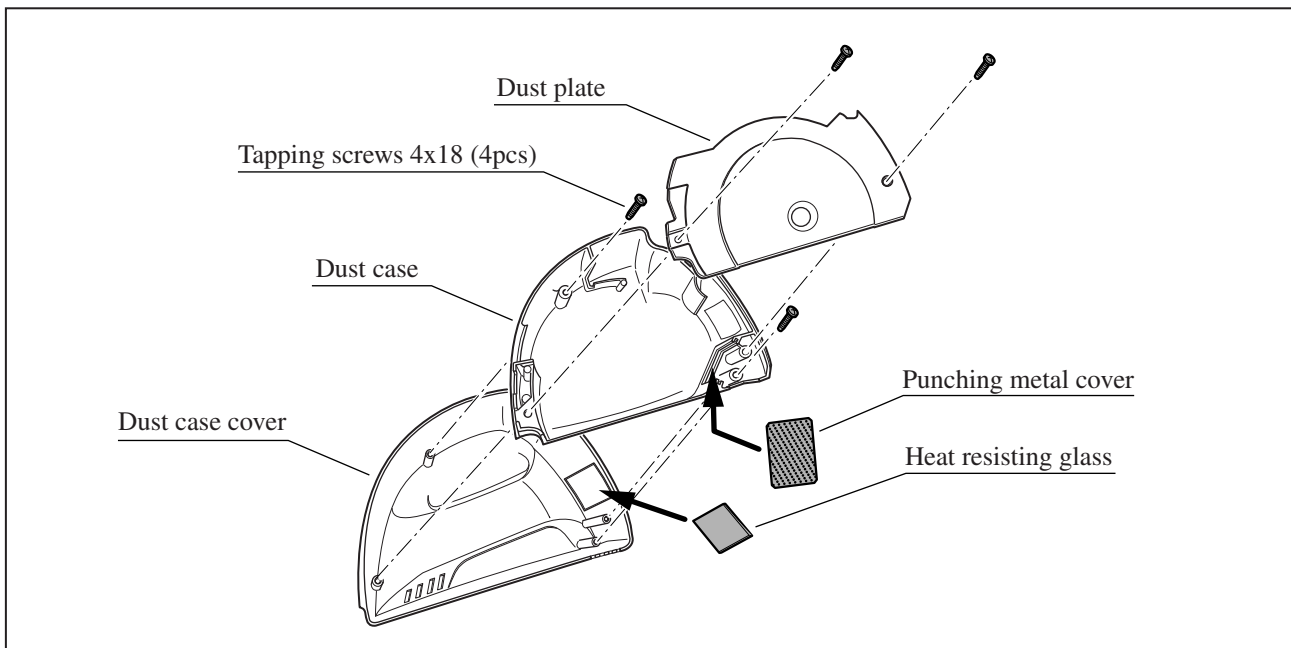

[4] ADJUSTMENT

[4] -1. Hinge Portion of Gear Housing (Blade Case)

Fasten Gear housing (blade case) to Base so that cutting depth can be adjusted smoothly without wobbling. (Refer to "1. Replacement of Base" and Fig. 1 on page 2)

[4] -2. Lever Plate of Cutting Depth Lock Lever

Fix Lock plate to Lock lever so that the line through Cap square neck bolt M6x20 and Pan head screw M4x8 forms an angle of approximately 10 to 30 degrees to the horizontal axis when the lever is locked. (Fig. 14)

Fig. 14

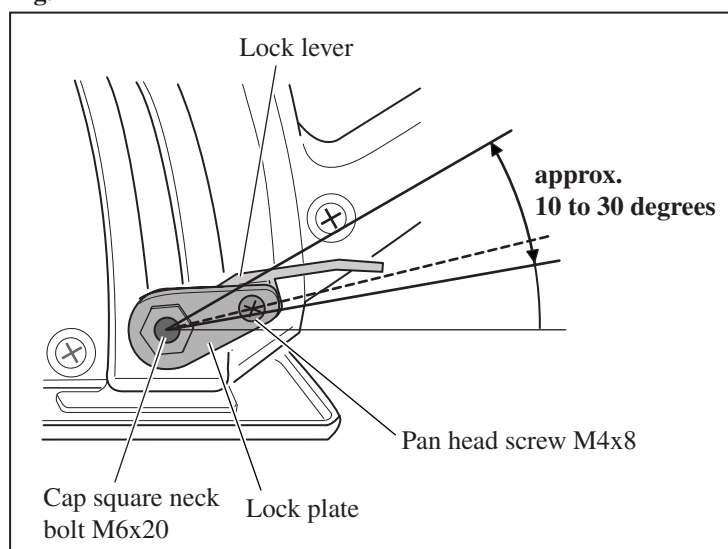

► **Circuit diagram**

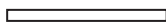
Color index of lead wire	
Black	
White	

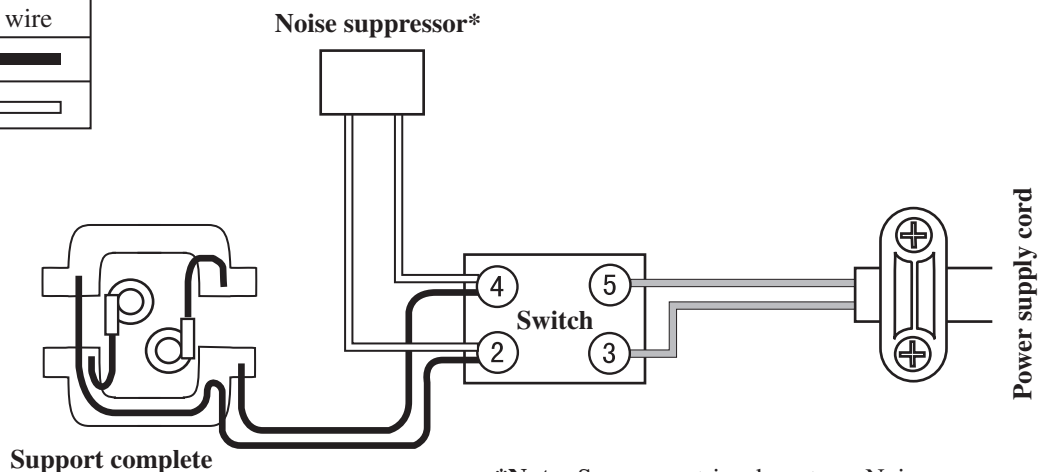

*Note: Some countries do not use Noise suppressor.

► **Wiring diagram**

[Wiring of Lead Wires from Support Complete]

1) At Motor Housing and Baffle Plate Portions

Route as illustrated in Fig. 15.

Fig. 15

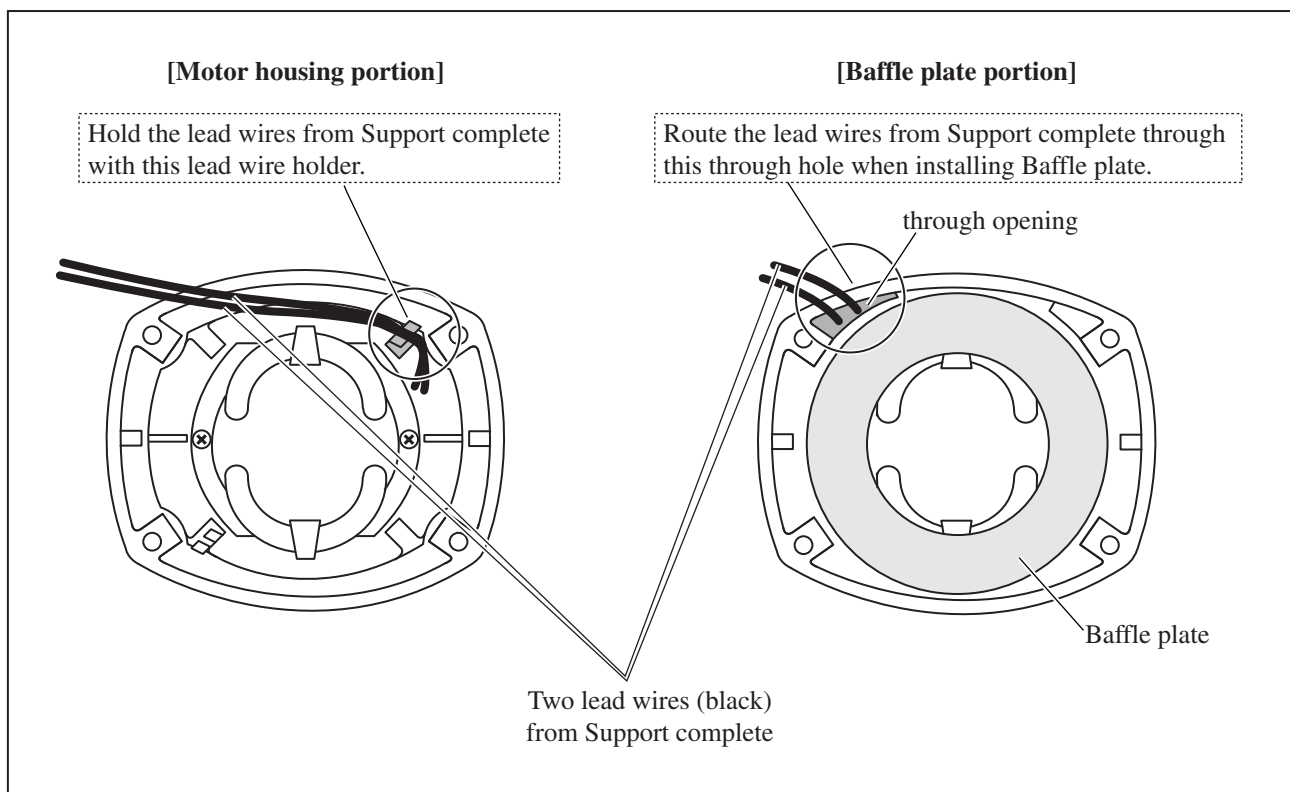

► Wiring diagram

[Wiring of Lead Wires from Support Complete]

2) In Gear Housing Cover

Route as illustrated in Fig. 16.

3) In Handle

Route as illustrated in Fig. 17.

Fig. 16

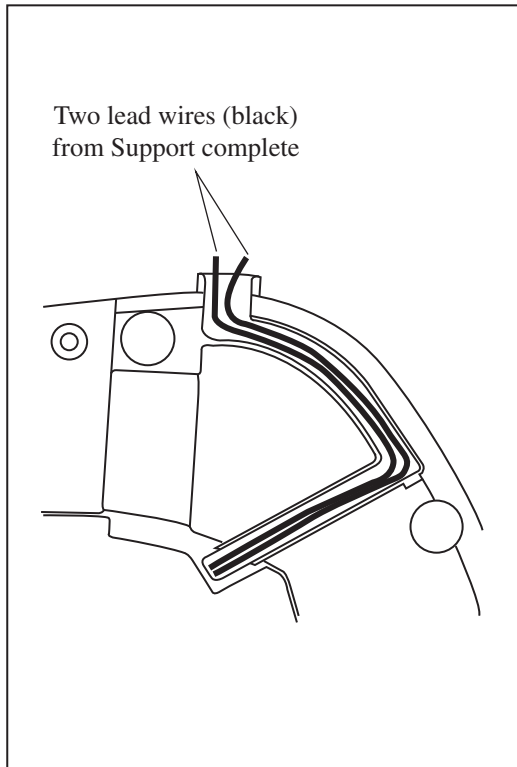

Fig. 17

