

T ECHNICAL INFORMATION



New Tool

Models No. ▶ 4190D

Description ▶ MAKITA 80 mm Battery cutter

CONCEPT AND MAIN APPLICATIONS

This machine, wherein the bevel cutting function capable of angle-cutting (45"cutting) for the tile etc. is additionally built in the model 4103D(80 mm cordless diamond cutter), has been developed to enlarge the application range.

The 4190D is the model without the charger and diamond wheel.

The 4190DW is made through the combination of 4190D, Battery, charger and diamond wheel.

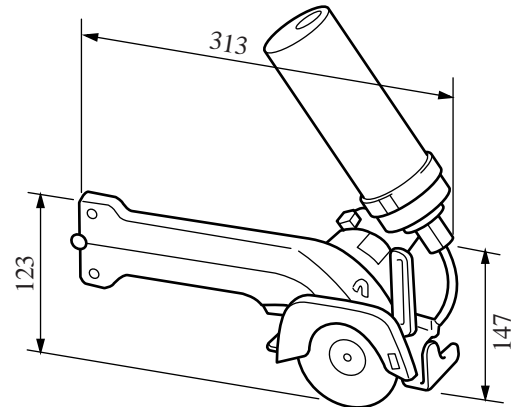

(The height of the water supply unit is not included)

▶ Specifications

Motor	DC 9.6 V magnet motor
No load speed (R.P.M.)	1000/min.
Overall length of machine	460 mm
Max. cutting depth	0-18 mm in the right angle, 0-16 mm in beveling at 45
Inner diameter (mm)	15
Net weight	1.9 kg(Battery included)
Power supply cord	

▶ Standard equipment

Diamond wheel 80(for wet-type) --- Only for 4190DW

Hexagon rod spanner 4 --- Attached on the body

▶ Optional accessories

Diamond wheel 80

Battery 9600

Rubber plate(For holding the bottom of base, for preventing the material surface to be cut from damaging)

The standard equipment for the tools shown may differ form country to country

► Repair

- (1) Conform to the 4130D.
- (2) Check if the clearance between the edge of water supply tube and the diamond wheel is the one as shown on the figure 1. If extremely out-of-positioned, adjust the water supply tube.

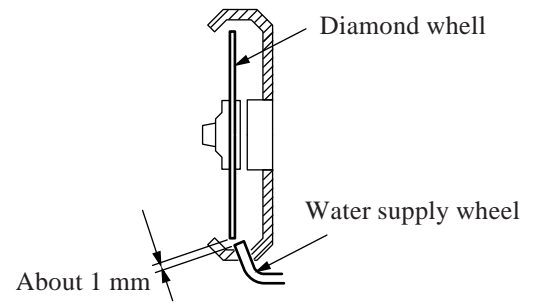

[Figure 1]