

T ECHNICAL INFORMATION

Makita

New Tool

Models No. ▶ 4300BV

Description ▶ MAKITA Jig saw

CONCEPTION AND MAIN APPLICATIONS

The variable speed function is additionally built into the same functions of the #4300A and 4300BA to enlarge the application range, so that the cutting can be done at the best stroke speed for the material to be cut.

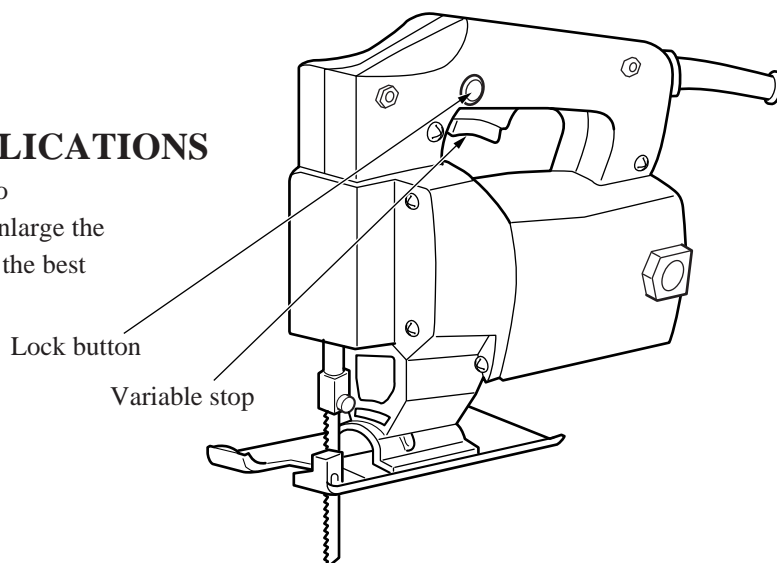

▶ Specifications

The stroke frequency under no load is 0 - 3100 RPM/min. instead of 3100/min. Other features are same as #4300A and 4300BA.

▶ Accessories

The standard and optional accessories are same as #4300A and #4300BA.

▶ Standard and optional

In addition to the built-in non-step variable speed switch or the same function of the model 6000R, the switch stroke speed adjusting screw(variable stop) is mounted, so that you can get the given stroke speed if the trigger is pulled at full with set at the desired stroke speed, and you cannot pull the trigger anymore. Just like the normal switch, also the lockbutton, which can be fixed at each stroke, is mounted. Other features are same as 4300A and 4300BA.