

# T ECHNICAL INFORMATION



**Models No.** ▶ 4304T

**Description** ▶ JIG SAW

## CONCEPTION AND MAIN APPLICATIONS

Model 4304T is a top-handle version of Model 4305T. "T" means "Tool-less. You can prepare for your work without "Tool".  
Blade change, Bevel cutting adjustment, attaching the Vacuum head for dust collecting.

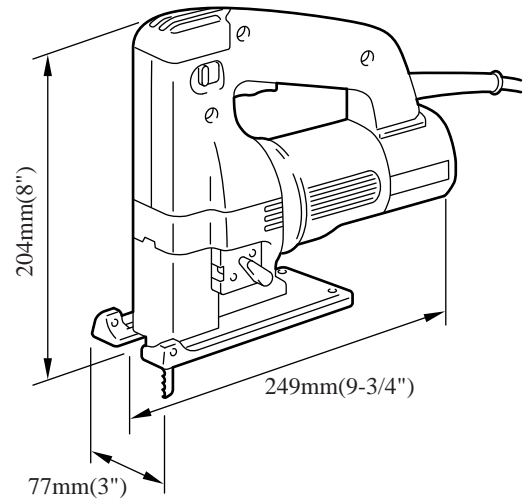

### ► Specifications

| Voltage (V) | Current (A) | Cycle (Hz) | Continuous Rating (W) |        | Max. Output(W) |
|-------------|-------------|------------|-----------------------|--------|----------------|
|             |             |            | Input                 | Output |                |
| 100         | 6.0         | 50/60      | 580                   | 320    | 600            |
| 115         | 5.5         | 50/60      | 600                   | 350    | 600            |
| 220         | 2.9         | 50/60      | 600                   | 350    | 600            |
| 230         | 2.7         | 50/60      | 600                   | 350    | 600            |
| 240         | 2.6         | 50/60      | 600                   | 350    | 600            |

|                           |                   |  |
|---------------------------|-------------------|--|
| <b>Length of stroke</b>   |                   | 26mm(1")   |
| <b>Cutting capacities</b> | Wood              | 110mm (4-3/8") when using the jig saw blade B-16L. |
|                           | Mild steel        | 10mm (3/8")  |
|                           | Aluminum          | 20mm (13/16")                                      |
|                           | Stroke per minute | 500-3,000  |
|                           | Net weight        | 2.3 kg (5.1 lbs.)                                  |

### ► Standard equipment

Jig Saw Blade B-10, BR-13, B-22 (2 pcs. each), Plastic Cover, Plastic Base Plate, Anti-Splintering Device, Hex Wrench 3

### ► Optional accessories

Circular Guide, Guide Rule (Rip Fence), Vacuum Head, Hose, Various types of Jig Saw Blades

## ► Repair

Repair in the same way as 4304 and 4305 other than shown below.

### \*Assembling of Balance plate

Assemble as shown on the right figure as the balance plate has directions in left/right.

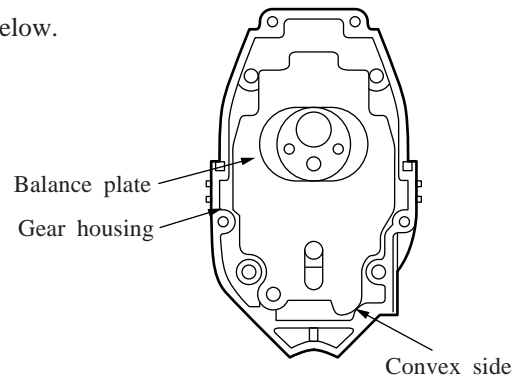

### \*Assembling of Base

When fixing the base, fasten the flanged hexagon nut M5 in a way that the lever 65 can be placed within the position range shown on the figure. (Reference : 45-55kgf/cm(3.3-4.0ft-lbs))

Use the pan head screw M4X8 to prevent the flanged hexagon nut M5 from turning.

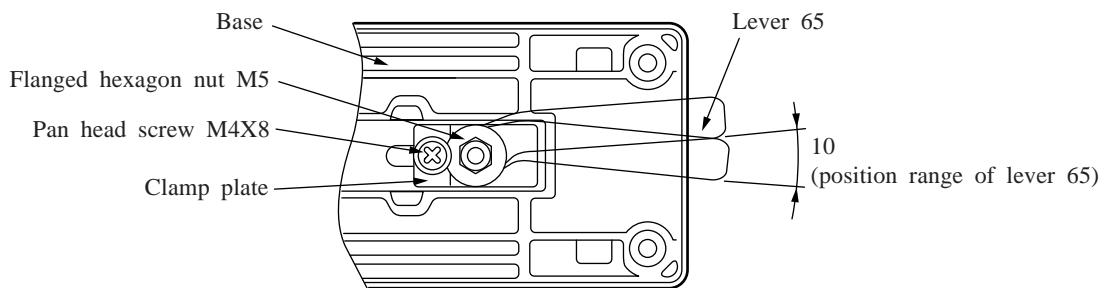

### \* Disassembling/assembling of blade fix (see the below figure)

#### Disassembling of the blade fix

1. Turn the blade lever (4304T) or blade thumb screw (4305T) in left turning direction until they have stopped turning.
2. Turn in left the blade fix protruded over the rod to remove the blade fix.

#### Assembling of the blade fix

1. Make sure that the blade lever or the blade thumb screw has been turned in left turning direction until stopped in turning.
2. Screw the blade fix into the rod in 1/4-1 turn.
3. Pick up the blade fix by fingers while using care not to turn it and turn in right turning direction the blade lever or the blade thumb screw to set them into the rod.

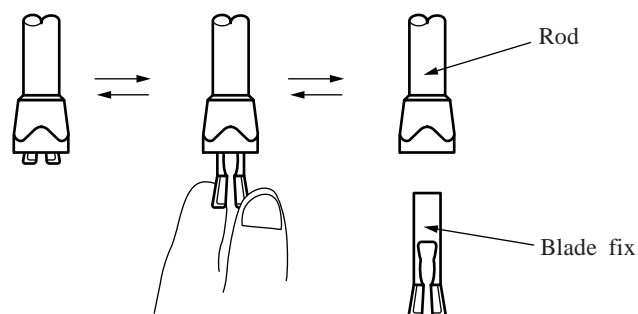

## ► Circuit drawing

Same as 4304 and 4305.