

# T ECHNICAL INFORMATION



New Tool

**Models No.** ▶ 4305

**Description** ▶ Jig Saw

## CONCEPTION AND MAIN APPLICATIONS

Model 4305 is a variable speed orbital action jig saw with new body-grip and knob design.

One straight and three different orbital cutting actions allow fast, smooth cutting in steel, wood, plastics, aluminum, etc.

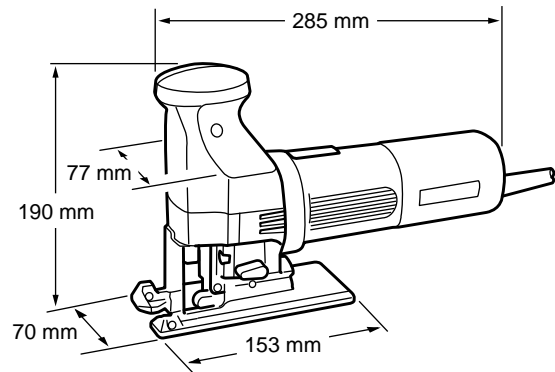

### ► Specifications

Voltage (V)	Current (A)	Cycle (Hz)	Continuous Rating (W)		Max. Output(W)
			Input	Output	
100	6.0	50/60	580	320	600
115	5.5	50/60	600	350	600
220	2.9	50/60	600	350	600
230	2.7	50/60	600	350	600
240	2.6	50/60	600	350	600

Length of stroke		26 mm (1")
Cutting capacities	Wood	110 mm (4-3/8") when using the jig saw blade - l6L.
	Mild steel	10 mm (3/8")
	Aluminum	20 mm (13/16")
Stroke per minute		500 - 3,000
Net weight		2.3 kg (5.1 lbs)

### ► Standard equipment

Jig Saw Blade B-10, BR-13, B-22 (2 pcs. each), Plastic Cover, Plastic Base Plate, Anti-Splintering Device, Hex Wrench 3

### ► Optional accessories

Circular Guide, Guide Rule (Rip Fence), Vacuum Head, Hose, Various types of Jig Saw Blades

The standard equipment for the tools shown may differ from country to country