

T ECHNICAL INFORMATION



New Tool

Models No. ▶ 4320

Description ▶ MAKITA Jig Saw

CONCEPTION AND MAIN APPLICATIONS

Based on the existing model #4301SV, the jigsaw having the same capacity and function is compacted for size less weight and less cost.

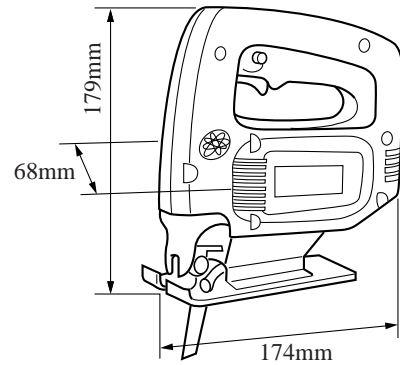

▶ Specifications

Voltage(V)	Current(A)	Frequency(Hz)	Consumed power(W)	Rated output(W)	Max. output(W)
100	3.3	50-60	310	160	250
115	2.9	50-60	310	160	250
200	1.7	50-60	310	160	250
220	1.5	50-60	310	160	250
230	1.4	50-60	310	160	250
240	1.4	50-60	310	160	250

No load speed (stroke/min.)		0-3200
Capacity	Wood(mm)	50
	Soft steel plate(mm)	6
Bevel cutting		0-45 in left/right
Net Weight(kg)		1.3
Cord length(m)		2

▶ Standard equipment

1. Circular guide
2. Guide rule
3. Hex. wrench 3
4. Jigsaw blade No.1, No.2, No.3(each 2 pieces)
5. Rule holder
6. Hex. shank Hd. screw M5X10

*The 5.and 6.are used for mounting the guide.

▶ Optional accessories

Jigsaw blade No.1, No.2, No.3, No.4, No.5, No.6, No.7, No.8, No.9, No.10, No.16, No.17, No.41, No.42

The standard equipment for the tools shown may differ from country to country.