

TECHNICAL INFORMATION



PRODUCT

P 1 / 14

Model No. ▶ 4341CT, 4341FCT

Description ▶ Jig saw

CONCEPT AND MAIN APPLICATIONS

The above mentioned body handle type jig saw is the advanced version of the existing model 4305T series.

Its brief benefits and features are

- * New tool less blade change system
- * Incredibly low vibration and noise level
- * Built-in electronic for keeping constant speed and soft start
- * Pre-setting speed dial for optional speed setting

In addition to the above features, Model 4341FCT

is equipped with LED job light for easy tracing your cutting line.

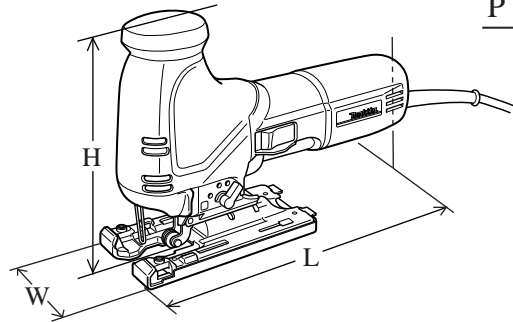

Dimensions : mm (")	
Length (L)	271 (10-11/16)
Height (H)	188 (7-3/8)
Width (W)	73 (2-7/8)

Specification

Voltage (V)	Current (A)	Cycle (Hz)	Continuous Rating (W)		Max. Output(W)
			Input	Output	
120	6.3	50 / 60	720	320	700
220	3.4	50 / 60	720	320	700
230	3.3	50 / 60	720	320	700
240	3.2	50 / 60	720	320	700

Strokes per min. : spm.= min.-1		800 - 2,800
Length of Stroke : mm (")		26 (1)
Blade shank	BOSCH Type	Yes
	MAKITA Type	
Orbital action of blade		Yes / 3 stages
Max. cutting capacities : mm (")	Wood	* 135 (5-5/16)
	Mild Steel	10 (3/8)
	Aluminum	20 (25/32)

Electronic	Speed control	Yes
	Soft start	Yes
	Variable speed	Yes
Protection from electric shock		by double insulation
Net weight : Kg (lbs.)		2.4 (5.3)
Cord length : m (ft)		2.5 (8.2)

* With attaching jig saw blade No. B-16L(optoinal accessory),

Standard equipment

- * Jig saw blade set (including B-10: 2 pcs., BR-13: 2 pcs., B-22: 2 pcs.)..... 1 set
- * Cover plate 1 pc.
- * Kerf board 1 pc.
- * Hex wrench 1 pc.
- * Dust nozzle (only for Europe) 1 pc.
- * Plastic carrying case 1 pc.

< Note > The standard equipment for the tool shown may differ from country to country.

Optional accessories

- | | | | |
|-----------------------|-------------------------|-------------------------|--------------------------|
| * Guide rule | * Jig saw blade No.B-8 | * Jig saw blade No.B-17 | * Jig saw blade No.B-26 |
| * Guide rail set | * Jig saw blade No.B-10 | * Jig saw blade No.B-18 | * Jig saw blade No.B-27 |
| * Guide rail adaptor | * Jig saw blade No.B-11 | * Jig saw blade No.B-19 | * Jig saw blade No.B-16L |
| * Kerf board | * Jig saw blade No.B-12 | * Jig saw blade No.B-21 | * Jig saw blade No.BR-13 |
| * Dust nozzle | * Jig saw blade No.B-13 | * Jig saw blade No.B-22 | * Plastic base plate |
| * Hose | * Jig saw blade No.B-14 | * Jig saw blade No.B-23 | |
| * Jig saw blade No.51 | * Jig saw blade No.B-15 | * Jig saw blade No.B-24 | |
| * Jig saw blade No.58 | * Jig saw blade No.B-16 | * Jig saw blade No.B-25 | |

< 1 > Lubrication

Apply MAKITA grease FA. No.2 to the portions marked with black triangle, and machine oil No.120 to the portions marked with gray triangle to protect parts and product from unusual abrasion.

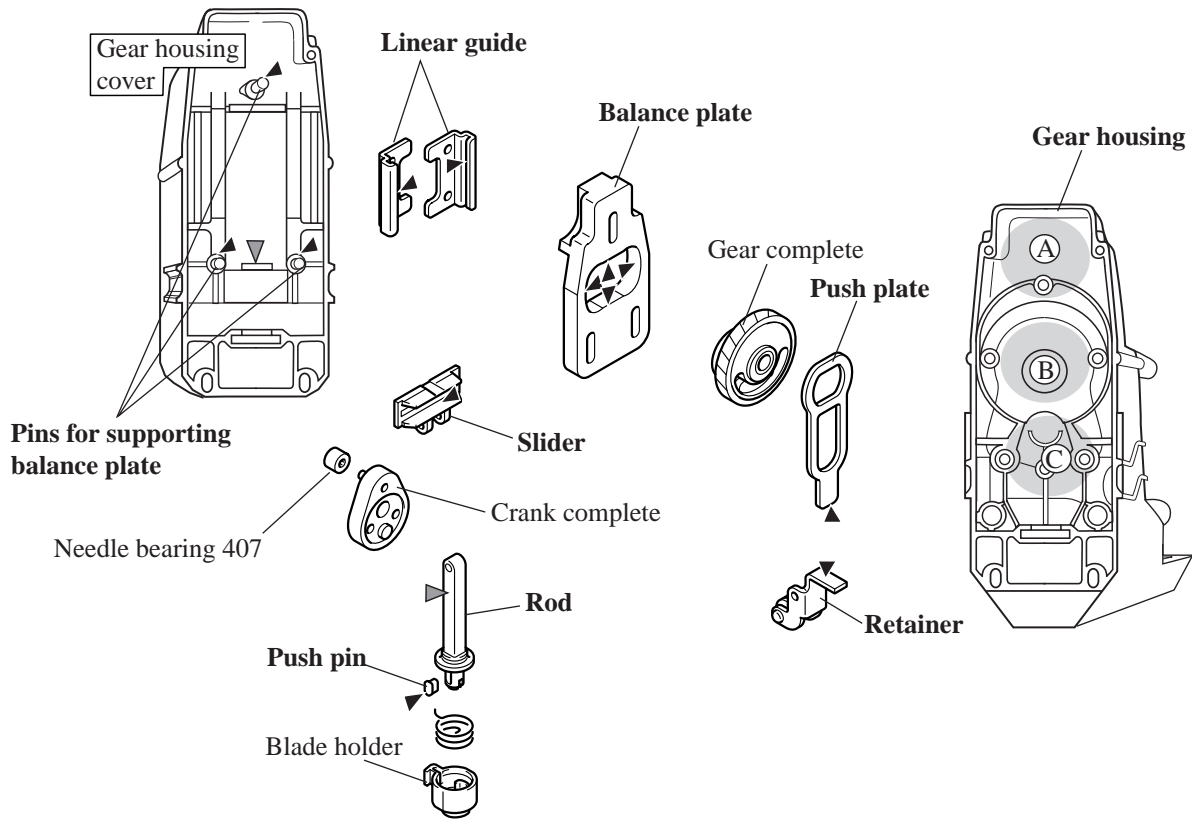

Lubricant to be applied	Parts' name	The portion to be lubricated
MAKITA grease FA. No.2	Gear housing	The positions painted with gray
	Balance plate	The portion where contacts gear complete.
	Gear housing cover	The three pins which supports balance plate.
	Push plate	The portion where contacts retainer.
	Retainer	The portion where contacts push plate.
	Linear guides	The portion where contacts slider.
	Slider	The portion where contacts needle bearing 407.
Machine oil No.120	Push pin	Its whole part
	Gear housing cover	The hole where the rod reciprocates.
	Rod	The portion where contacts dust seal.

< 2 > Disassembling tool opener

1. Separate base from the jig saw unit by unscrewing hex socket head bolt M5x18. See Fig. 1.
2. Unscrew pan head screw M4. Then tool opener and torsion spring 6 can be disassembled. See Fig. 1A.

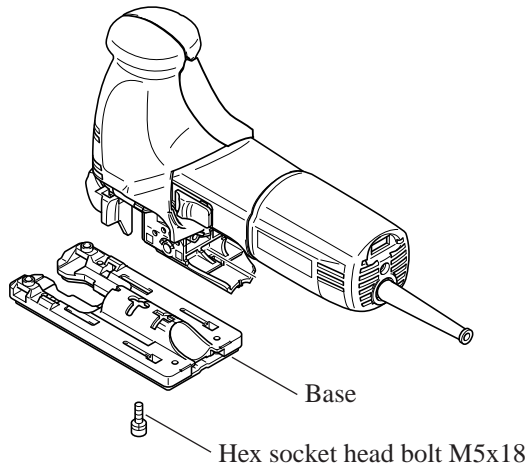

Fig. 1

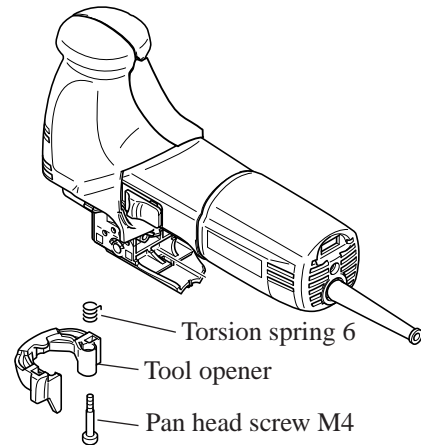

Fig. 1A

< 3 > Assembling tool opener

1. Put torsion spring 6 into tool opener. And fasten tool opener with pan head screw M4. See Fig. 1A above.
2. Bring the tail of torsion spring 6 which is extruding from tool opener, to the original position by turning it clockwise. See Fig. 2.

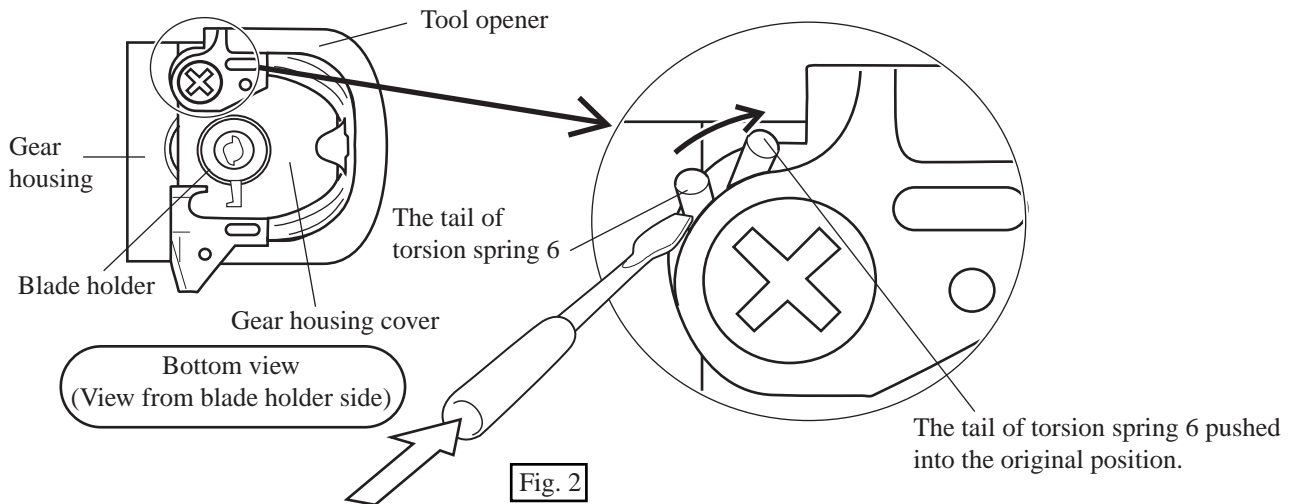

Fig. 2

< 4 > Disassembling head cover section (Model 4341T / 4341CT / 4341FCT)

1. Separate head cover R from head cover L by unscrewing the following screws. See Fig. 3.

- 2 pcs. of tapping screws 4x40,
- 1 pc. of tapping screw M4x50

< Note in disassembling >

Head covers R and L have spikes respectively for fixing on motor housing. Be careful, not to break them, when disassembling.

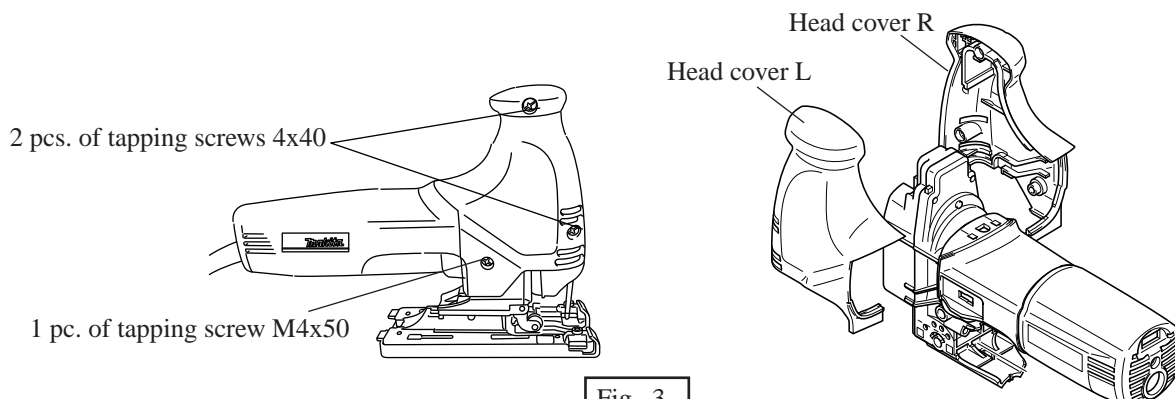

Fig. 3

< 5 > Disassembling gear housing cover section

1. After taking off safety wire from gear housing cover, unscrew 4 pcs. of tapping screws CT 4 x 16. Then, gear housing cover can be separated from gear housing. See Fig. 4.

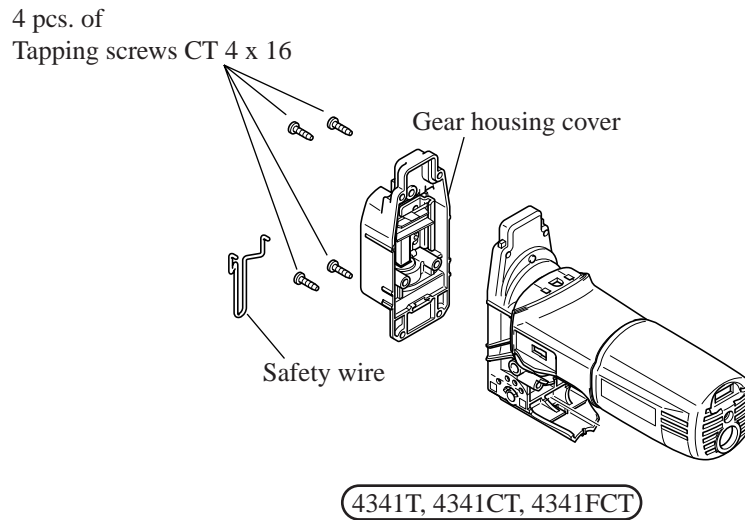
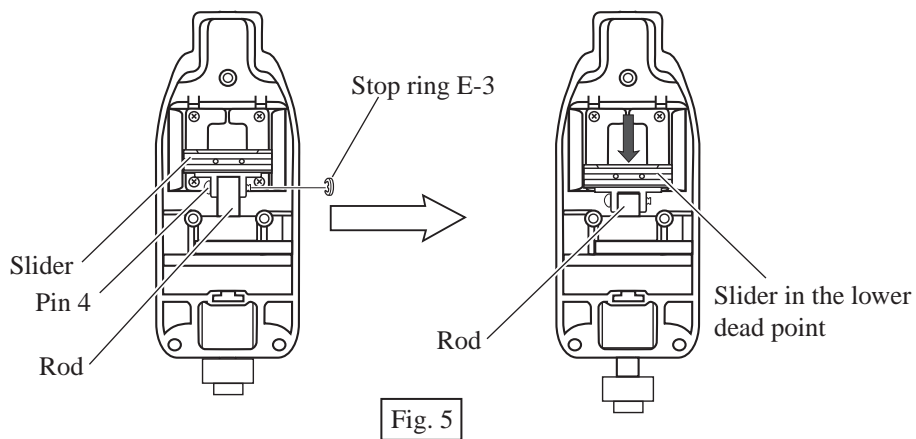

Fig. 4

2. Take off stop ring E-3 with small flat head screwdriver. And push slider to the lower dead point. See Fig. 5.



3. Slide pin 4 in order to disconnect rod with slider. And then, pull out rod from gear housing cover.

Disassemble linear guides by unscrewing 4 pcs. of pan head screws M4 x 10. So, leaf spring, pin 4 and slider can be disassembled from gear housing cover. See Fig. 6.

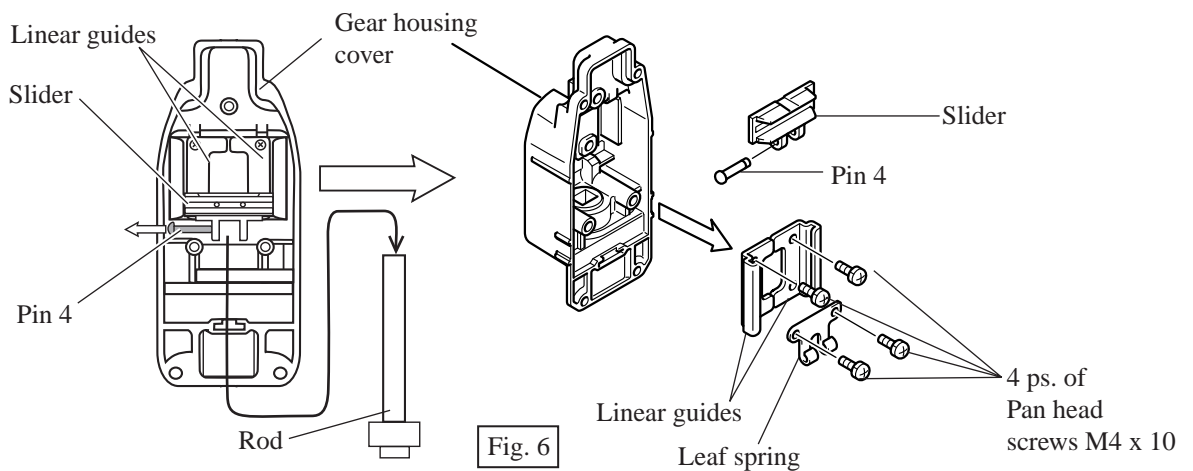

< 6 > Assembling gear housing cover section

1. Assemble tool opener to gear housing cover with referring to Fig. 1A and Fig. 2 at page 3.
2. Put leaf spring in gear housing cover, paying attention to its assembling direction as illustrated in Fig. 7. And insert rod into gear housing cover, paying attention to the direction of hook of blade holder as illustrated in Fig. 7A.

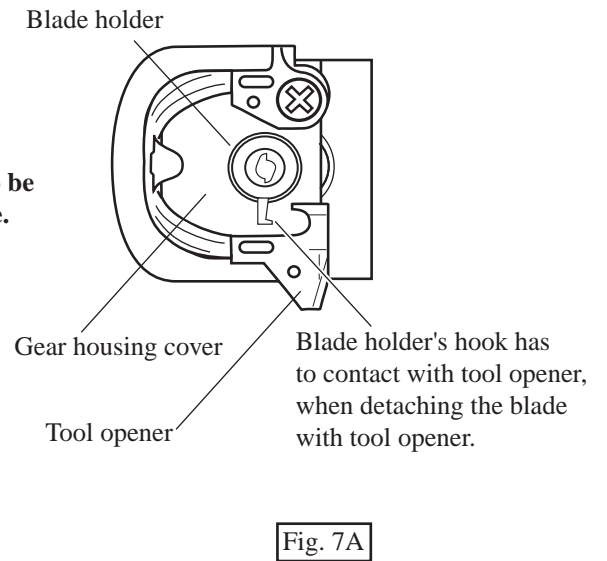
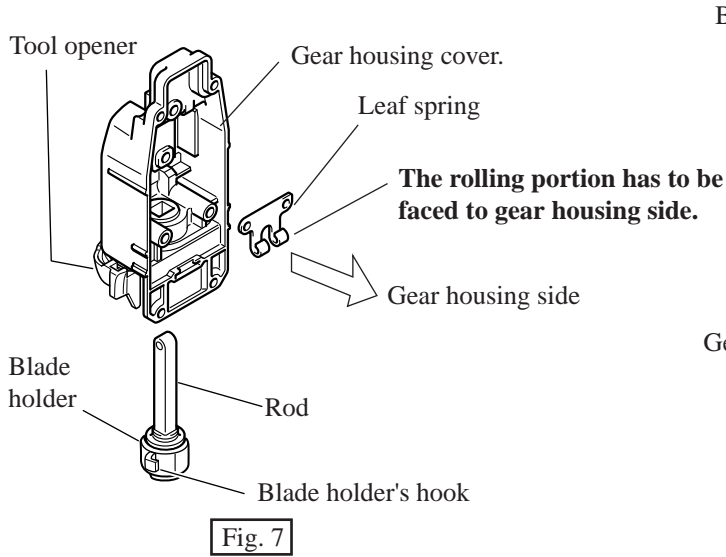

3. Align the hole of slider and the same of rod, and insert pin 4 into the aligned holes from left side as illustrated in Fig. 8. Stand slider and insert a pair of linear guide as illustrated in Fig. 8A.

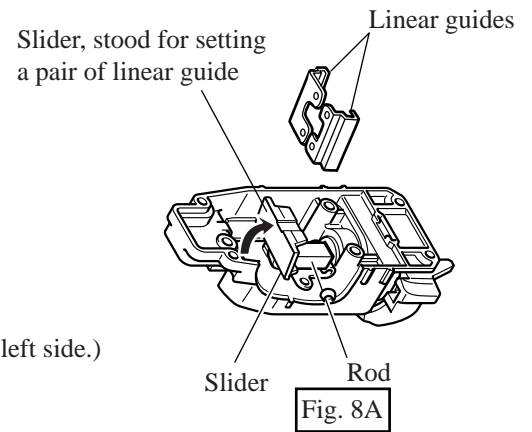
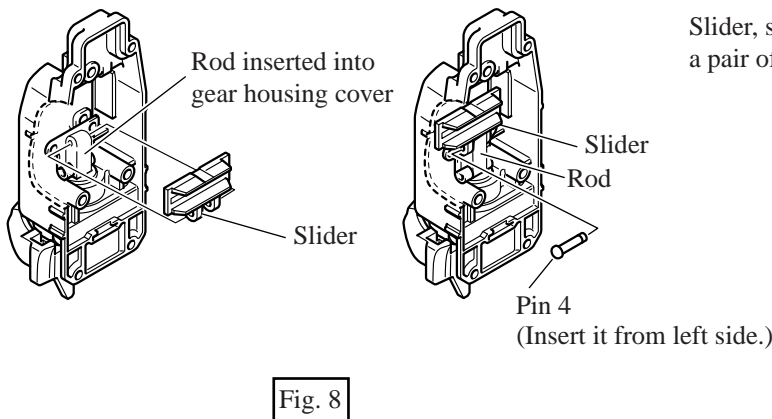

4. Lifting up leaf spring, lay a pair of linear guide in order to position leaf spring on linear guides as illustrated in Fig. 9. And push slider to the center of linear guides. Fasten linear guides with 4 pcs. of pan head screws M4 x 10 as illustrated in Fig. 9A.

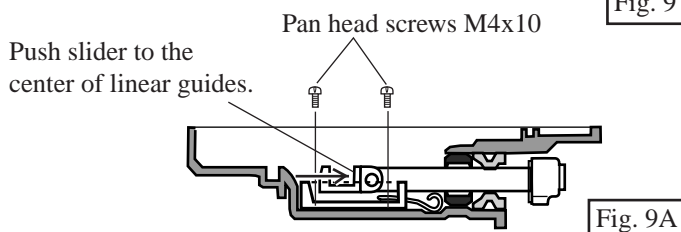
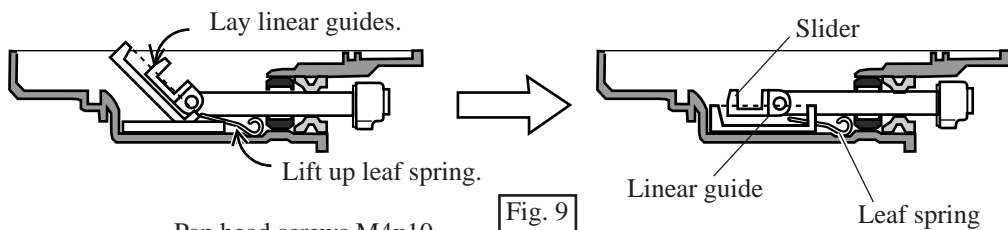

5. Assemble stop ring E-3 to pin 4 as illustrated in Fig. 10.

Check, whether slider can reciprocate on linear guide smoothly, or not.

If slider does not reciprocate smoothly, incorrectly assembled linear guides can interfere with slider in reciprocating. Try again to assemble linear guides correctly.

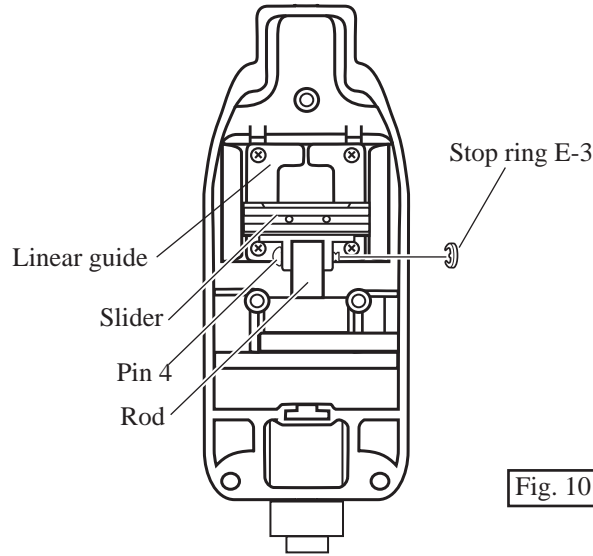

Fig. 10

6. Lubricate the parts assembled in gear housing cover with referring to "< 1 > Lubrication " at page 2.

7. Aligning slider to needle bearing 407 on crank complete, assemble gear housing cover section to gear housing as illustrated in Fig. 11. Do not forget to assemble packing between gear housing cover and gear housing. See Fig. 11A.

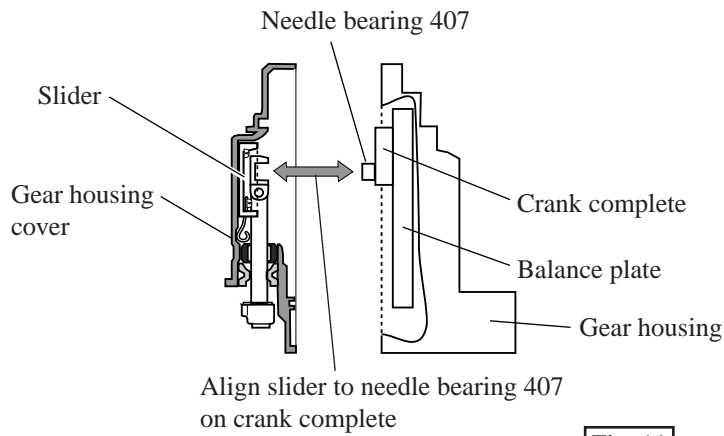

Fig. 11

4 pcs. of
Tapping screws CT 4 x 16

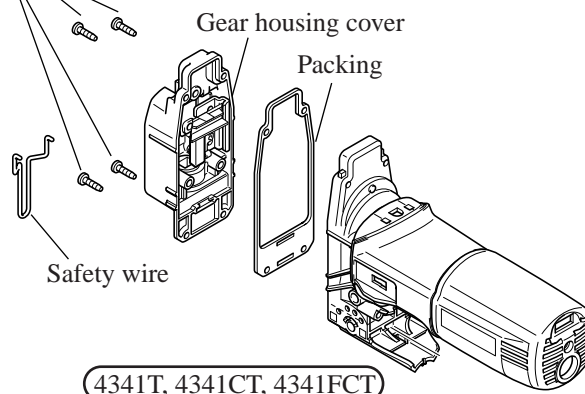

Fig. 11A

< 7 > Disassembling blade holder

1. Disassemble rod with referring to "< 5 > Disassembling gear housing cover section" at page 4.
2. Disassemble dust cover, and then disassemble retaining ring R-18. as illustrated in Fig. 12.
So, blade holder and torsion spring 15 can be separated from rod as illustrated in Fig. 12A.

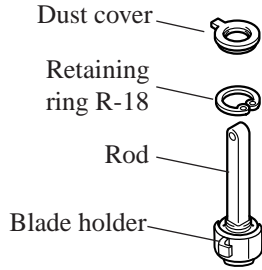

Fig. 12

Be careful, not to lose push pin, when disassembling.

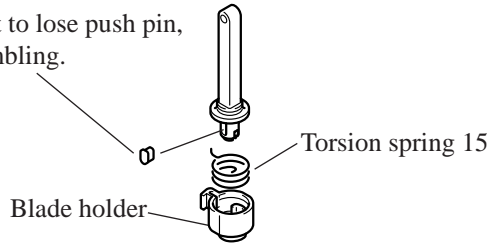

Fig. 12A

< 8 > Assembling blade holder

1. Apply MAKITA grease FA No.2 to push pin and set it in the hole of rod. And assemble torsion spring 15 to rod by inserting its tail shown in Fig. 13 into the hole of rod.
2. Set blade holder to rod as illustrated in Fig. 14. And bring the tail of torsion spring 15 to the space A of blade holder as illustrated in Fig. 15.

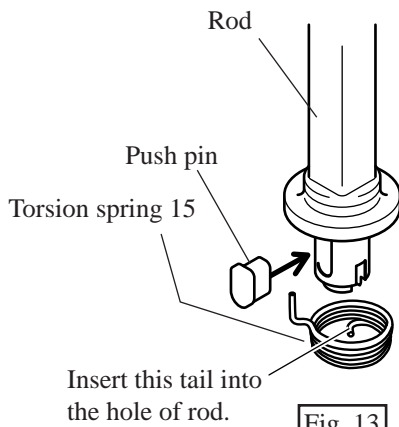

Fig. 13

Aligning the mark of blade holder and push pin, set blade holder to rod.

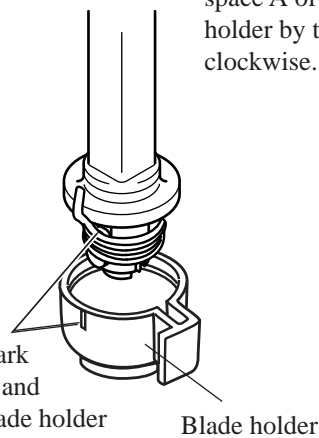

Fig. 14

Bring this tail to the space A of blade holder by turning clockwise.

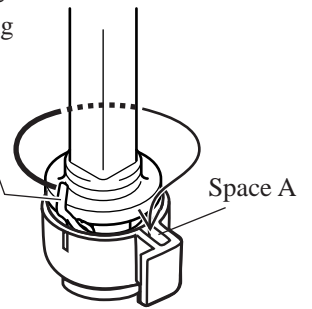

Fig. 15

3. Push rod into blade holder, and assemble retaining ring R-18 to the groove in blade holder as illustrated in Fig. 16.
4. Assemble dust cover as illustrated in Fig.17.

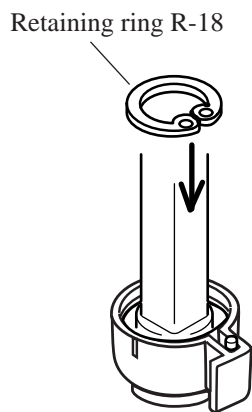

Fig. 16

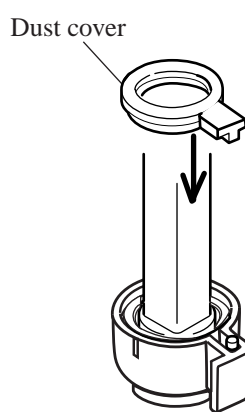
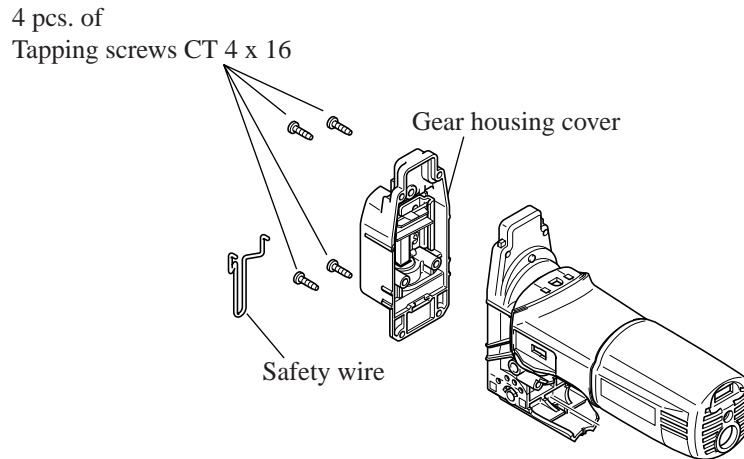

Fig.17

< 9 >Disassembling parts in gear housing

1. After taking off safety wire from gear housing cover, unscrew 4 pcs. of tapping screws CT 4 x 16. Separate gear housing cover from gear housing. See Fig. 18.



4341T, 4341CT, 4341FCT

Fig. 18

2. Locking crank complete with something bar-formed metal, unscrew 2 pcs. of hex socket head bolts M4 x 12 as illustrated in Fig.19.

No.1R235
Round bar for arbor

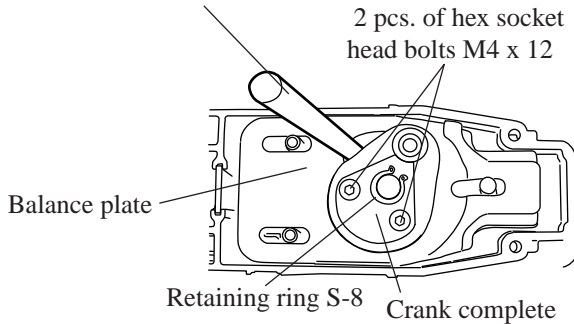

Fig.19

< Note in disassembling >

2 pcs. of hex socket head bolts M4 x 12 are adhesive bolts. It is recommended to unscrew them with impact driver.

3. Disassemble retaining S-8. Then, the inner parts can be disassembled from gear housing as illustrated in Fig.20.

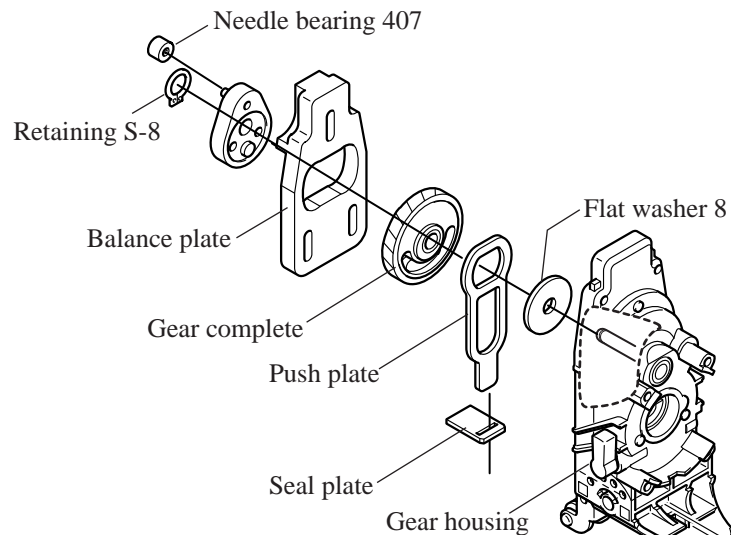

Fig.20

<10 > Assembling parts in gear housing

1. Assemble flat washer 8 to the shaft in gear housing. See Fig. 21.
2. After assembling seal plate to push plate, assemble them to the shaft in gear housing. See Fig. 22.
3. Lubricate the parts with referring to " < 1 > Lubrication " at page 2.
4. Assemble gear complete and balance plate to the shaft in gear housing. See Fig. 23.
5. Assemble crank complete to gear housing. With turning crank complete, press it down to the position in which you can see the shaft's groove for retaining ring S-8. See Fig. 24.
6. Lock crank complete with something like 1R235 "round bar for arbor", and fasten crank complete with 2 pcs. of hex socket head bolts M4 x 12 with adhesive. See Fig. 25.

< Note >

Do not fasten with the used hex socket head bolts M4 x 12. The fresh adhesive hex socket head bolts M4 x 12 have to be used. The fastening torque of these bolts is 2.4 - 3.5 N.m.

7. Assemble retaining ring S-8 to the shaft of gear housing. See Fig. 26.

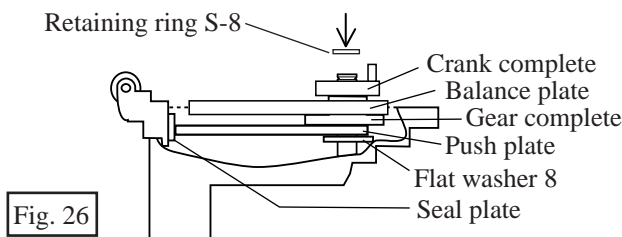
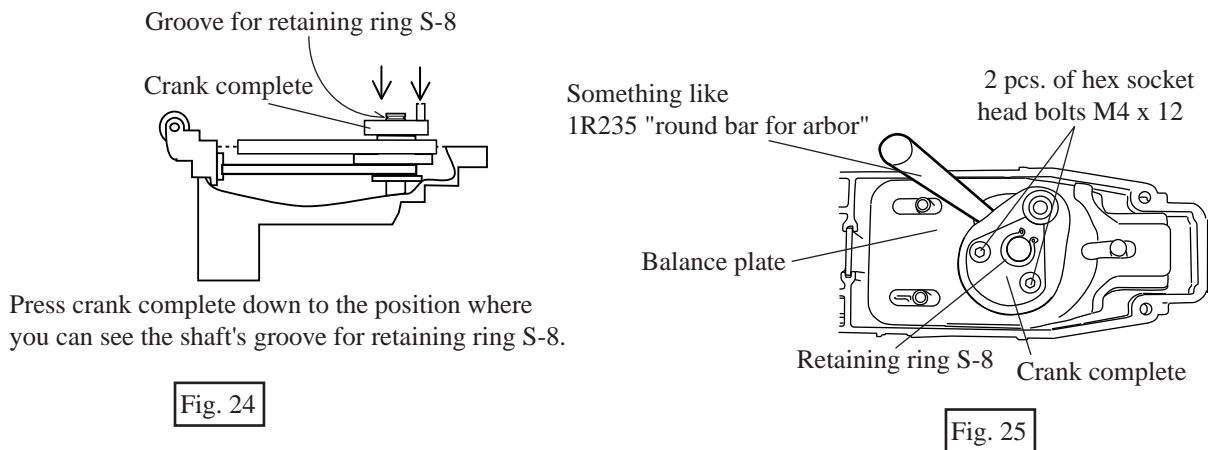
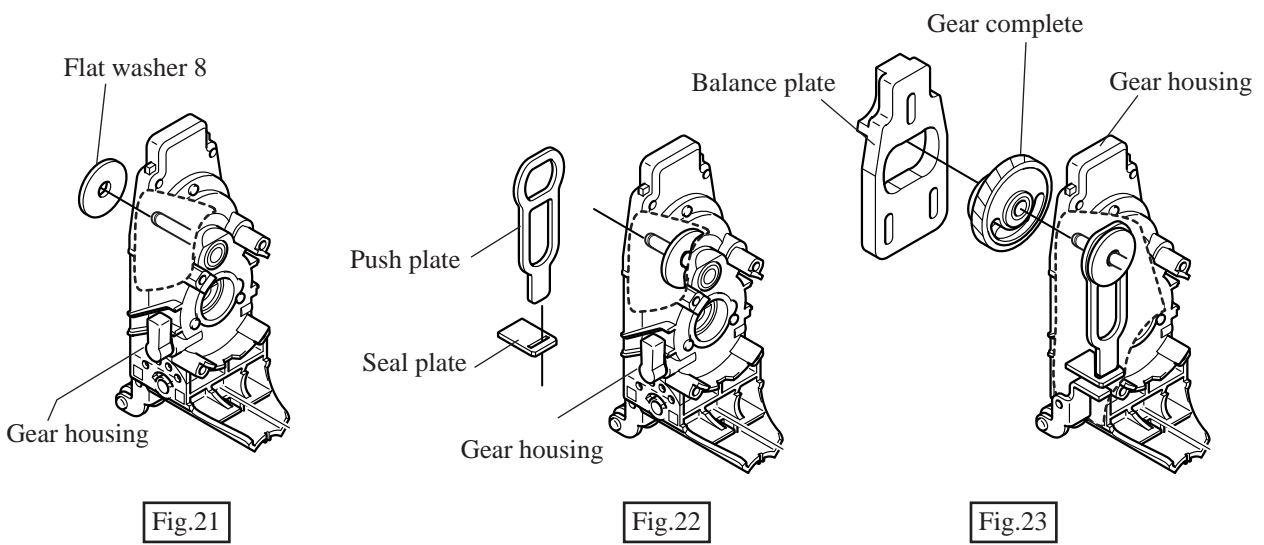

< 11 > Disassembling armature (4341T, 4341CT, 4341FCT)

1. With referring to the following section, disassemble head cover L and R, and gear housing cover.

"< 4 > Disassembling head cover section" at page 3

"< 5 > Disassembling gear housing cover section" at page 4

2. Disassemble rear cover by unscrewing tapping screw 4 x 18. And then, disassemble carbon brushes. See Fig. 31

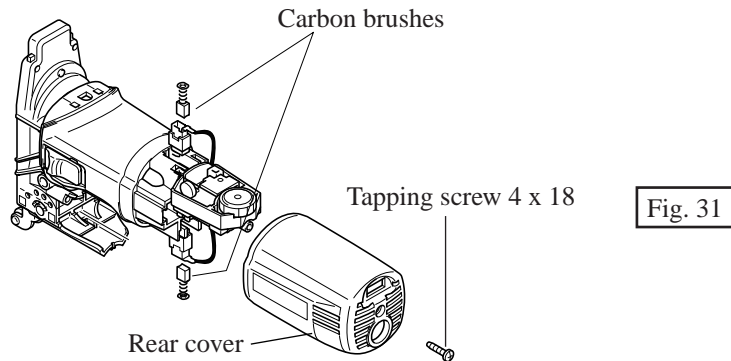

3. Disassemble retaining ring S-8, and separate crank complete, balance plate and gear complete from the shaft of gear housing as illustrated in Fig. 32.

< Note in disassembling >

* No need to disassembling hex socket head bolt M4 x 12, crank complete and gear complete from balance plate.

* Be careful, not to lose needle bearing 407.

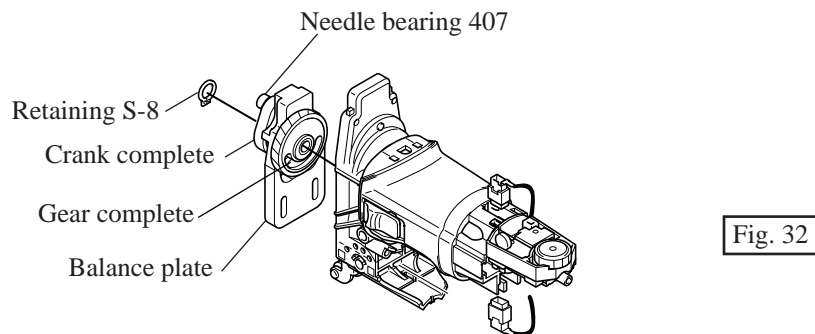

4. Unscrew 4 pcs. of tapping screws M4 x 30, and separate gear housing from motor housing. Separate armature from gear housing as illustrated in Fig. 33.

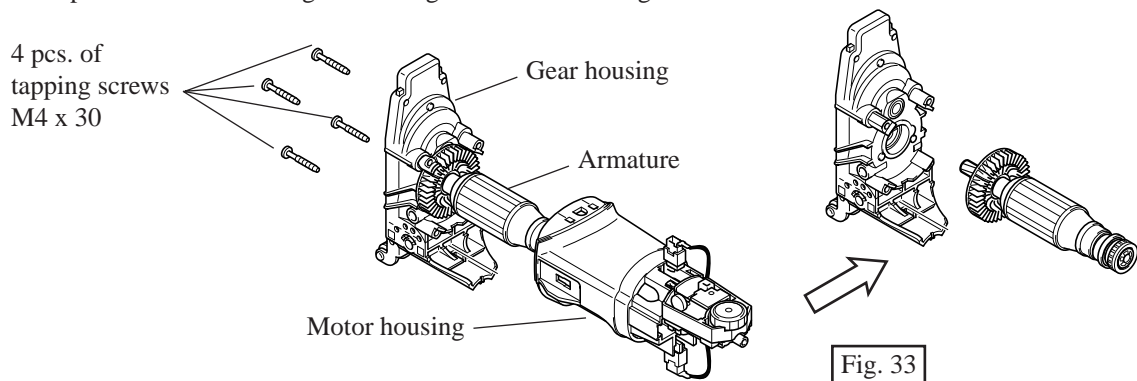

5. Disassemble self lock with small flat head screwdriver. Then, magnet sleeve, wave washer 6 and rubber ring 19 can be disassembled from armature shaft as illustrated in Fig. 34.

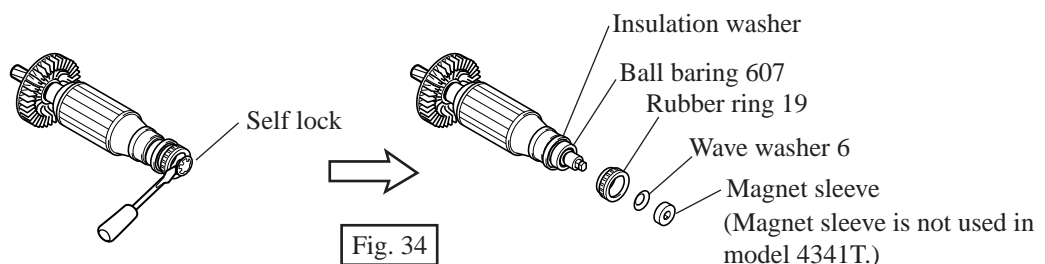

6. Disassemble ball bearing 607 LLB from armature shaft as illustrated in Fig. 35.

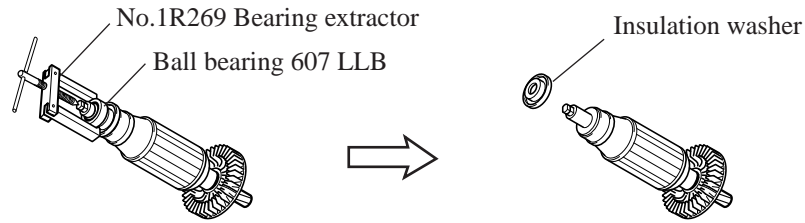

Fig. 35

< 12 > Assembling armature

< Note in assembling >

1. Do not assemble the used self lock. The self lock has to be always replaced with the fresh one.
2. Pay attention to the assembling direction of self lock and wave washer 6. See Fig. 36
3. The magnet sleeve is installed to the armature shaft on commutator side for sensing the variation of rotating speed. If it would be damaged, the electronic speed control does not work any more.
So, applying 1R026 " Bearing setting pipe" to self lock, press it with your hand, instead of with arbor press.

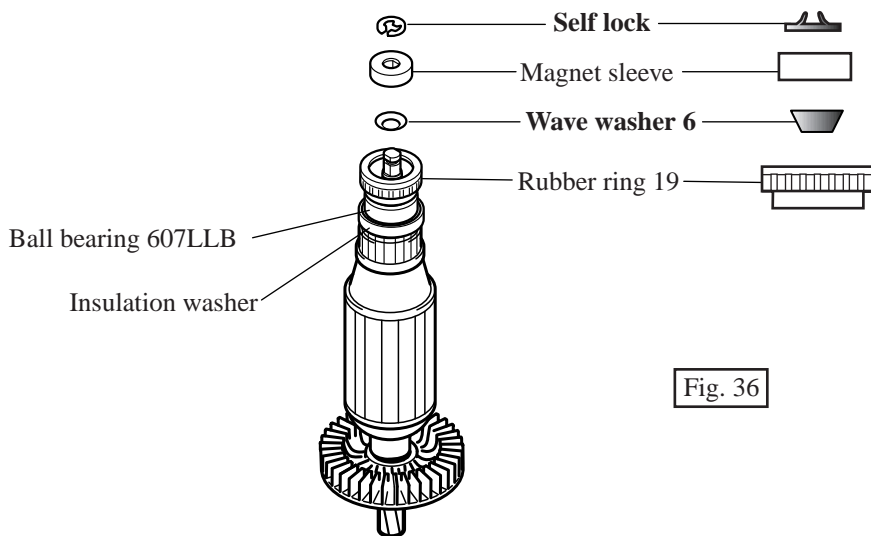

Fig. 36

< 13 > Disassembling lever 17 (for orbital action mode change)

1. With referring to the following section, head cover L and R, and gear housing cover.

"< 4 > Disassembling head cover section section" at page 3"

"< 5 > Disassembling gear housing cover section" at page 4

2. Disassemble stop ring E-5 from the shaft portion of lever 17 with small flat head screwdriver. See Fig. 37.
3. Aligning lever 17 with indication " III ", pull out it from gear housing. Then, cap 5 and compression spring 3 are disassembled. See Fig. 37A.

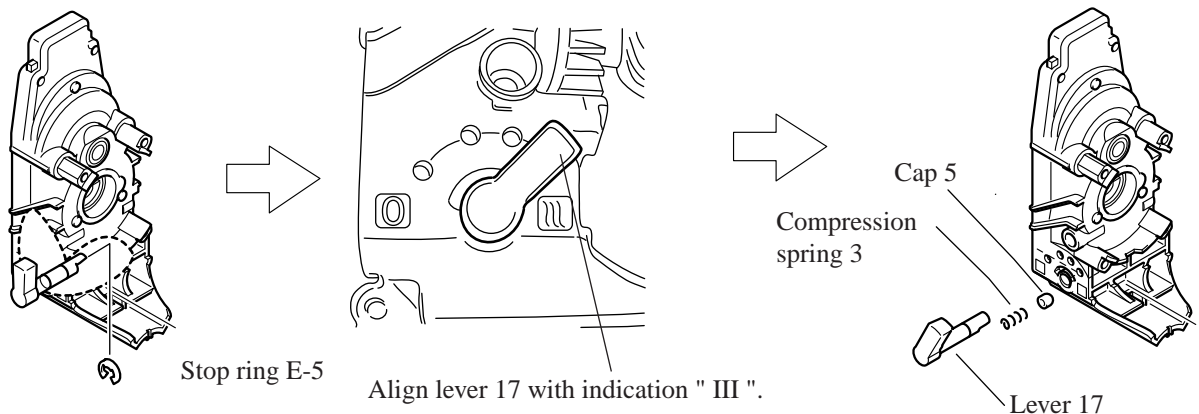

Fig. 37

Fig. 37A

< 14 > Disassembling switch rod (4341T, 4341CT, 4341FCT)

1. With referring to "< 11 > Disassembling armature (4341T, 4341CT, 4341FCT)" at page 10, disassemble rear cover.
2. Disassemble the following parts from motor housing. See Fig. 38.

Model No.	Parts to be disassembled
4341FCT	LED circuit, Switch, Switch block unit, Controller
4341CT	Switch, Switch block unit, Controller
4341T	Switch, Switch block unit,

3. Disconnect switch rod from switch lever by pulling. Then, switch rod can be disassembled from motor housing. See Fig. 39.

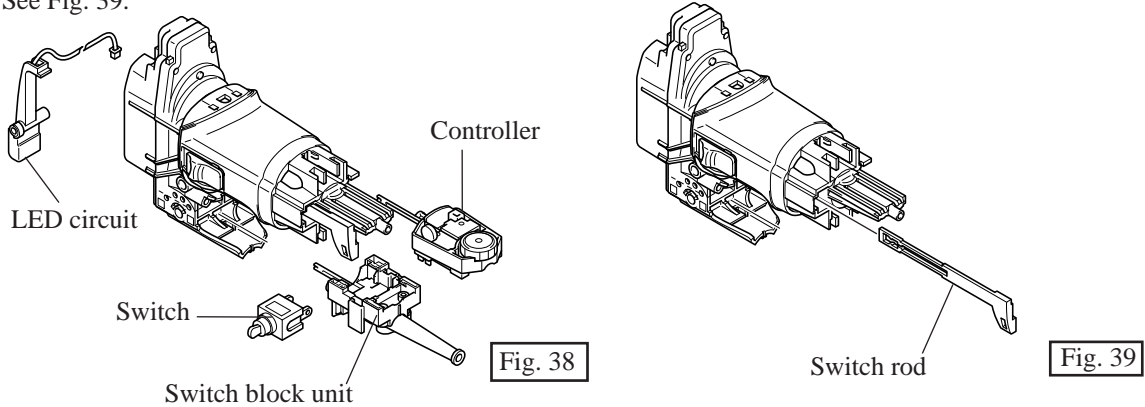

< 15 > Assembling switch rod

1. Insert switch rod into motor housing and align the wide square hole of switch rod with the wide square hole of motor housing. See Fig. 40 and Fig. 40A.
2. Pressing the switch rod to the wall of motor housing, insert switch lever into the aligned wide square holes as illustrated in Fig. 38A.
3. Pushing the switch rod to the gear housing side, interlock switch lever with switch rod.

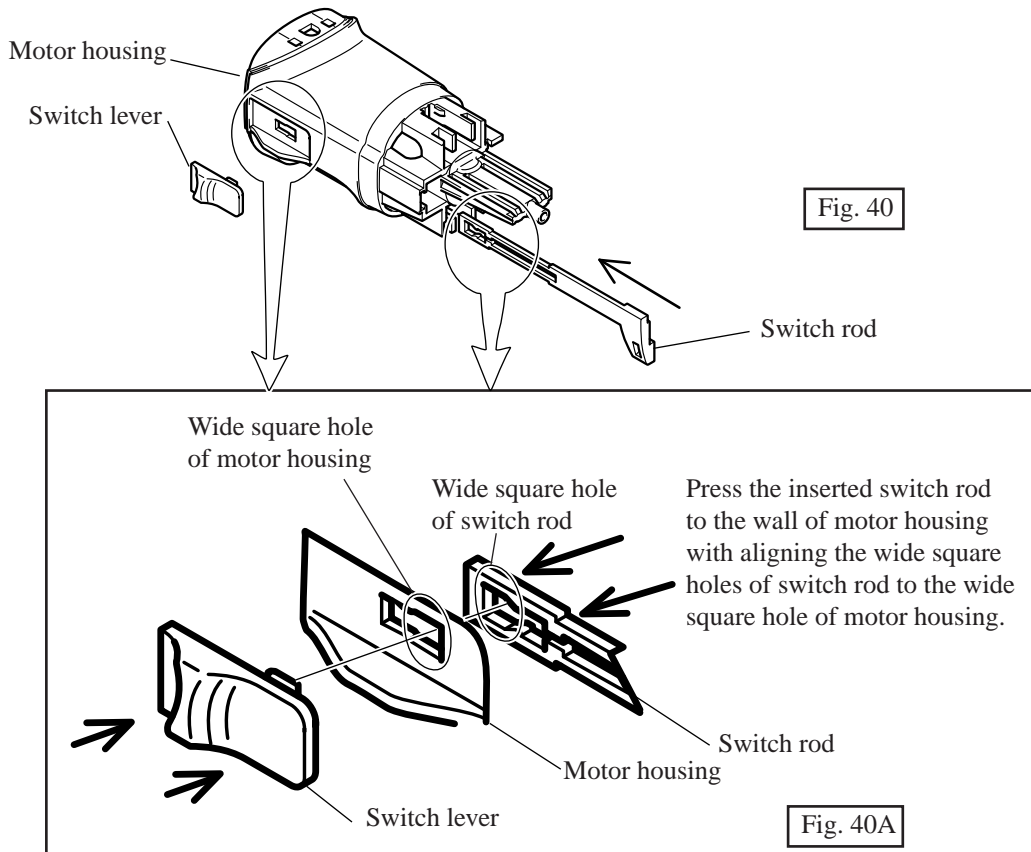

4. Connect lead wire from LED circuit to controller.

► **Circuit diagram in the rear of motor housing**

4341CT (with controller, without LED jog light)

4341FCT (with controller and LED job light)

The electrical parts in Model 4341T series models are connected with terminals each other, in stead of with lead wires.

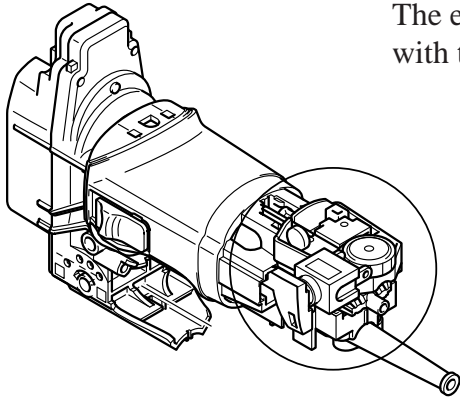

----- : Connecting with terminal

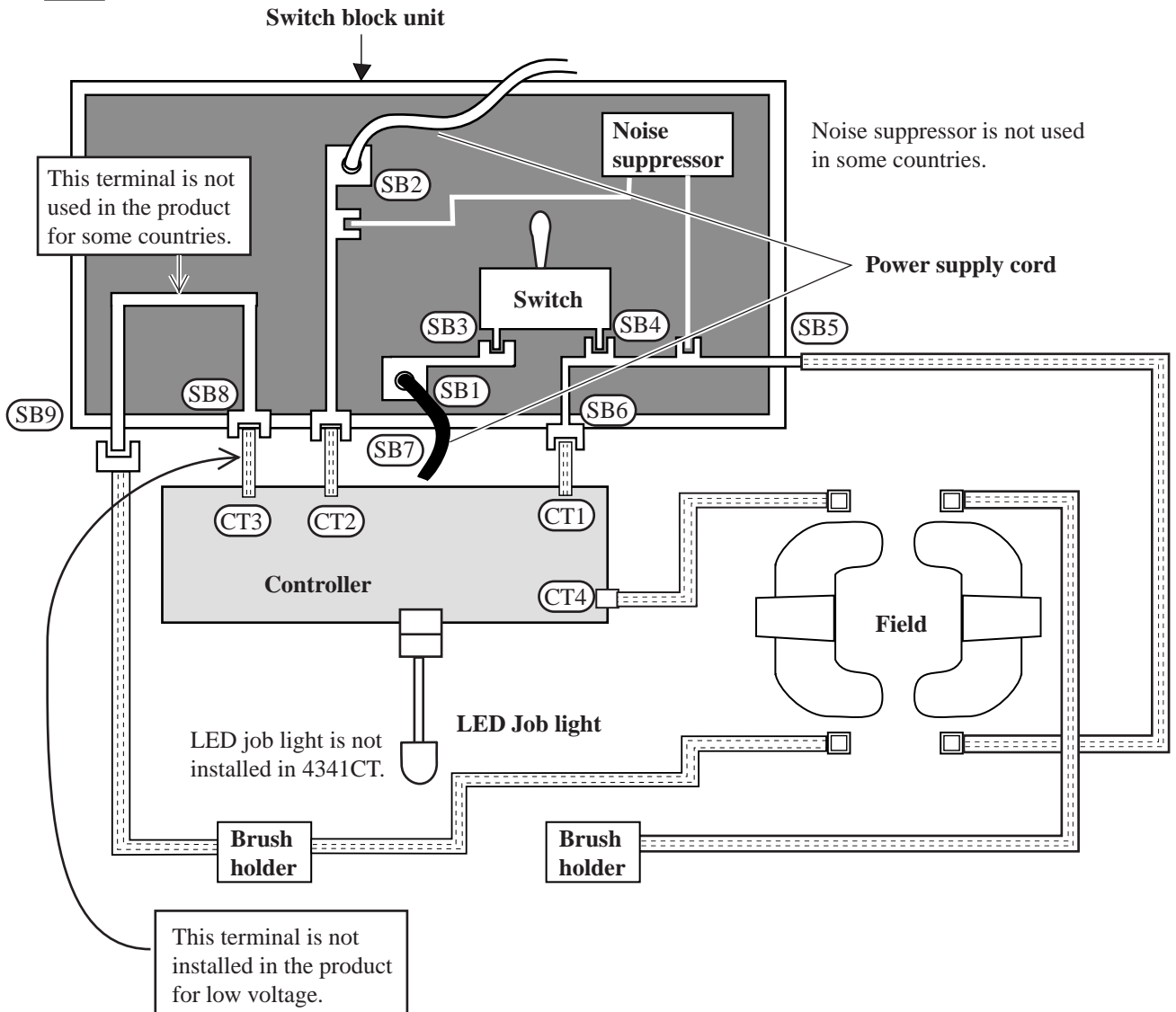

▶ Circuit diagram in the rear of motor housing

4341T (without controller and LED jog light)

The electrical parts in Model 4341T series models are connected with terminals each other, in stead of with lead wires.

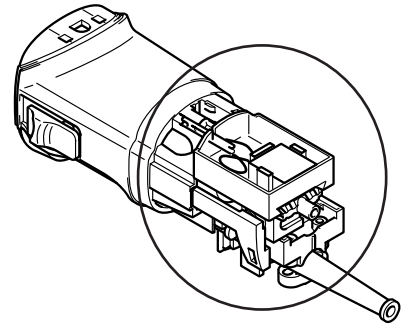
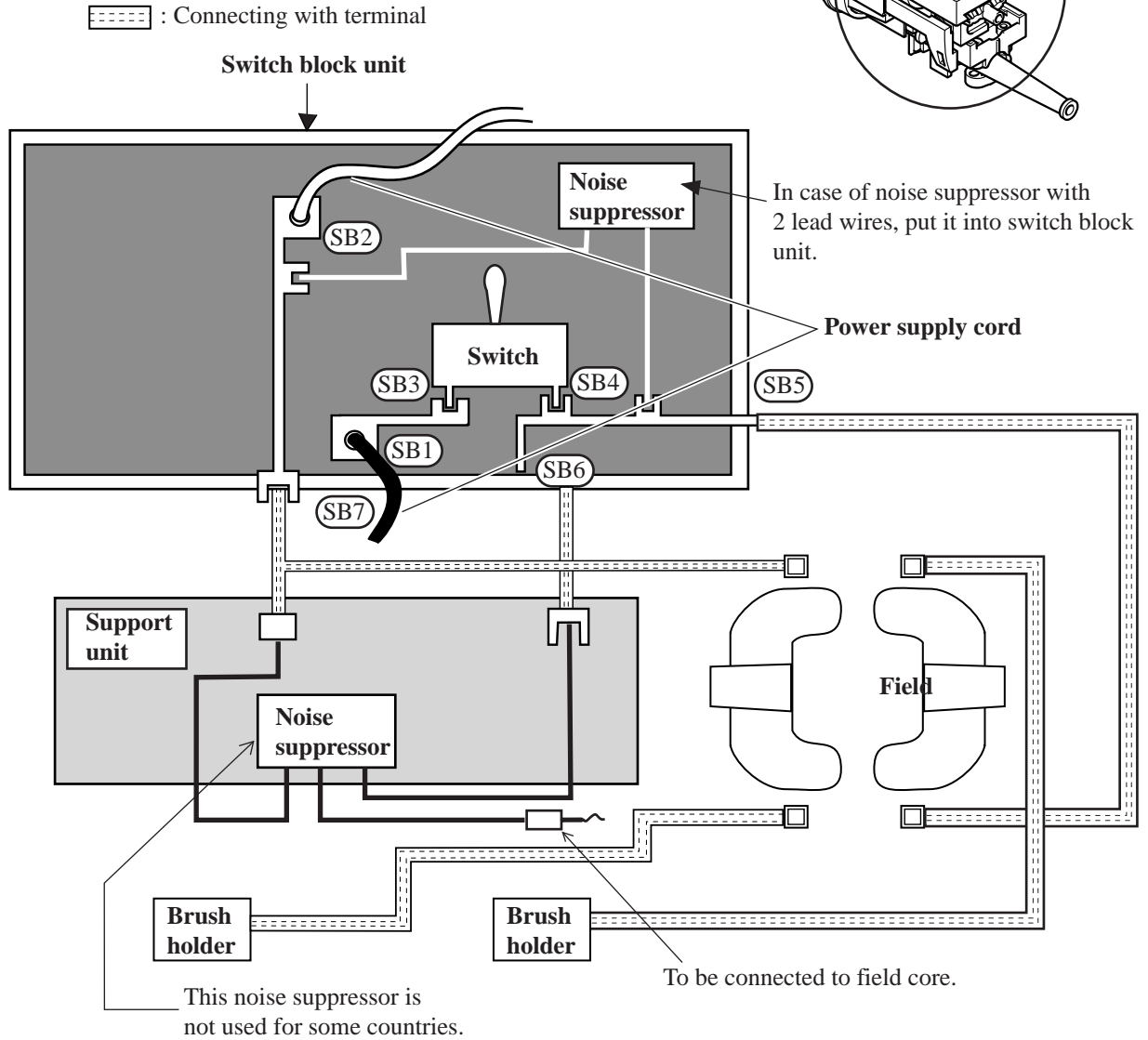

▶ Wiring diagram

4341T (without controller and LED jog light)

