

TECHNICAL INFORMATION



PRODUCT

P 1 /15

Model No. ▶ 4351T, 4351CT, 4351FCT

Description ▶ Jig Saw

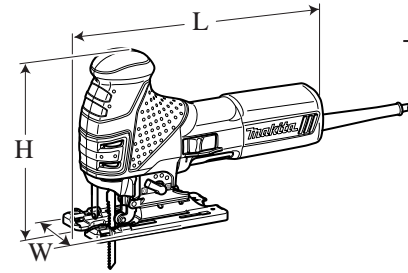

CONCEPT AND MAIN APPLICATIONS

Models 4351T, 4351CT and 4351FCT have been developed as the successor models of 4341T series models. In addition to the advantages of the predecessor models, feature new exterior design with ergonomic rubberized handle.

Top handle type models are also available as 4350T series models.

Dimensions: mm (")	
Length (L)	271 (10-11/16)
Width (W)	73 (2-7/8)
Height (H)	187 (7-3/8)

► Specification

4351T

Voltage (V)	Current (A)	Cycle (Hz)	Continuous Rating (W)		Max. Output (W)
			Input	Output	
110	5.6	50/60	580	300	550
120	5.1	50/60	---	300	550
220	2.8	50/60	580	300	550
230	2.7	50/60	580	300	550
240	2.5	50/60	580	300	550

4351CT/ 4351FCT

110	6.9	50/60	720	320	700
120	6.3	50/60	---	320	700
220	3.4	50/60	720	320	700
230	3.3	50/60	720	320	700
240	3.2	50/60	720	320	700

Specification		Model	4351T	4351CT	4351FCT
No load speed: strokes per min.			2,800	800 - 2,800	
Length of stroke: mm (")			26 (1)		
Shank type			B-type		
Capacities: mm (")	Wood*1		135 (5-5/16)		
	Steel		10 (3/8)		
	Aluminum		20 (25/32)		
Cut settings			3 Orbital settings + Straight cutting		
Toolless blade change			Yes (Push-in-lock system)		
Electronic control	Variable speed control by dial		No	Yes	
	Soft start		No	Yes	
	Constant speed control		No	Yes	
LED Job light			No	No	Yes
Protection against electric shock			Double insulation		
Power supply cord: m (ft)			2.5 (8.2)*2		
Net weight: kg (lbs)			2.4 (5.3)	2.5 (5.5)	

*1 when cutting with optional blade No.B-16L *2 Australia, New Zealand: 2.0m (6.6ft)

► Standard equipment

Jig saw blade B-10	2	Cover plate	1	Plastic carrying case	1
Jig saw blade BR-13	2	Anti-splintering device	1	Dust nozzle*3	1
Jig saw blade B-22	2	Hex wrench 4	1	*3 for European countries only	

Note: The standard equipment for the tool shown above may differ from country to country.

► Optional accessories

Jig saw blades No.51, 58, 59, B-8, B-10 to B-19, B-21 to B-27, B-16L, BR-13
 Guide rule, Guide rail, Guide rail adaptor, Anti-splintering device
 Hose complete 28-5, Dust nozzle

► **Repair**

CAUTION: Unplug the tool and remove the jig saw blade for the safety before maintenance !

Code No.	Description	Use for
1R026	Bearing setting pipe 16-8.2	Inserting Self lock 6
1R235	Round bar for arbor 6-100	Securing Crank
1R291	Retaining ring S and R pliers	Removing/ Installing Retaining ring S-8 in Crank housing
1R311	Retaining ring pliers with long bent nails	Removing/ Installing Retaining ring R-18
1R014	1/4" Hex. shank bit M4 for Hex. socket head bolt	Fastening M4x12 Hex. socket head bolts
1R220	Ratchet head 9.5 (for 1R219)	
1R222	Socket adapter (for 1R219)	
1R228	1/4" Hex.shank bit for M4	
1R254	Torque wrench shaft 2-6N.m	
134873-0	Bit adapter ass'y	
1R269	Bearing extractor	Replacing Ball bearings

< 1 > Lubrication

Apply Makita grease FA. No.2 to the portions marked with black triangle, and machine oil No.120 to the portions marked with gray triangle to protect parts and product from unusual abrasion.

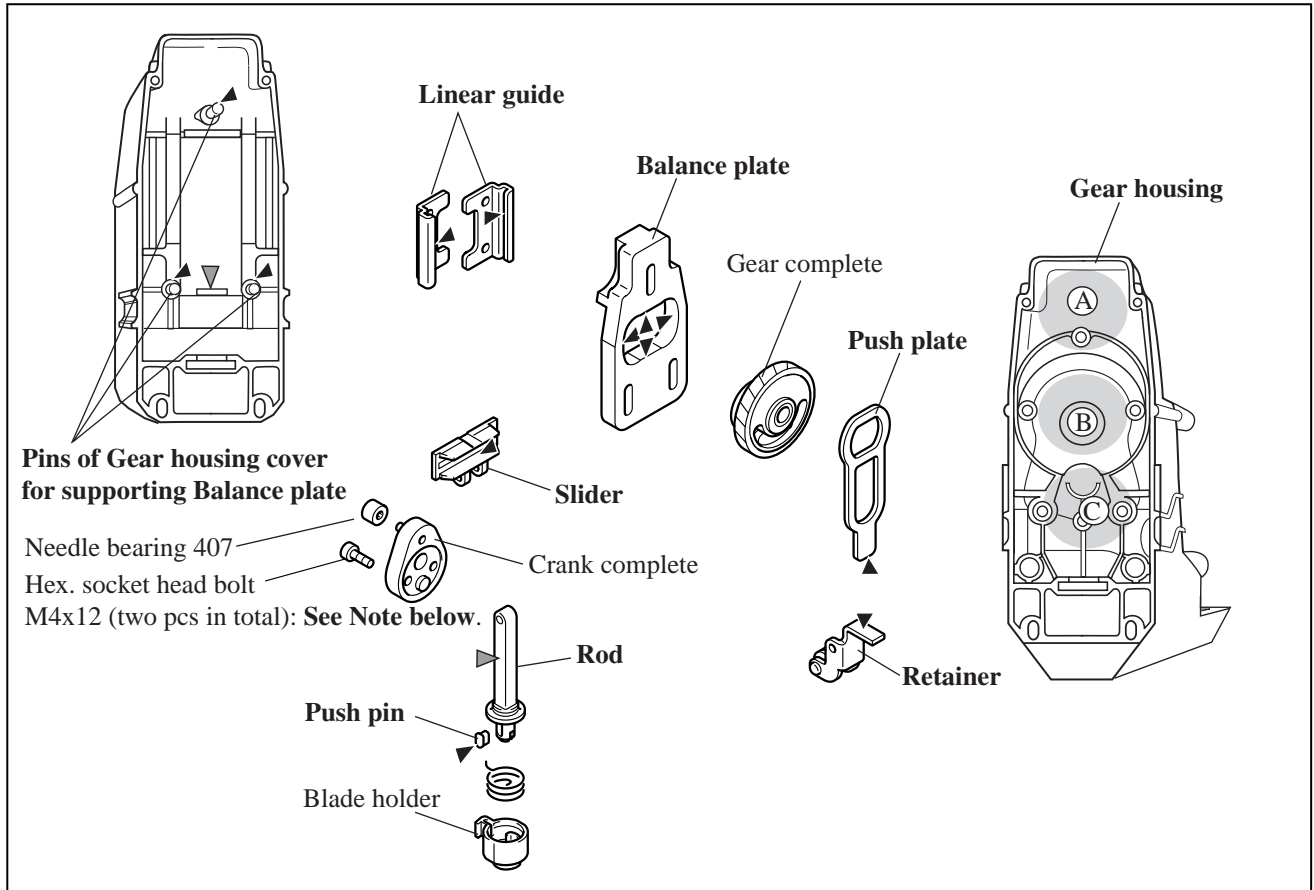

Item (Code No.)	Description	Portion to lubricate
Makita grease FA. No.2 (042025-8A: 2.5kg)	Gear housing	The positions painted with gray
	Balance plate	The portion where contacts Gear complete.
	Gear housing cover	The pins which supports Balance plate.
	Push plate	The portion where contacts Retainer.
	Retainer	The portion where contacts Push plate.
	Linear guides	The portion where contacts Slider.
	Slider	The portion where contacts Needle bearing 407.
	Push pin	Its whole part
Machine oil No.120	Gear housing cover	The hole where Rod reciprocates.
	Rod	The portion where contacts Dust seal.

Note: When removing two M4x12 Hex. socket head bolts illustrated above, put the appropriate amount of Loctite 241/242 or ThreeBond 1321/1342 on the thread of the screws and then fasten them.

▶ Repair

[2] Disassembling Tool opener

1. Remove M5x18 Hex socket head bolt. Base is separated from product. **(Fig. 1)**
2. Remove M4 + Pan head screw. Tool opener and Torsion spring 6 are separated. **(Fig. 2)**

Fig. 1

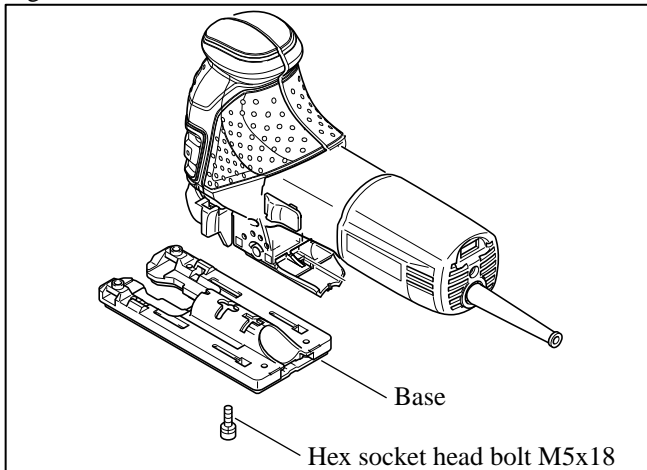
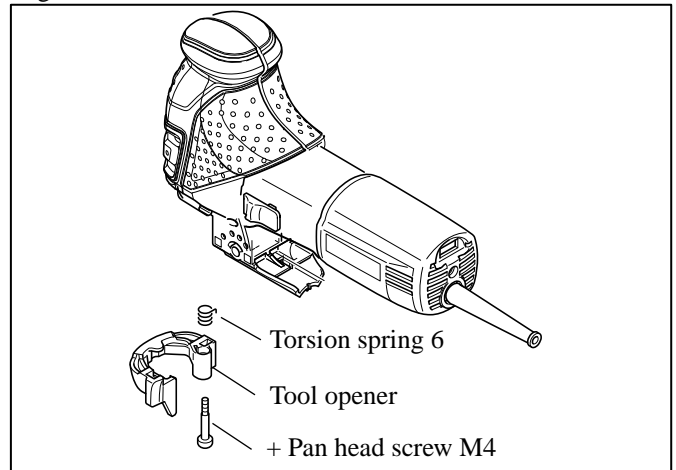

Fig. 2



[3] Assembling tool opener

1. Install Torsion spring 6 into the depression on Gear housing cover around Tool opener hinge portion, and then fasten Tool opener to Gear housing cover with M4 + Pan head screw.
2. Turn the tail of Torsion spring 6 clockwise using thin flat screwdriver to set it in place. **(Fig. 3)**

Fig. 3

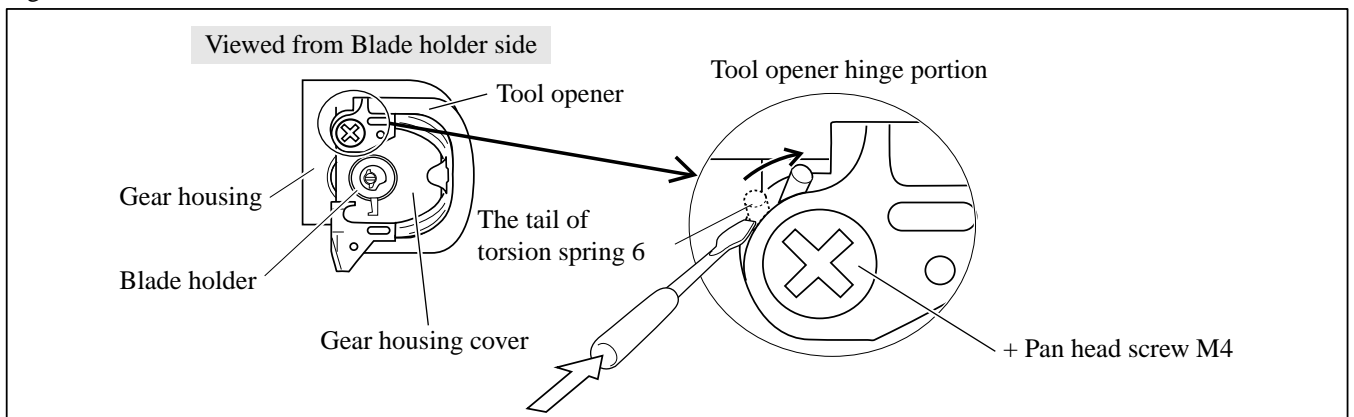

[4] Disassembling Head cover section

1. Separate Head cover R from Head cover L by the following steps.
 - (1) Removing two 4x40 Tapping screws and a 4x50 Tapping screw. **(Fig. 4)**
 - (2) Gently lift up the specific area around the hole for 4x50 Tapping screw (designated in gray color in **Fig. 4**) with slotted screwdriver in order to remove the hooks of head covers R and L from the notches of Motor housing. **(Fig. 5)**

Note: Take care not to break the hooks, the protrusion and the depressions when disassembling.

2. LED circuit (only for 4351FCT) and Safety wire can be removed together. As for removal of Safety wire, open Tool opener and remove both tails of Safety wire from the holes of Gear housing cover behind Head covers L and R.

Fig. 4

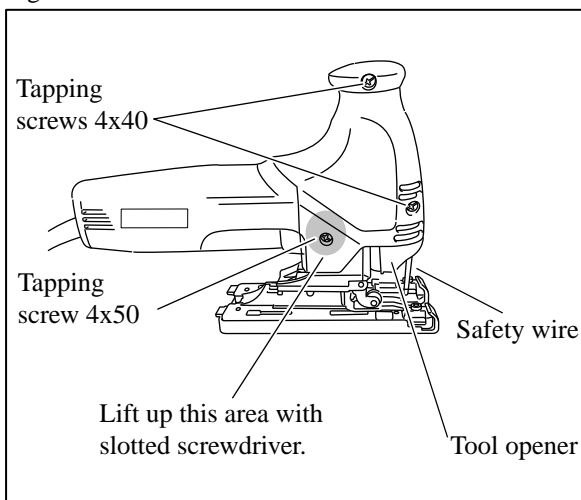
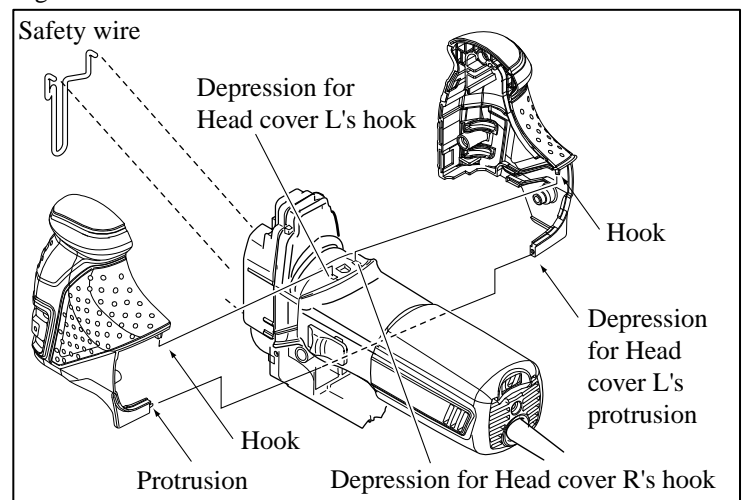

Fig. 5



► Repair

[5] Disassembling Gear housing cover section

1. After separating Safety wire from Gear housing cover, remove four 4x16 Tapping screws CT .
Gear housing cover is separated from Gear housing as illustrated in **Fig. 6**.

Fig. 6

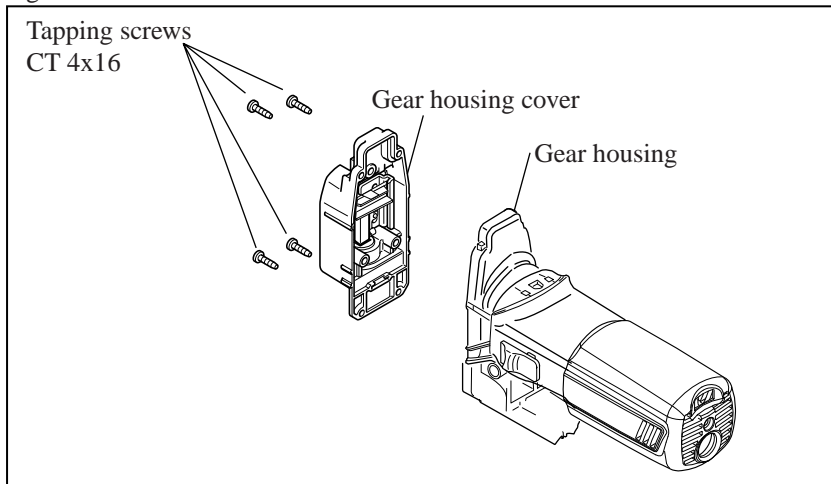

2. Remove Stop ring E-3 with slotted screwdriver.
Push Slider to the lower dead point. (**Fig. 7**)

Fig. 7

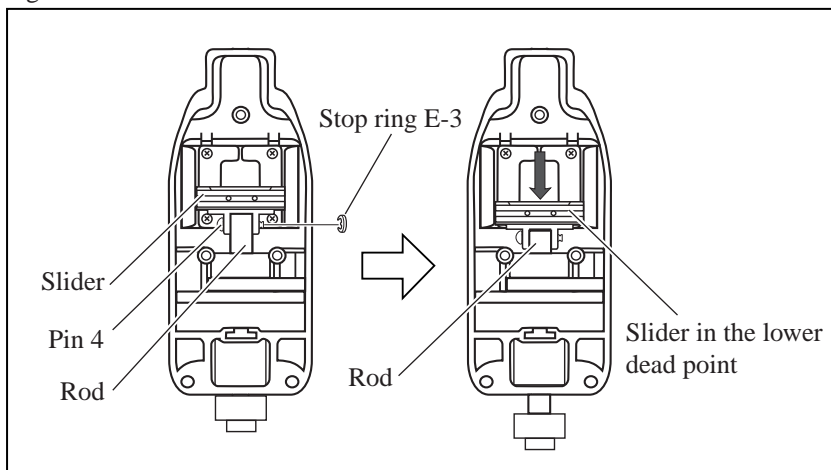

3. Slide Pin 4 in order to disconnect Rod with Slider. And then, pull out Rod from Gear housing cover.
Separate Linear guides from Gear housing by removing four M4x10 Pan head screws .
Pin 4, Slider and Leaf spring are disassembled from Gear housing cover. (**Fig. 8**)

Fig. 8

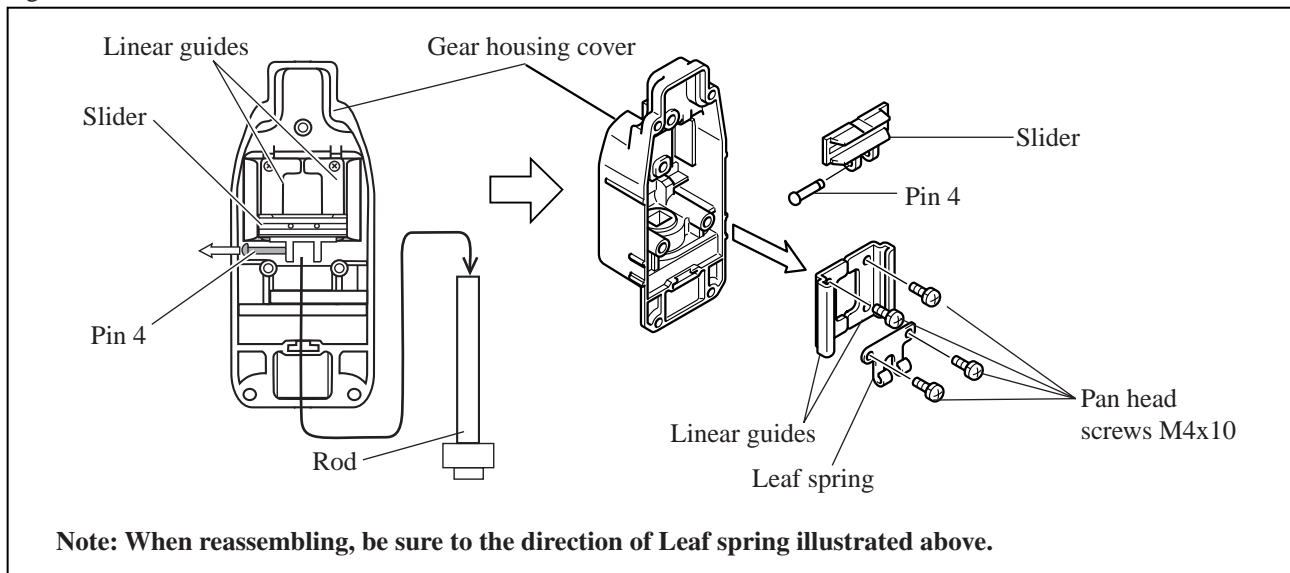

► **Repair**

[6] Assembling Gear housing cover section

1. Assemble Tool opener to Gear housing cover with referring to **Figs. 1, 2 and 3** in page 3.
2. Put Leaf spring in Gear housing cover. Pay attention to its assembling direction. (**Fig. 9**)
 Insert Rod into Gear housing cover. Pay attention to the direction of the hook of Blade holder as illustrated in **Fig. 10**.

Fig. 9

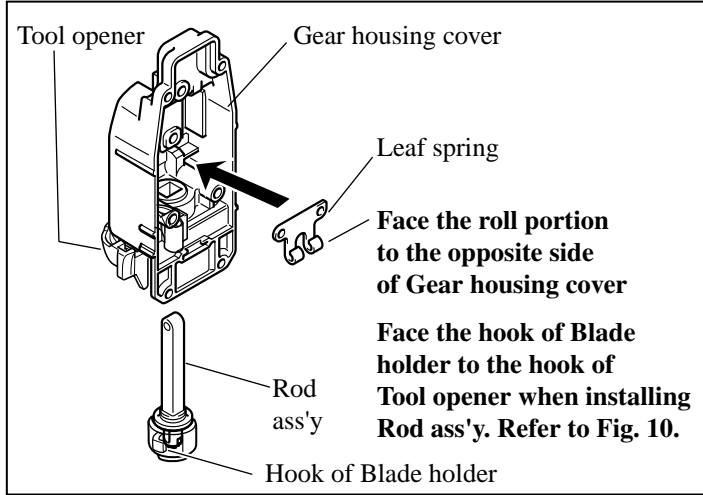
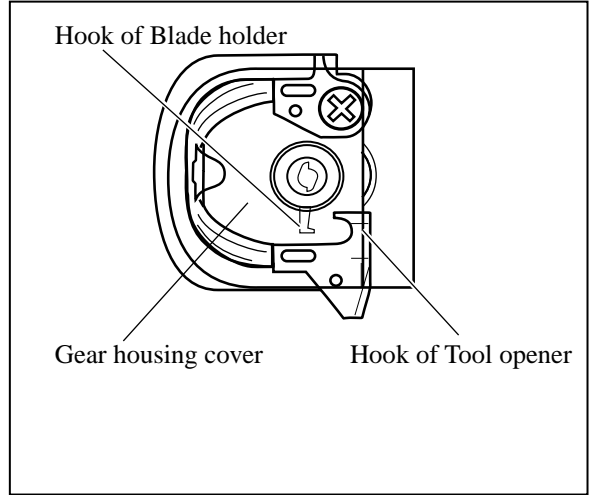

Fig. 10



3. After aligning the holes of Slider and Rod, insert Pin 4 into the aligned hole from left side as illustrated in **Fig. 11**.
4. Recline Slider fully and insert a pair of Linear guides as illustrated in **Fig. 12**.

Fig. 11

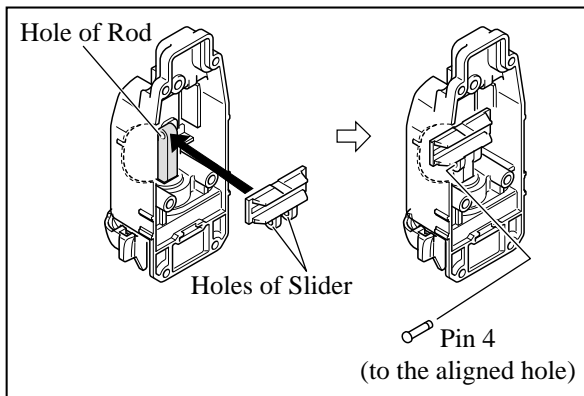
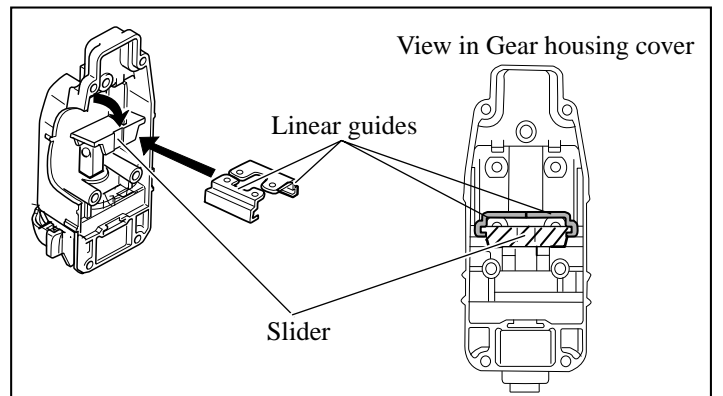

Fig. 12



5. While lifting up the flat side of Leaf spring, lay a pair of Linear guides to put the flat side of Leaf spring on Linear guides as illustrated in **Fig. 13**.
6. Move Slider to the center of Linear guides. Fasten Linear guides with four M4x10 Pan head screws as illustrated in **Fig. 14**.

Fig. 13

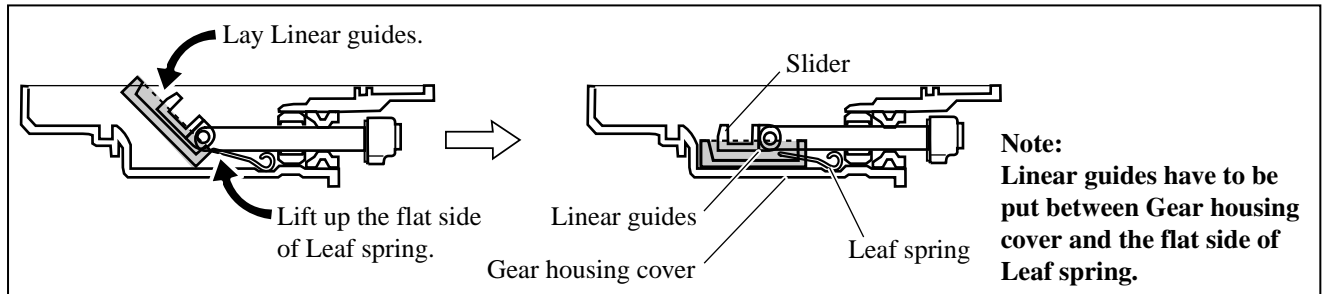
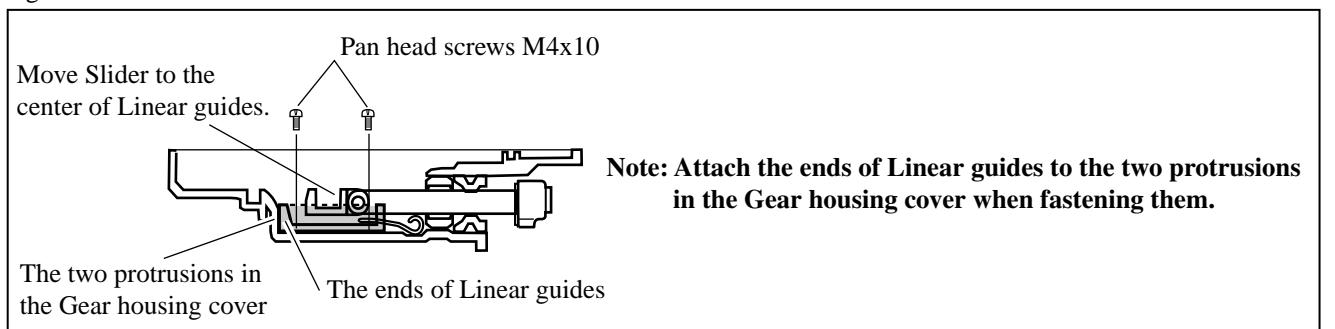

Fig. 14



► **Repair**

7. Install Stop ring E-3 to secure Pin 4 as illustrated in **Fig. 15**.
8. Check whether Slider can reciprocate on Linear guides smoothly.
Note: If Slider does not reciprocate smoothly, Linear guides may lean to the left or the right. Try again to assemble Linear guides correctly.

Fig. 15

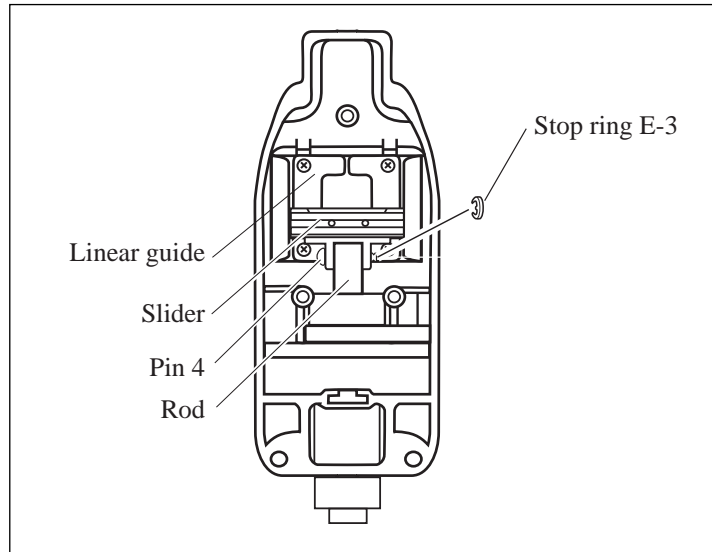

9. Lubricate the parts assembled in Gear housing cover. Refer to [1] **Lubrication** in page 2.

10. Align Slider to Needle bearing 407 on crank complete, and then assemble Gear housing cover section to Gear housing as illustrated in **Fig. 16**. Do not forget to assemble packing between Gear housing cover and Gear housing. See **Fig. 17**.

Fig. 16

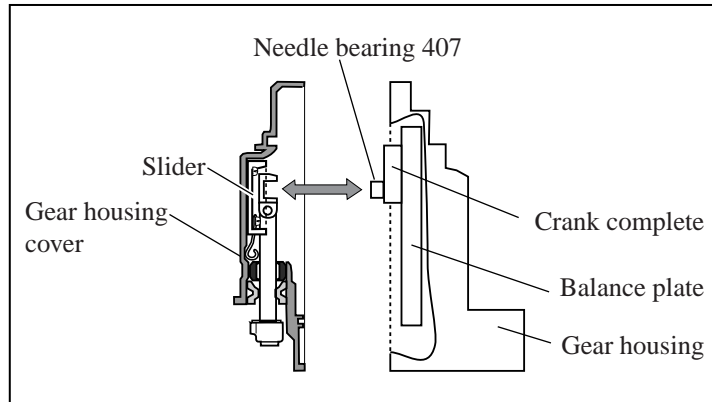
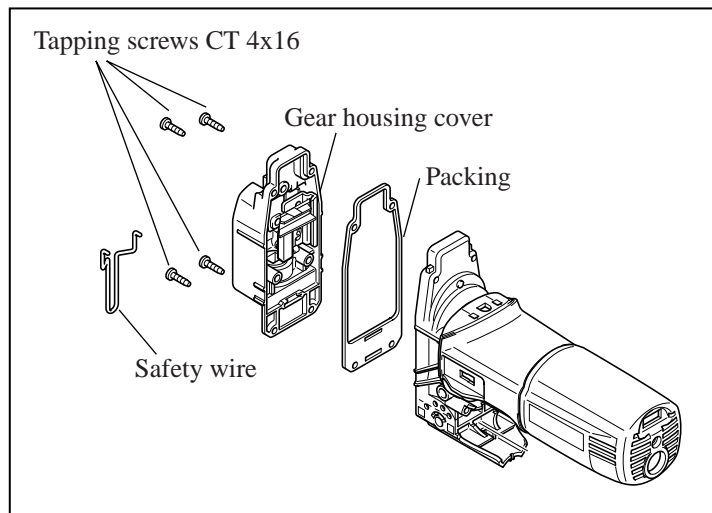

Fig. 17



▶ Repair

[7] Disassembling blade holder

1. Disassemble Rod with referring to [5] Disassembling Gear housing cover section in page 4.
2. Disassemble Dust cover, and then disassemble Retaining ring R-18 as illustrated in **Fig. 18**.
Blade holder and Torsion spring 15 are separated from Rod as illustrated in **Fig. 19**.

Fig. 18

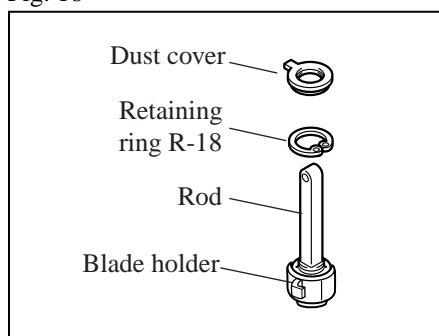
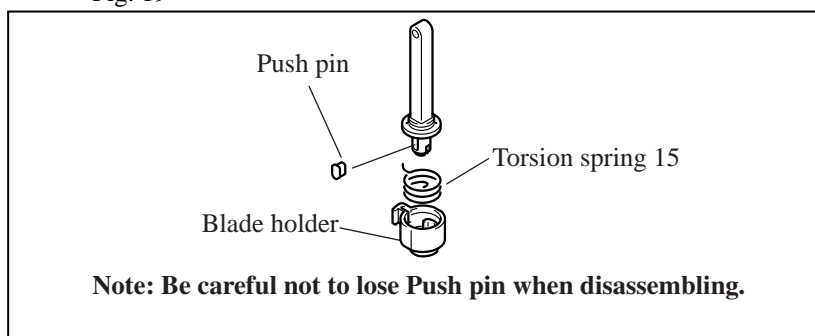

Fig. 19



[8] Assembling blade holder

1. Apply Makita grease FA No.2 to Push pin.
Insert Push pin to Rod.
Insert the short hook end of Torsion spring 15 to Rod. (**Fig. 20**)
2. Align the mark of Blade holder and the long hook end of Push pin, and then cover Blade holder on Rod with Torsion spring 15. (**Fig. 21**)
3. Bring the long hook end to the space A of Blade holder by turning clockwise. (**Fig. 22**)

Fig. 20

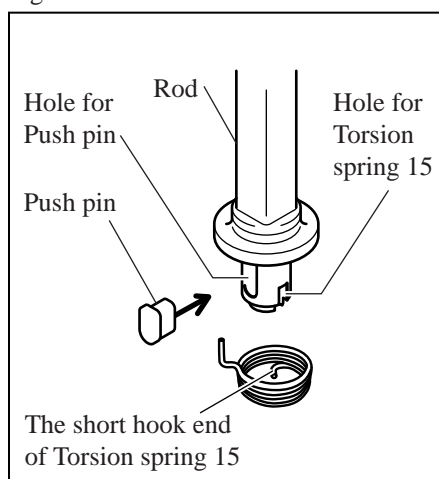

Fig. 21

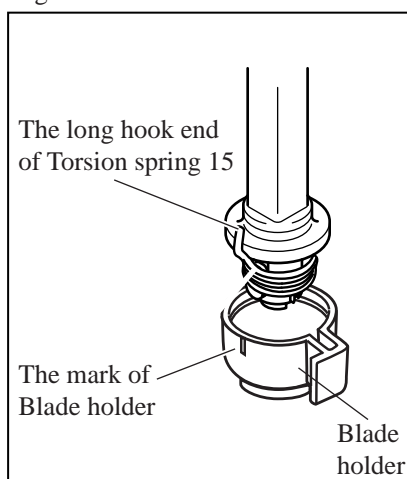
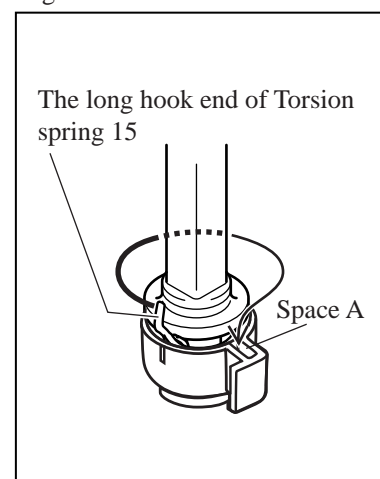

Fig. 22



4. Push Rod into Blade holder, and then assemble Retaining ring R-18 to the groove in Blade holder. (**Fig. 23**)
5. Install Dust cover as illustrated in **Fig.24**.

Fig. 23

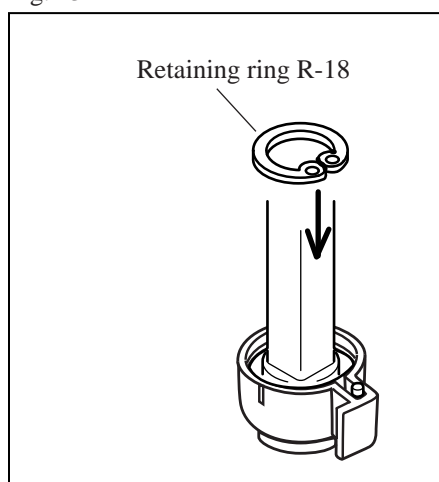
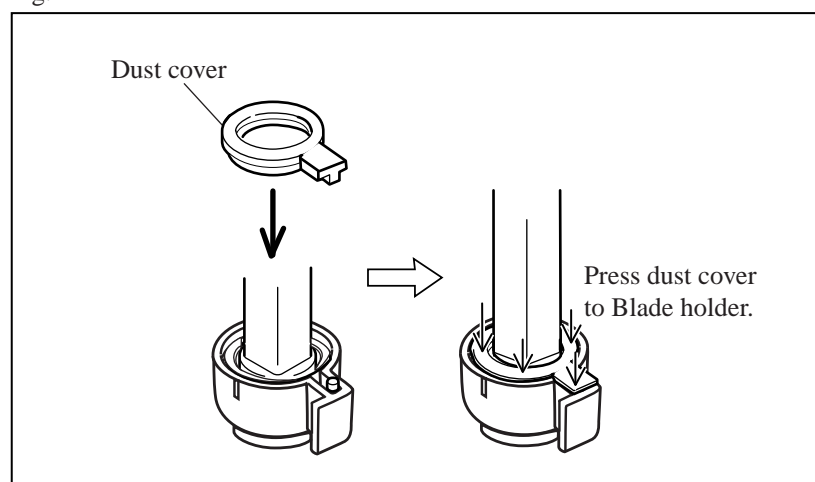

Fig. 24



► Repair

[9] Disassembling parts in Gear housing

1. After separating Safety wire from Gear housing cover, remove four 4x16 Tapping screws CT . Gear housing cover is separated from Gear housing as illustrated in **Fig. 25**.

Fig. 25

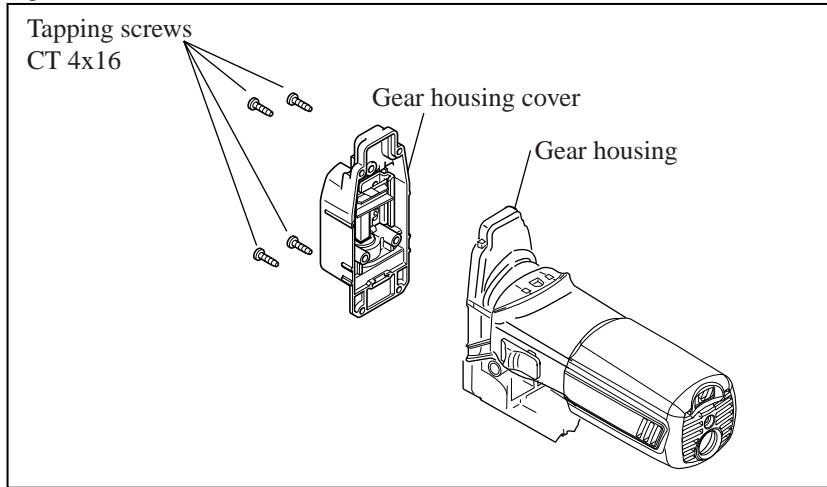

2. While Locking Crank complete with 1R235, remove two M4x12 Hex socket head bolts. (**Fig. 26**)

Fig. 26

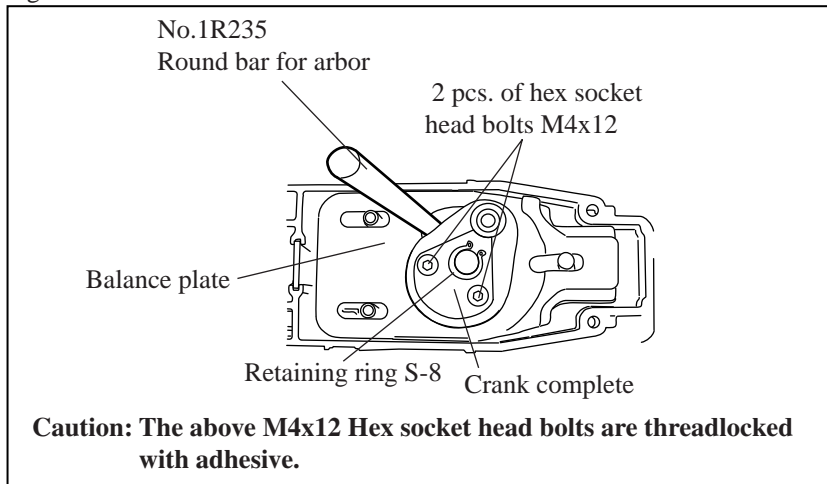

3. Disassemble Retaining S-8. Then, the inner parts are disassembled from Gear housing as illustrated in **Fig.27**.

Fig. 27

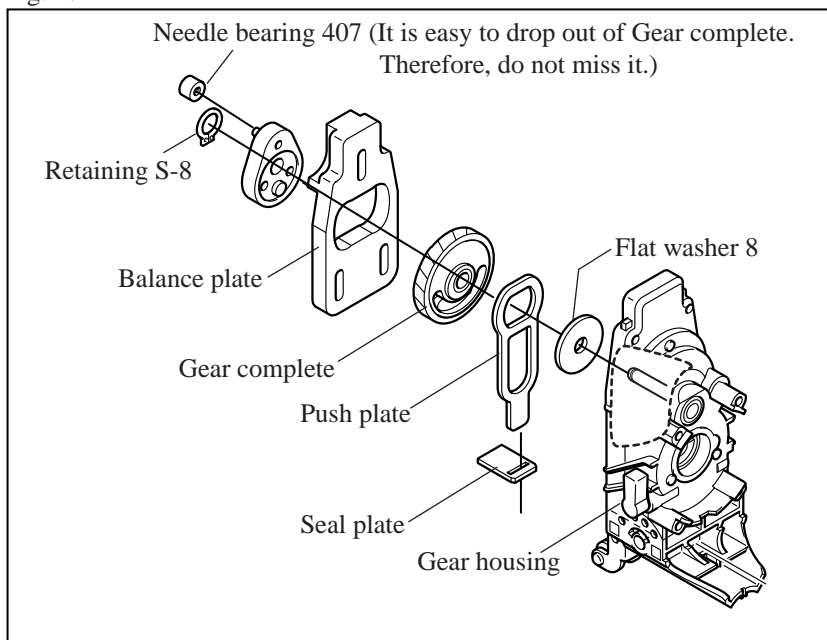

► Repair

[10] Assembling parts in Gear housing

1. Pass the shaft of Gear housing through Flat washer 8. **(Fig. 28)**
2. After assembling Seal plate to Push plate, pass the shaft of Gear housing through Push plate with Seal plate. **(Fig. 29)**
3. Lubricate the parts with referring to [1] Lubrication in page 2.
4. Pass the shaft of Gear housing through Gear complete and Balance plate. **(Fig. 30)**
5. Assemble Crank complete to Gear housing. Push down Crank complete while turning it until the groove on shaft of Gear housing can be seen. **(Fig. 31)**
6. While locking crank complete with 1R235, fasten Crank complete with two M4x12 Hex socket head bolts with adhesive. **(Fig. 32)**

Note: Do not fasten with the used M4x12 Hex socket head bolts. The fresh M4x12 Hex socket head bolts with adhesive have to be used. The fastening torque of these bolts has to be 2.4 - 3.5 N.m.

7. Install Retaining ring S-8 to the groove on the shaft of Gear housing to secure the components. **(Fig. 33)**

Fig. 28

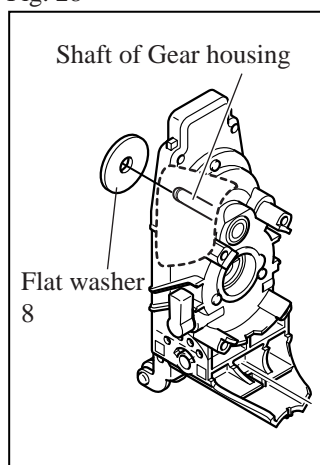

Fig. 29

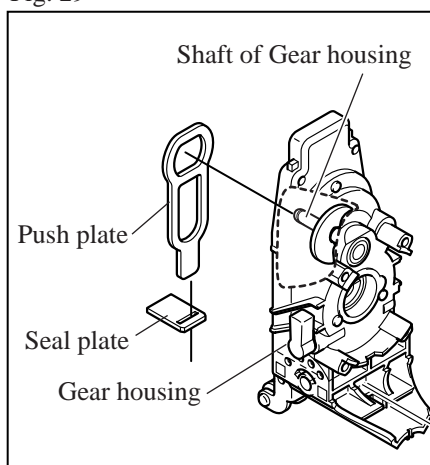

Fig. 30

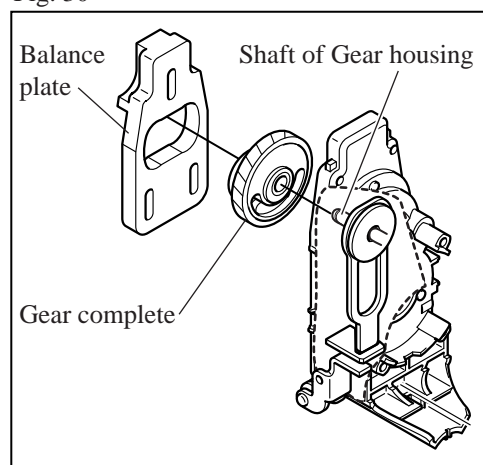

Fig. 31

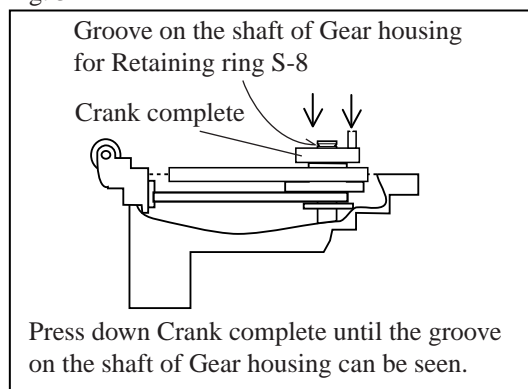

Fig. 32

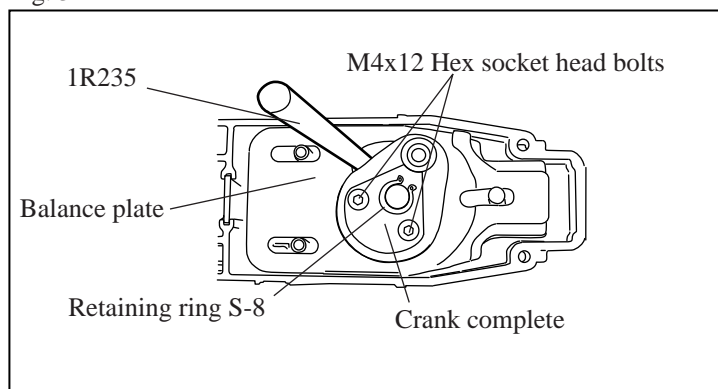
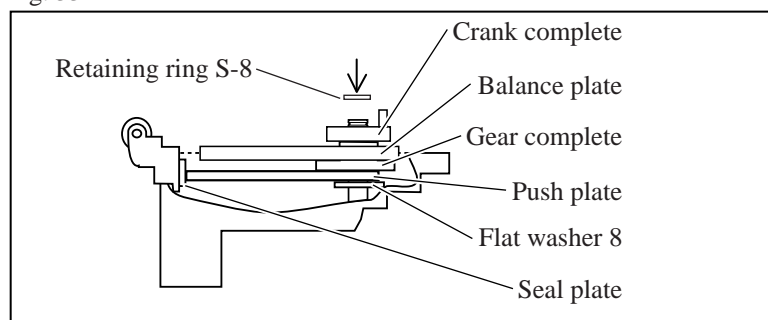

Fig. 33



Repair

[11] Disassembling armature

1. With referring to the following section, disassemble Head covers L and R, and gear housing cover.

[4] Disassembling Head cover section in page 3

[5] Disassembling Gear housing cover section" at page 4

2. Remove Rear cover by unscrewing 4 x 18 Tapping screw. And then, remove Carbon brushes. (**Fig. 34**)

Fig. 34

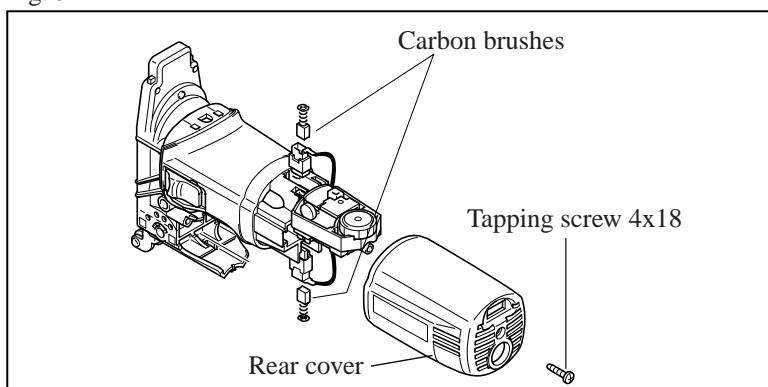

3. Remove Retaining ring S-8, and separate Crank complete, Balance plate and Gear complete from the shaft of Gear housing as illustrated in **Fig. 35**.

Note: It is not necessary to remove M4x12 Hex socket head bolt, Crank complete and Gear complete from Balance plate.

Be careful not to lose Needle bearing 407.

Fig. 35

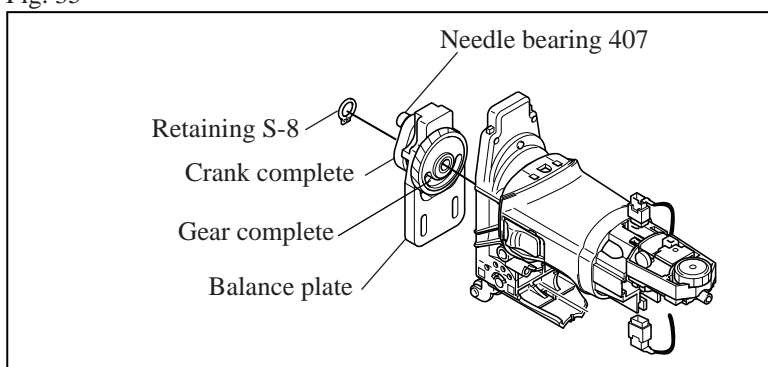

4. Remove four 4x30 Tapping screws, and then separate Gear housing from Motor housing.

Separate Armature from Gear housing by striking Gear housing with plastic hammer. (**Fig. 36**)

Fig. 36

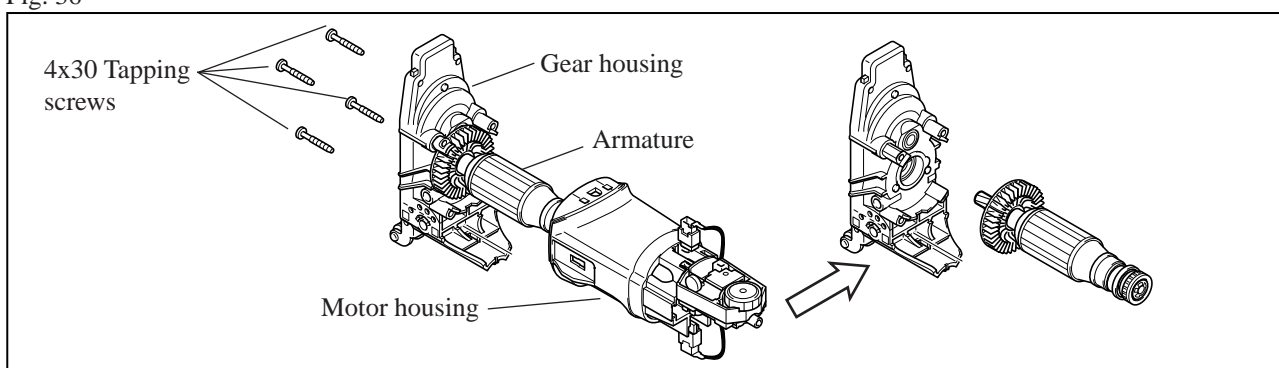

5. Remove Self lock with slotted screwdriver. Magnet sleeve, Wave washer 6 and Rubber ring 19 are removed from Armature shaft. **Fig. 37**.

Fig. 37

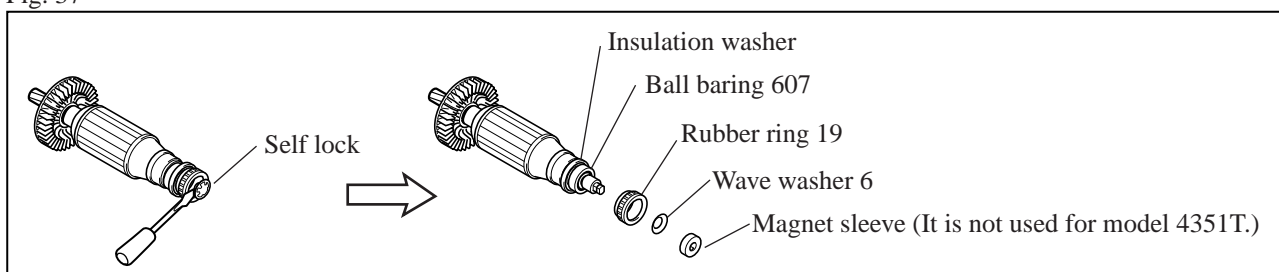

► **Repair**

6. Remove Ball bearing 607 LLB from Armature shaft as illustrated in **Fig. 38**.

Fig. 38

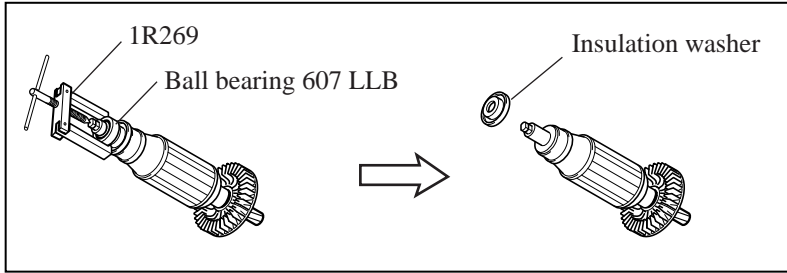

[12] Assembling armature

Note: • Do not assemble the used self lock. The self lock has to be always replaced with the fresh one.

- Pay attention to the assembling direction of Self lock and Wave washer 6. (Fig. 39)
- Magnet sleeve is installed to the armature shaft on commutator side for sensing the variation of rotating speed. If it would be damaged, the electronic speed control does not work any more. Therefore, press Magnet sleeve by hand carefully instead of arbor press while applying 1R026 to self lock.

Fig. 39

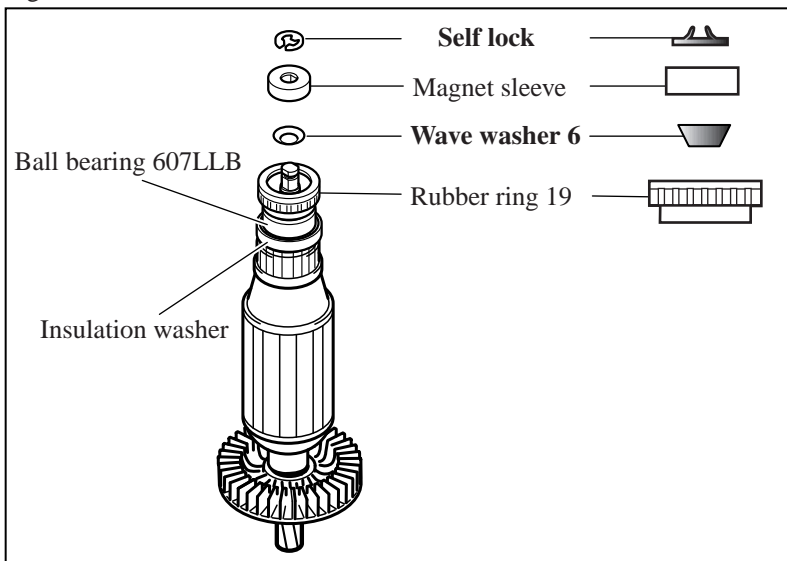

[13] Disassembling Lever 17 (for orbital action mode change)

1. With referring to the following section, Head covers L and R, and Gear housing cover.

[4] Disassembling Head cover section section in page 3

[5] Disassembling Gear housing cover section in page 4

2. Remove Stop ring E-5 from the shaft of Lever 17 with slotted screwdriver. (**Fig. 40**)

3. While aligning Lever 17 with indication III, pull it out from Gear housing. (**Fig. 41**)

Then, Cap 5 and Compression spring 3 are removed. (**Fig. 42**)

Fig. 40

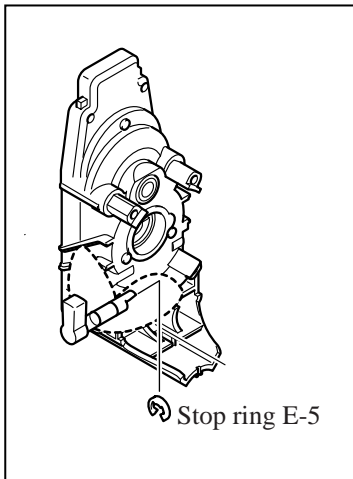

Fig. 41

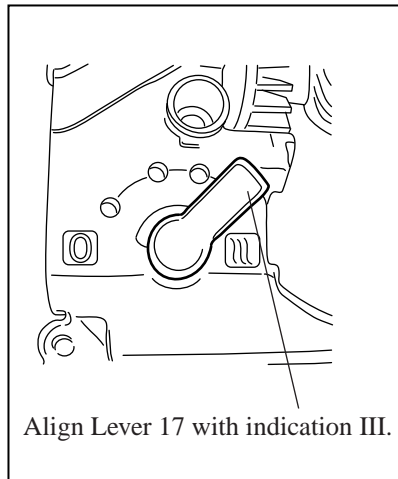
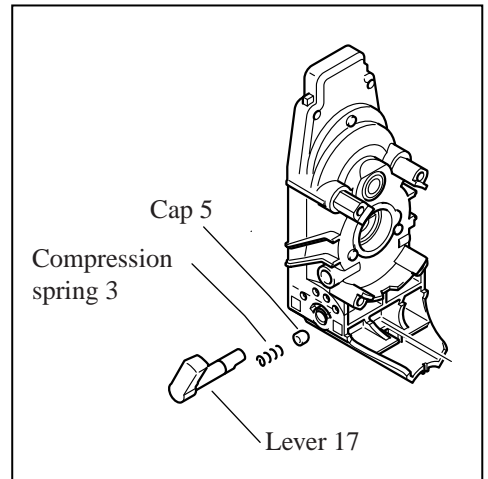

Fig. 42



► Repair

[14] Disassembling Motor section

1. Remove Rear cover from Motor housing by unscrewing 4x18 Tapping screw.
2. Disconnect the connector of LED circuit. the electric parts module can be pulled out from Motor housing. **(Fig. 43)**

Fig. 43

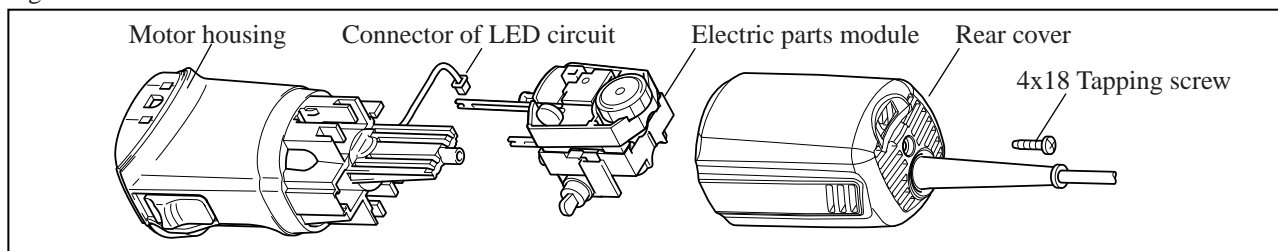

3. With referring to [4] **Removing Head cover** in pages 3 and 4, remove Head covers and Gear housing cover.
4. Remove carbon brushes.
5. After removing Retaining ring S-8 from the shaft of Gear housing, separate the Crank section from Gear housing by striking Gear housing. Disassembling the Crank section is not required for removal of Motor section. **(Fig. 44)**
6. After removing 4x30 Tapping screws, remove Gear housing from Motor housing by striking Gear housing. Armature can be removed together with Gear housing as illustrated in **Fig. 45**.
7. Move Switch rod with 1R291 in the direction illustrated by arrow and remove Switch lever from Motor housing. **(Fig. 46)**

Fig. 44

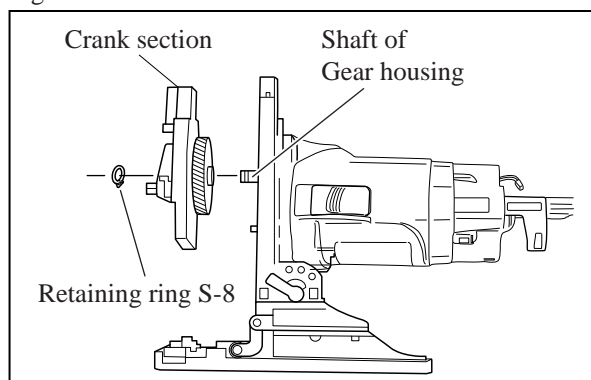

Fig. 45

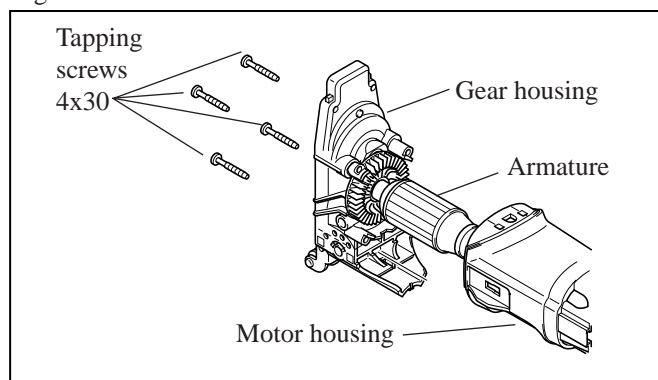
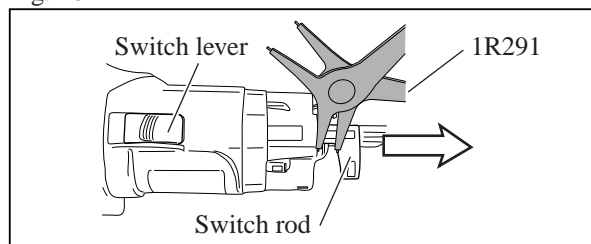

Fig. 46



[15] Assembling Motor section

1. Insert Switch rod into Motor housing to align their wide square holes. Figs. 47 and 47A.
2. While pressing Switch rod to the wall of Motor housing, insert Switch lever into the aligned wide square holes.
3. Push Switch rod in direction to Gear housing side on condition that Switch lever is in OFF position. Switch lever and Switch rod can be interlocked.
4. Connect the connector of LED circuit.

Fig. 47

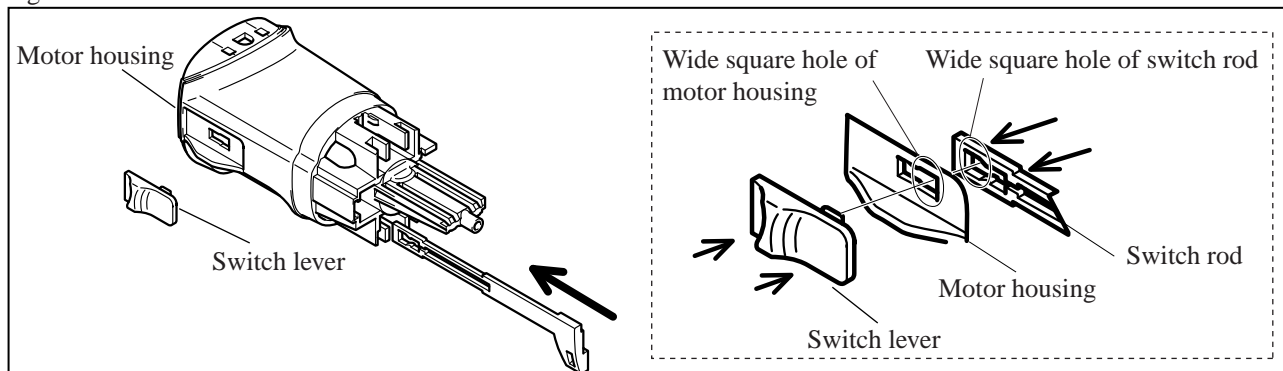

► **Circuit diagram in the rear of motor housing**

4351CT (with controller, without LED job light)

4351FCT (with controller and LED job light)

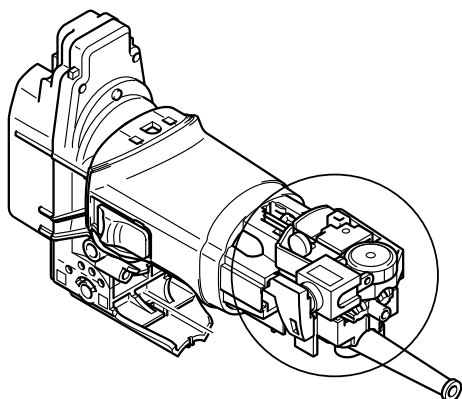

 : Connecting with terminal

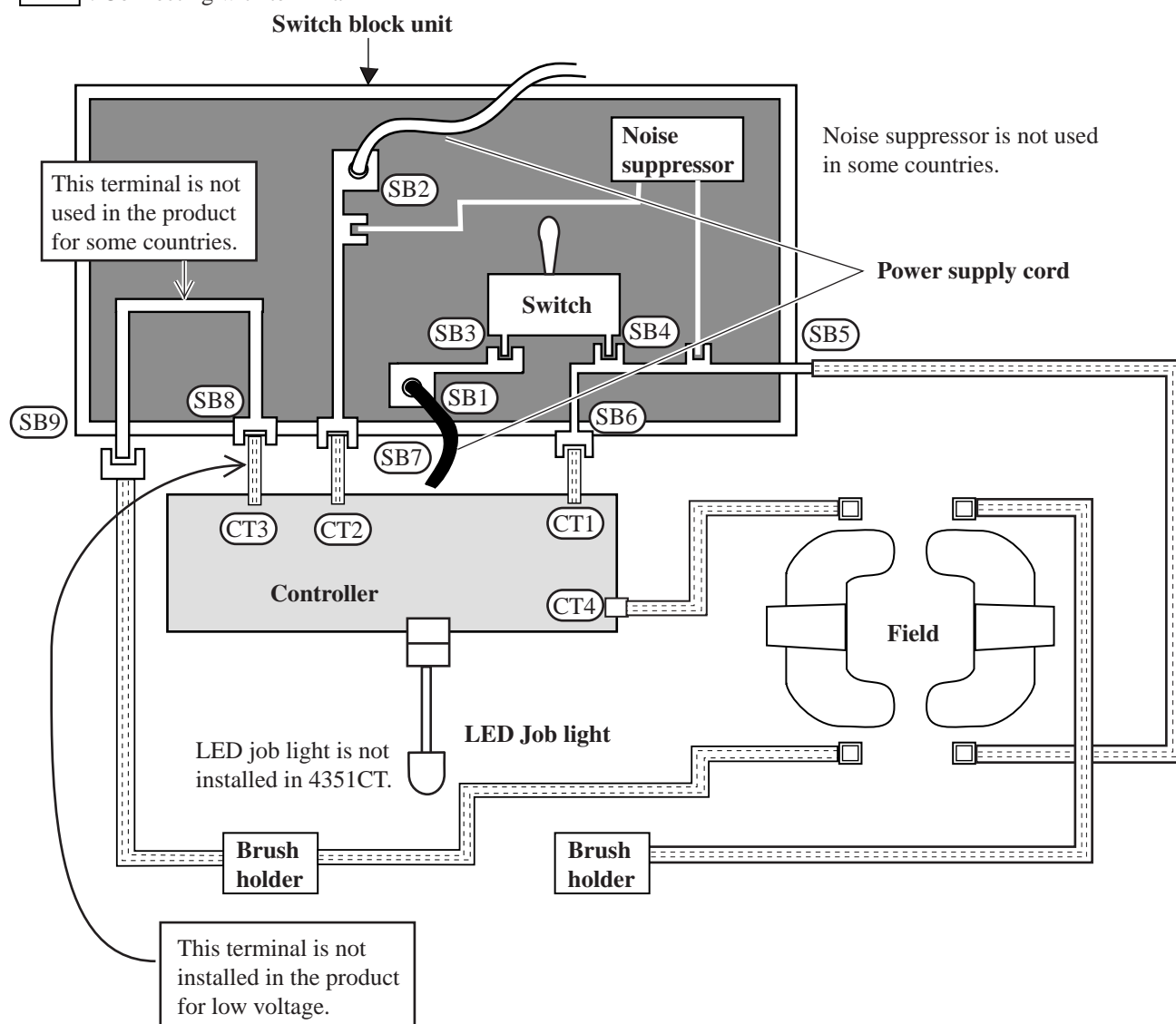

► **Circuit diagram in the rear of motor housing**

4351T (without controller and LED jog light)

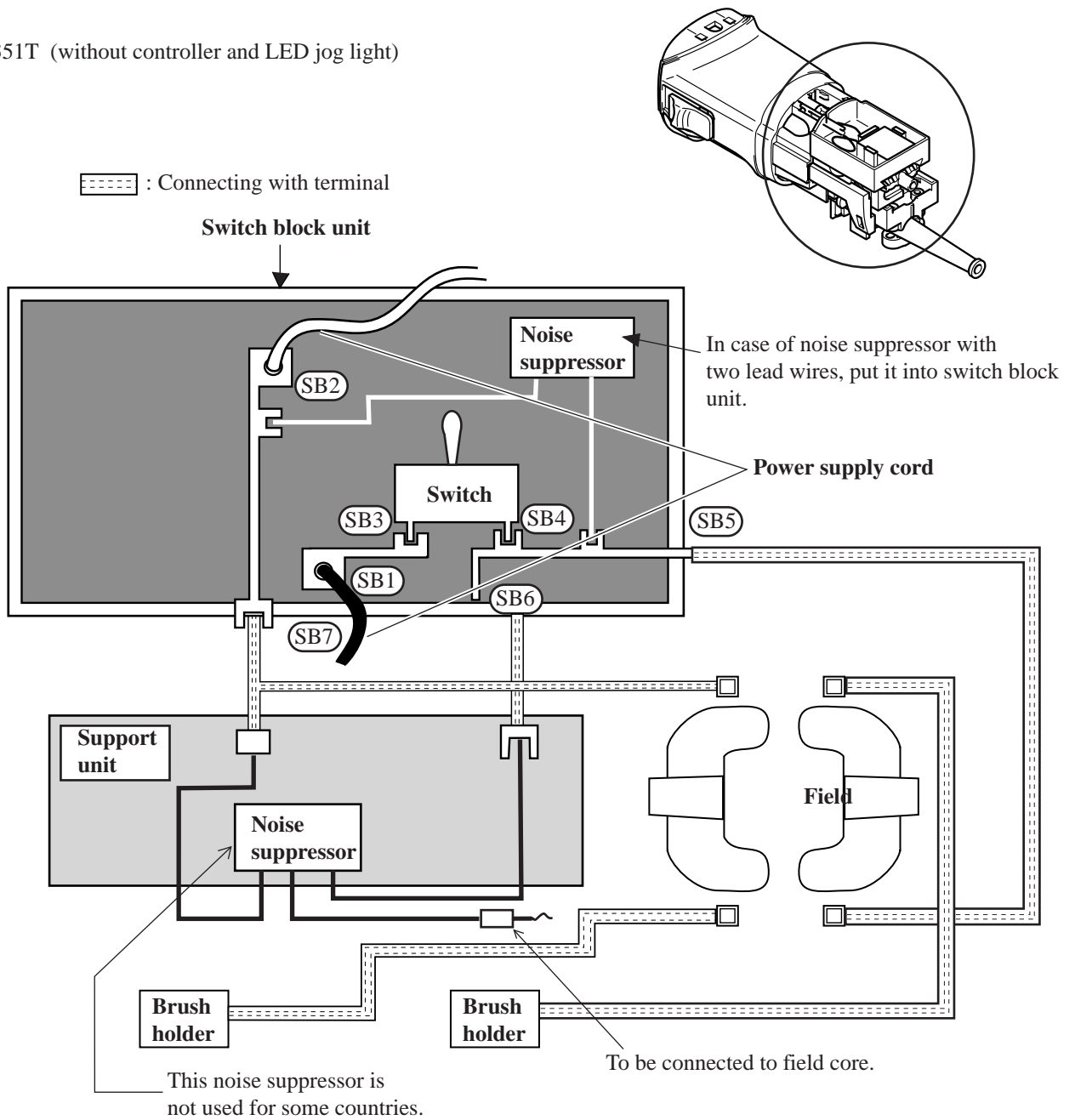

► **Wiring diagram**

4351T (without controller and LED jog light)

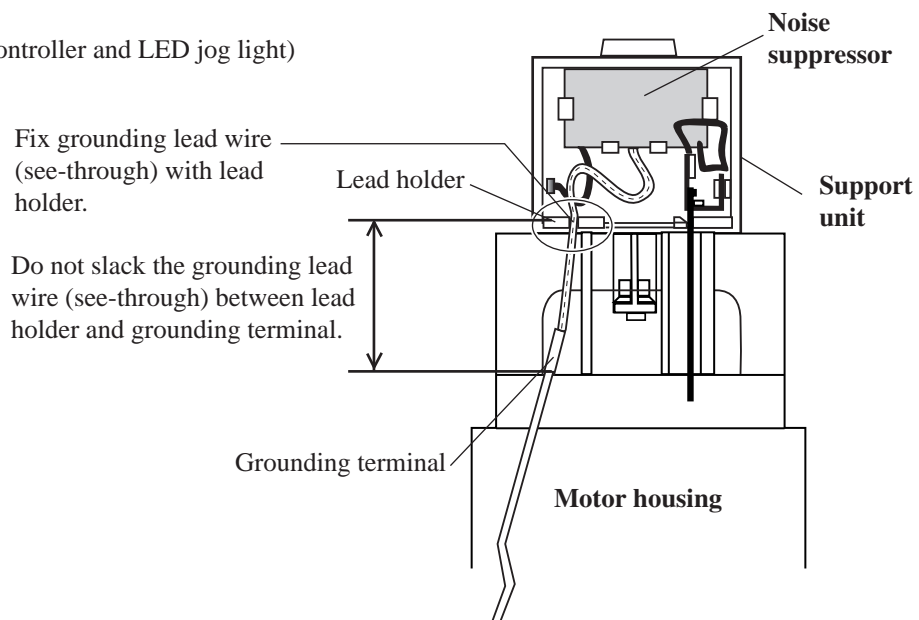

► **Wiring diagram**

4351FCT

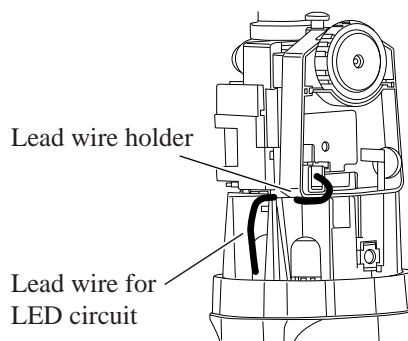
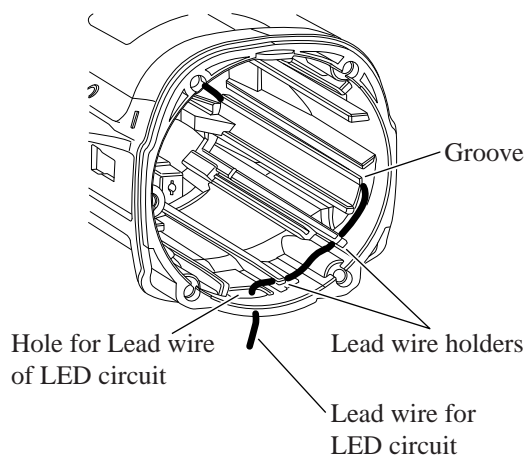

Route Lead wire for LED circuit as follows:

- 1) through the hole of Motor housing
- 2) in Lead wire holders
- 3) in groove

Put Lead wire for LED circuit into Lead wire holder.

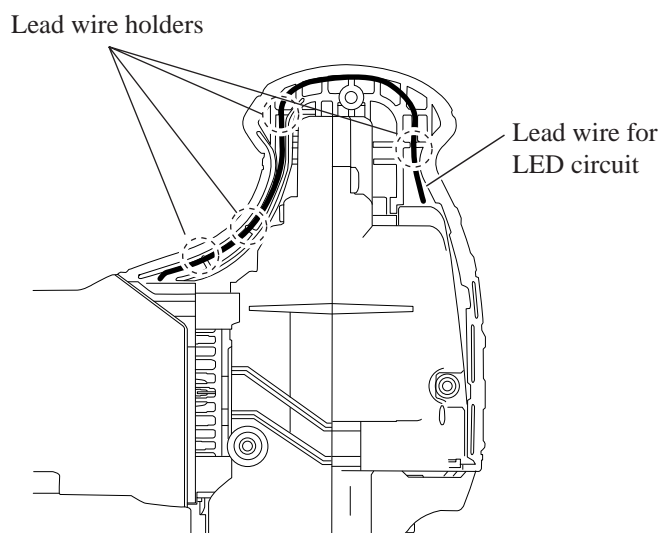

Put Lead wire for LED circuit into Lead wire holders in Head cover L.