

TECHNICAL INFORMATION

Makita

New Tool

Models No. ▶ 500

Description ▶ MAKITA 140mm Circular saw

CONCEPTION AND MAIN APPLICATIONS

This machine is the small type circular saw or the reformed version of the 5000SB and 5000SBR, developed according to the design of Giujiaro while focusing on the design. Compared with the conventional model, it has been developed while attention is paid in more beautiful appearance and well functionality.

Note that the M500 is for exclusive in export.

The difference between 500 and M500 is just the housing color.

500---green (standard), M500---red

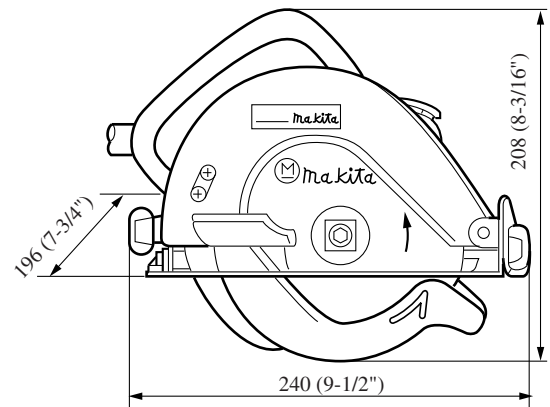

▶ Specifications

Voltage(V)	Current(A)	Frequency (Hz)	Consumed power(W)	Rated output(W)	Max. output(W)
100	5.8	50-60	550	260	440
115	5.0	50-60	550	260	440
200	2.9	50-60	550	260	440
220	2.6	50-60	550	260	440
230	2.5	50-60	550	260	440
240	2.4	50-60	550	260	440

No load speed (/min.)	4000	
Saw blade(mm)	Inner dia.	16
	Outer dia.	130-140
Cutting capacity (When the saw with dia. 140 mm is used)	0-45mm(90) 0-29mm(45)	
Weight(kg)	2.5	
Cord length(m)	2	

▶ Standard equipment

Parallel ruler
Box wrench 9(for loading/unloading the saw blade)
+ Screw driver (for adjusting the living knife)

▶ Optional accessories

Saw blade 140 for both vertical/horizontal purposes
Saw blade 140 for horizontal sawing

The standard equipment for the tools shown may differ from country to country.

► Repair

Assembling of the switch etc.

Set the switch, the lever, and the compression spring 4 at the positions on the motor housing as shown on the below figure in a way that they may not float. Also when setting the handle cover to the motor housing, use care that the parts shown above and the lead wire are not caught in each other.

