

# T

## TECHNICAL INFORMATION



Product

**Models No.** ▶ 5604R

**Description** ▶ 165 mm (6-1/2") Circular Saw

### CONCEPTION AND MAIN APPLICATIONS

Model 5604R is developed for getting European market with the marketable price.

The brief benefits are low noise, with shaft lock, and more handy than competitors.

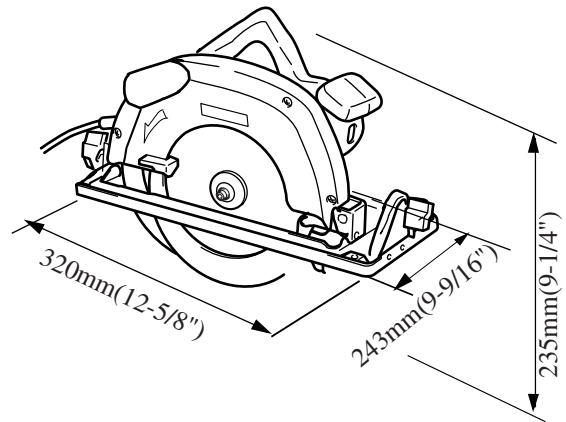

### ▶ Specifications

Voltage (V)	Current (A)	Cycle (Hz)	Continuous Rating (W)		Max. Output(W)
			Input	Output	
230	4.3	50/60	950	550	1,100
240	4.2	50/60	950	550	1,100
110	8.7	50/60	950	550	1,100

Blade Diameter	165 mm (6-1/2")	
Arbor diameter	20 mm (13/16")	
Max. cutting capacities	At 90°	54 mm (2-1/8")
	At 45°	35 mm (1-3/8")
No load speed	5,000 R/min.	
Net weight	3.6 kg (7.9 lbs)	

### ▶ Standard equipment

Rip fence (Guide rule), Hex wrench 5, Carbide-tipped saw blade 165-10

The standard equipment for the tools shown may differ form country to country

### ▶ Optional accessories

Various 165mm Saw Blades (Thickness of Tip : 2mm)

## ► Repair

The spare parts to be installed on the commutator side of armature have to be mounted as follows.

1. Mount the Insulation Washer on the armature shaft.
2. Install Rubber Ring 22 on Ball Bearing 608LB in advance.
3. Mount the above Ball Bearing 608LB.
4. Mount the Rubber Washer 13.

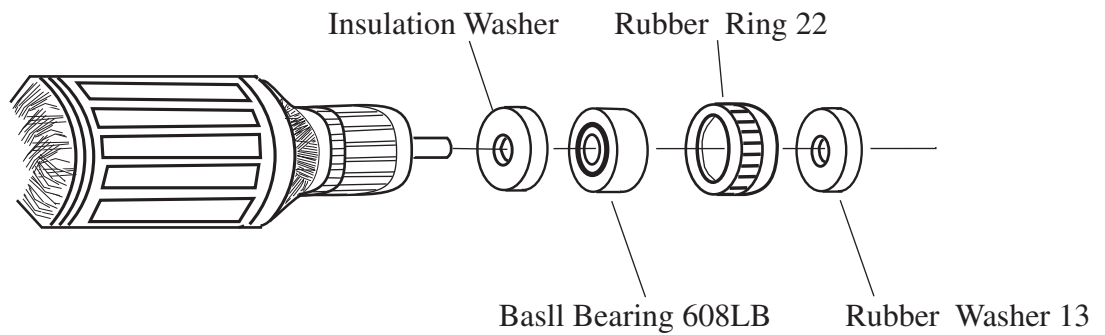

## ► Diagram

