

# T ECHNICAL INFORMATION

**Makita**

New Tool

**Models No.** ▶ 5703R

**Description** ▶ 190 mm(7-1/2") Circular Saw

## CONCEPTION AND MAIN APPLICATIONS

Model 5703R is a redesigned version of the existing Models 5800BR and SR1800. It is equipped with a riving knife, larger base, more efficient chip/sawdust ejection port, etc. It complies with CENELEC Standard.

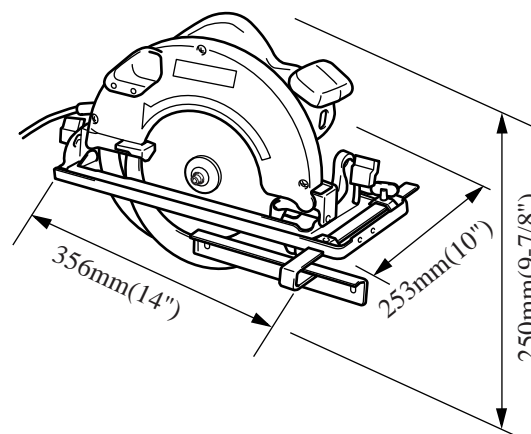

### ► Specifications

Voltage (V)	Current (A)	Cycle (Hz)	Continuous Rating (W)		Max. Output(W)
			Input	Output	
100	13.5	50/60	1,300	540	1,750
115	12.0	50/60	1,300	540	1,750
220	6.2	50/60	1,300	540	1,750
230	6.0	50/60	1,300	540	1,750
240	5.7	50/60	1,300	540	1,750

<b>Blade diameter</b>	190 mm (7-1/2")	
<b>Arbor diameter</b>	30 mm (1-3/16")	
<b>Max. cutting capacities</b>	At 90°	66 mm (2-5/8")
	At 45°	46 mm (1-13/16")
<b>No load speed</b>	4,800 R/min.	
<b>Net weight</b>	5.2 kg (11.5 lbs)	

### ► Standard equipment

Rip fence (Guide rule), Hex wrench 5, Carbide-tipped saw blade 190-12

### ► Optional accessories

Carbide-tipped saw blade 190-12, Joint (for connecting to vacuum cleaner), Inner flange 40 (for saw blade with arbor 20 mm; 3/4" in diameter)

The standard equipment for the tools shown may differ from country to country