

TECHNICAL INFORMATION



PRODUCT

P 1 / 5

Models No. ▶ 5704R, 5704RK

Description ▶ Circular Saw 190mm

CONCEPTION AND MAIN APPLICATIONS

Model 5704R has been developed as the 190mm Circular Saw with riving knife.

This easy-to-control Circular Saw also features its superiority to competitors in Low noise, Low vibration and Cutting speed. Save more money, and get higher performance.

Model 5704RK comes with plastic carrying case.

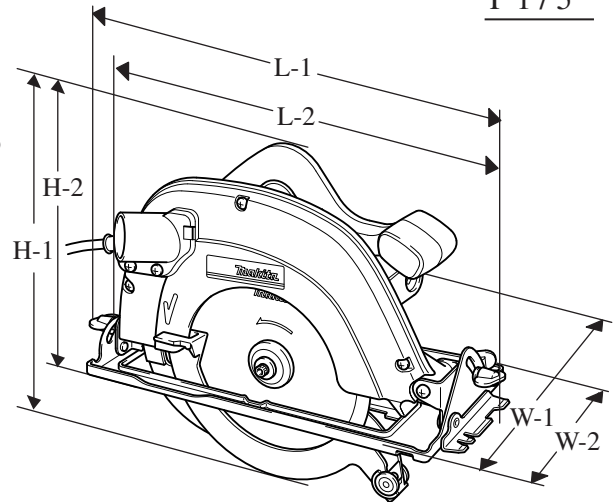

Dimensions : mm (")	
Length (L-1)	345 (13-5/8)
Length (L-2)	328 (12-7/8)
Height (H-1)	253 (10)
Height (H-2)	181 (7-1/8)
Width (W-1)	238 (9-3/8)
Width (W-2)	150 (5-7/8)

► Specification

Voltage (V)	Current (A)	Cycle (Hz)	Continuous Rating (W)		Max. Output(W)
			Input	Output	
110	12	50 / 60	1,200	740	1,400
220	5.3	50 / 60	1,100	610	1,100
230	5.5	50 / 60	1,200	740	1,400
240	5.3	50 / 60	1,200	740	1,400

No load speed : rpm.= min.-1	4,900	
Size of blade	Diameter : mm (")	190 (7-1/2)
	Arbor : mm (")	30 (1-3/16) * 20 (13/16) for China
Max. cutting capacities : mm (")	at 90°	66 (2-5/8)
	at 45°	46 (1-13/16)
	at 50°	
Electric brake	No	
Protection from electric shock	by double insulation	
Net weight : Kg (lbs.)	4.6 (10.1)	
Cord length : m (ft)	2.5 (8.2)	

► Standard equipment

- * Carbide tipped saw blade 190mm (7-1/2) 1 pc. (for China : 24T for Europe : 12T)
- * Rip fence 1 pc.
- * Hex wrench 1 pc.
- * Joint assembly (for connecting vacuum cleaner)..... 1 pc.
- * Plastic carrying case 1 pc. (only for Model 5704RK)

< Note > The standard equipment for the tool shown may differ from country to country.

► Optional accessories

- * Various saw blades

<Note> First of all, detach the saw blade for safety repair.

< 1 > Replacing motor housing, base, and blade case

(1) Motor housing

Take off carbon brush. and then, unscrew 3 pcs. of pan head screws M5 x 45. So, motor housing (including armature, field etc.) can be separated from blade case. See Fig. 1.

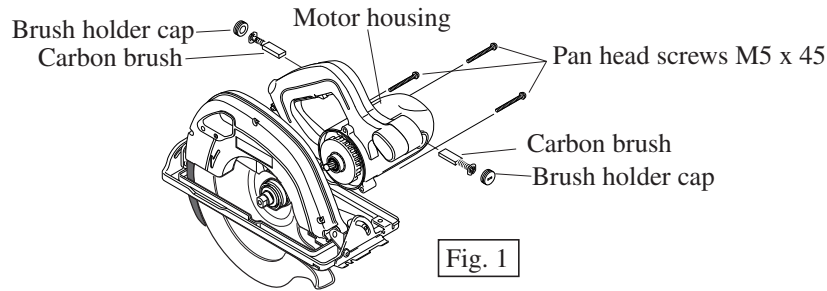

Fig. 1

(2) Base

Disassemble safety cover and riving knife holder from the motor section by removing retaining ring S-40 as illustrated in Fig. 2.

And then, disassemble the following parts which are fastening the motor section on base. See Fig. 2A. So, base can be separated from motor section.

- (53) Hex lock nut M5 x 8 (54) Pan head screw M5 (55) Cap square neck bolt M8x24
- (70) Hex nut M8 (64) Flat washer 8 (65) Flat washer 8
- (67) Lever plate including (66) Rubber cap, (68) Lock plate and (69) Pan head screw M4x8

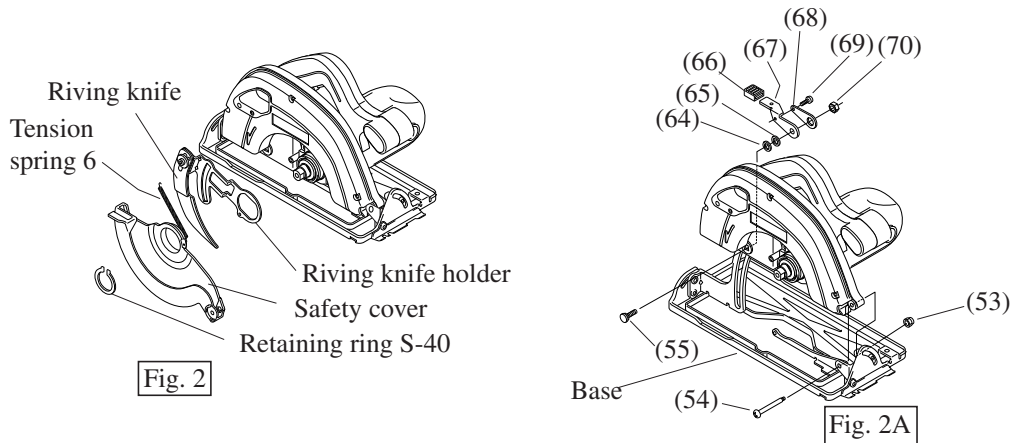

Fig. 2

Fig. 2A

(3) Blade case

After separating base from motor section, disassemble bearing box (including spindle, helical gear 49, ball bearing 608ZZ etc.) by unscrewing 4 pcs. of pan head screws M4x16 as illustrated in Fig. 3.

And then, separate blade case from motor housing by unscrewing 3 pcs. of pan head screws M4x45 as illustrated in Fig. 3A.

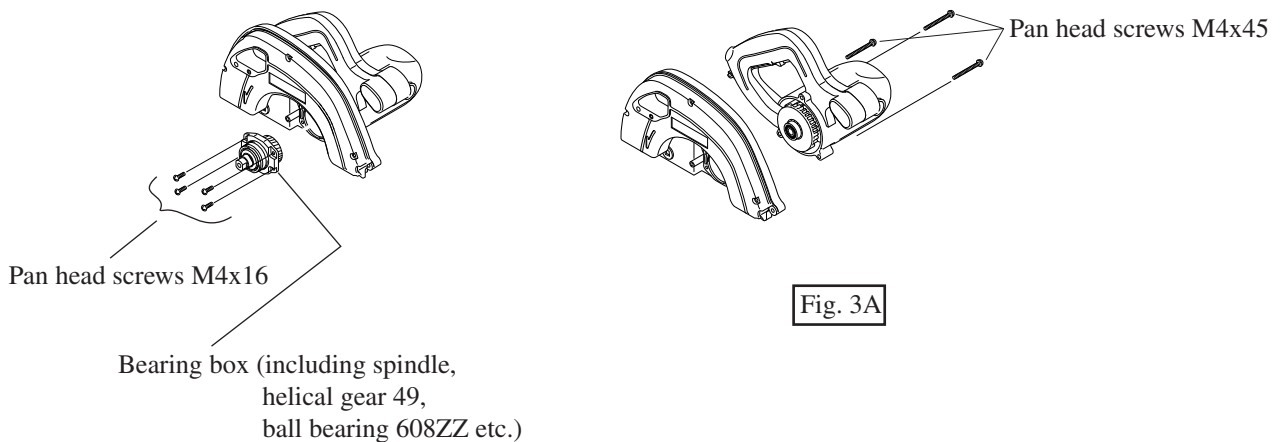

Fig. 3

Fig. 3A

(4) Assembling lever plate

Lever plate's angle against base has to be as illustrated in Fig.4, when the machine is adjusted to max. cutting depth.

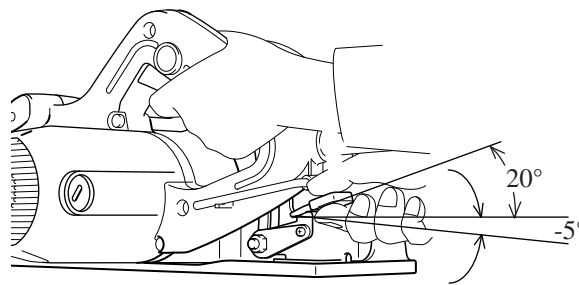

Fig. 4

Do not forget to assemble 2 pcs. of flat washers 8 between blade case and depth guide, when assembling lever plate. See Fig. 4A.

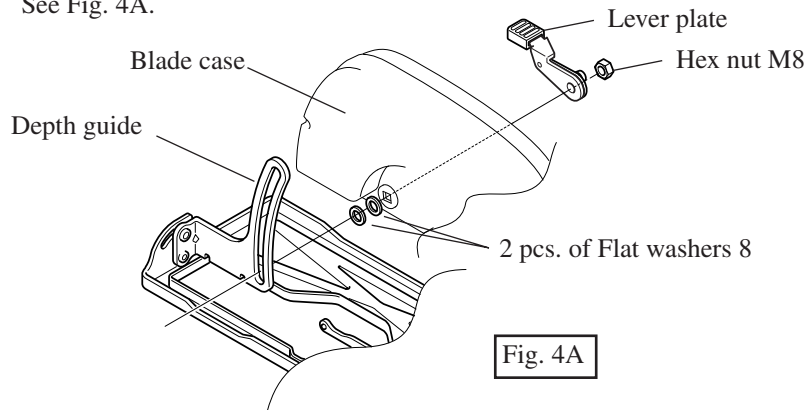

Fig. 4A

< 2 > Replacing gear section

(1) Disassembling gear section

After removing ball bearing 608ZZ, hold ring 12 installed to bearing box, with 1R031 "bearing setting pipe". And disassemble spindle by pressing it down with arbor press as illustrated in Fig. 5. So, the gear section can be disassembled as illustrated in Fig. 5A.

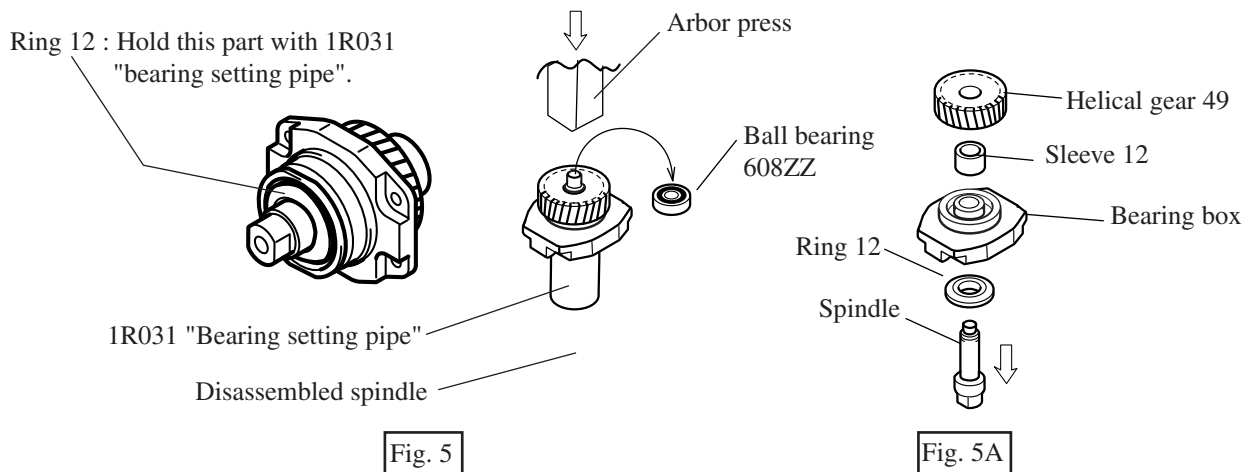
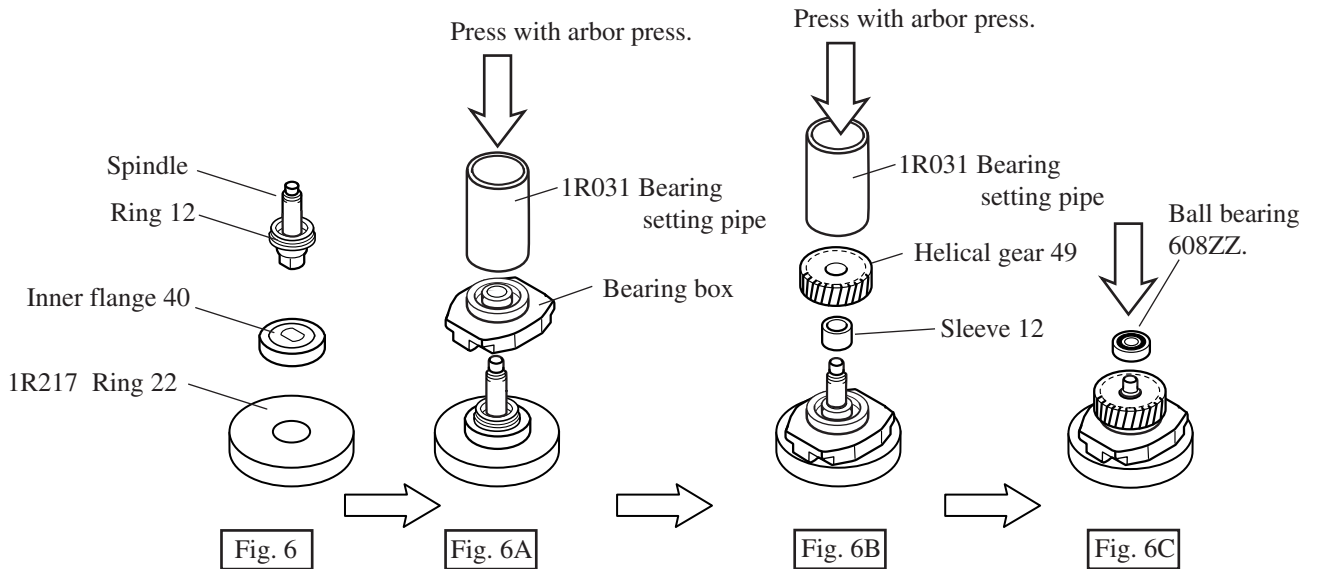

Fig. 5

Fig. 5A

(2) Assembling gear section

1. Assemble ring 12 to spindle.
Accept the brim portion of the spindle with inner flange 40, and put the spindle and inner flange 40 on 1R217 "ring 22". See Fig. 6.
2. Assemble bearing box in which ball bearing 6201-NLR has been assembled in factory as its integral part, by pressing with arbor press. See Fig. 6A.
3. After attaching sleeve 12, assemble helical gear 49 by pressing with arbor press. See Fig. 6B.
4. Assemble ball bearing 608ZZ.



< Note 1 > Before assembling, make sure that O ring 46 has been installed to the bearing box in the process shown in Fig. 6A.

< Note 2 > Before mounting the bearing box shown in Fig.6C to blade case, apply 10 g MAKITA grease N No.1 into the gear room of the blade case.

< 3 >Assembling riving knife holder, and the adjustment of riving knife holder

1. Assemble riving knife holder to bearing box with meeting the hole of riving knife holder with the boss of link as illustrated in Fig. 7.
2. When the machine is adjusted to max. cutting depth, the riving knife has to be so adjusted, that the distance between the riving knife and the toothed rim of the saw blade comes to 1 - 5mm, as illustrated in Fig. 7A.

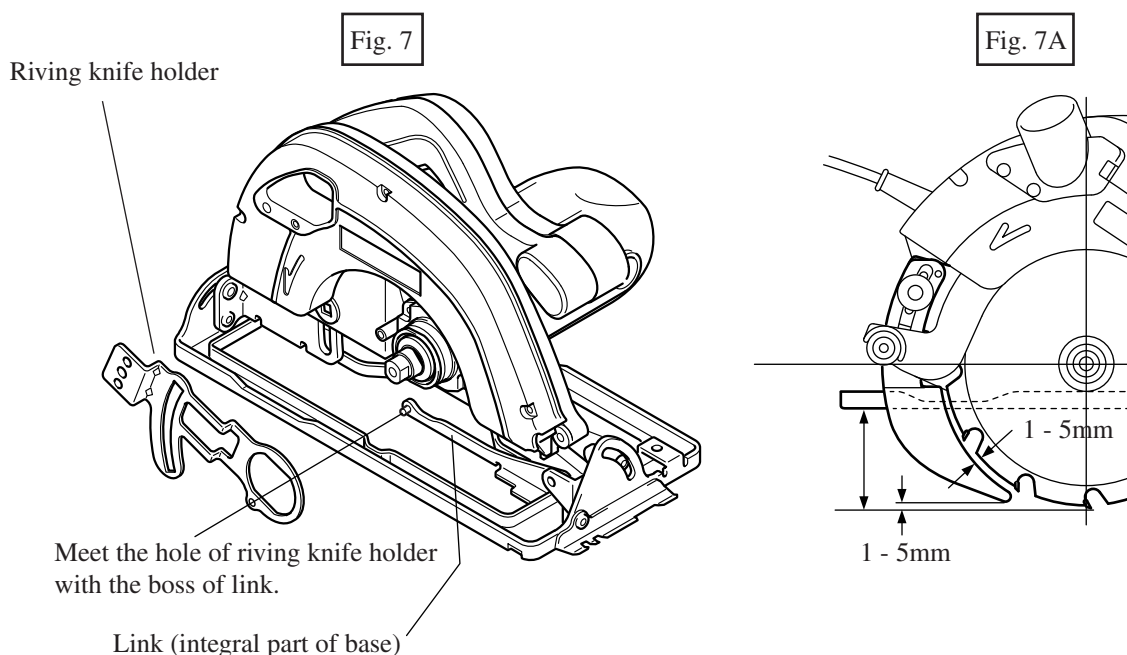

► **Repair**

< 4 > Assembling tension spring 4

Tension spring 4 has to be hooked on the safety cover as illustrated in Fig. 8.

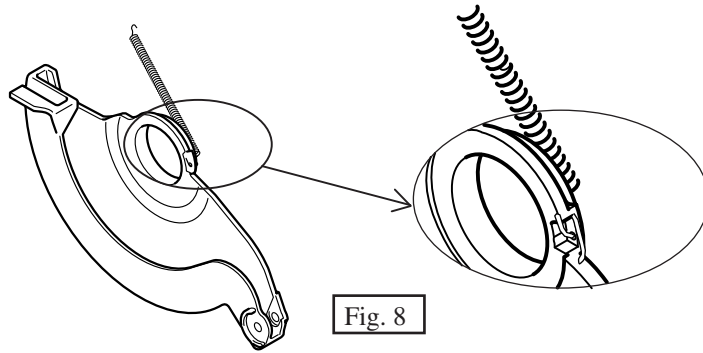
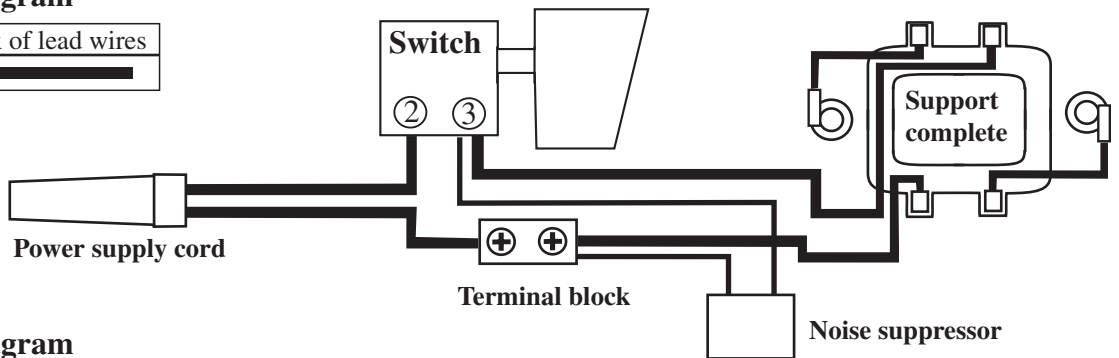

Fig. 8

► **Circuit diagram**

Color index of lead wires	
Black	



► **Wiring diagram**

