

For Models ▶ 5903R

Description ▶ 235 mm (9-1/4") Circular Saw

CONCEPTION AND MAIN APPLICATIONS

Model 5903R is a redesigned version of the existing Model 5900BR. Model 5903R is equipped with rivingknife, electric brake, more powerful Makita motor, more efficient chip/sawdust ejection port, extremely durable aluminum base, Standard. etc. It complies with CENELEC

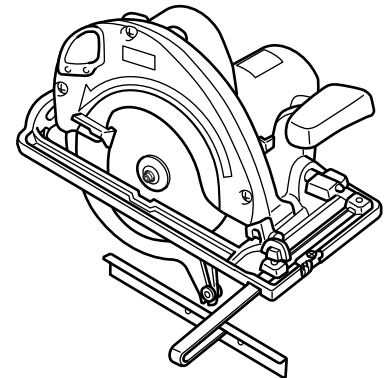

▶ Specifications

| Voltage (V) | Current (A) | Cycle (Hz) | Continuous Rating (W) | | Max. Output(W) |
|-------------|-------------|------------|-----------------------|--------|----------------|
| | | | Input | Output | |
| 100 | 15.0 | 50/60 | 1,430 | 650 | 2,300 |
| 115 | 15.0 | 50/60 | 1,550 | 700 | 2,300 |
| 200 | 10.5 | 50/60 | 2,000 | 1,200 | 3,200 |
| 220 | 9.6 | 50/60 | 2,000 | 1,200 | 3,200 |
| 230 | 9.2 | 50/60 | 2,000 | 1,200 | 3,200 |
| 240 | 8.8 | 50/60 | 2,000 | 1,200 | 3,200 |

| | | |
|--------------------------------|-------------------|------------------|
| Blade Diameter | 235 mm (9-1/4") | |
| Arbor Diameter | 30 mm (1-3/16") | |
| Max. Cutting Capacities | At 90° | 85 mm (3-11/32") |
| | At 45° | 64 mm (2-1/2") |
| No Load Speed | 4,500 R/min. | |
| Net Weight | 7.6 kg (16.7 lbs) | |
| Power supply cord | 2.5m (8.2ft) | |

▶ Standard equipment

Carbide-tipped Saw Blade 235-20, Hex Wrench 6, Rip Fence (Guide Rule)

▶ Optional accessories

Joint Set (for connecting to the vacuum cleaner), Inner Flange 42 (for saw blade with 25 mm; 63/64" arbor diameter)