

# TECHNICAL INFORMATION



New Tool

**Models No.** ▶ 6017D

**Description** ▶ 10mm Cordless Drills

## CONCEPTION AND MAIN APPLICATIONS

These 7.2V cordless drills are redesigned versions of existing Model 6012D, 6015D, 6172D and their brief benefits are:

- \*Easy operation  
by ergonomic design for easily pushing the axis of drilling
- \*Very quiet
- \*Equipped with electric brake

Model	Speed control	Drill chuck	Battery	Fast charger	Charging time	Plastic Carrying case
6016DW	2 speeds (H&L)	Keyed	Battery 7000	DC7020	3Hr	No
6017D	2 speeds (H&L)	Keyless	N/A	N/A	N/A	No
6017DW			Battery 7000	DC9700 or DC7100	1Hr	Yes
6018D	+ variable speed	Keyless	N/A	N/A	N/A	No
6018DW			Battery 7000	DC9700 or DC7100	1Hr	Yes

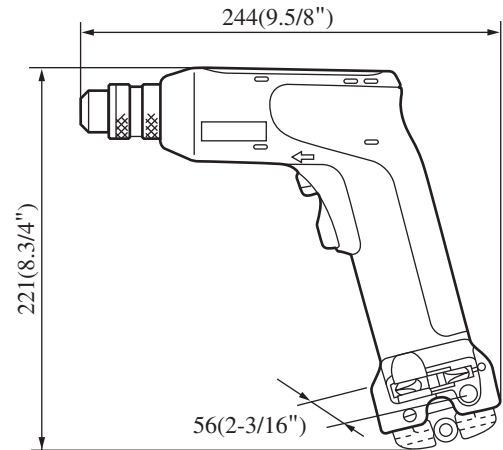

## ► Specifications

<b>Motor</b>		DC 7.2V magnet motor
<b>Battery</b>		Battery 7000(Ni-Cd, 7.2V, 1.3Ah)
<b>No load speed</b>	6016D	H:600rpm L:200rpm
	6017D	
	6018D	H:0-600rpm L:0-200rpm
<b>Chuck capacity</b>		1.0-10mm(1/32-3/8")
<b>Capacities</b>	Steel	10mm(3/8")
	Wood	15.4mm(5/8")
	Wood screw	5.1mm(13/64")X35mm(1-3/8")
<b>Max.fastening torque</b>	H	Approx.40Kgf-cm(35in-lbs)
	L	Approx.120Kgf-cm(104in-lbs)
<b>Net weight (including battery)</b>	6016D	1.0Kg(2.2lbs)
	6017D	1.0Kg(2.2lbs)
	6018D	1.1Kg(2.4lbs)

<Note>L: Low speed H : High speed

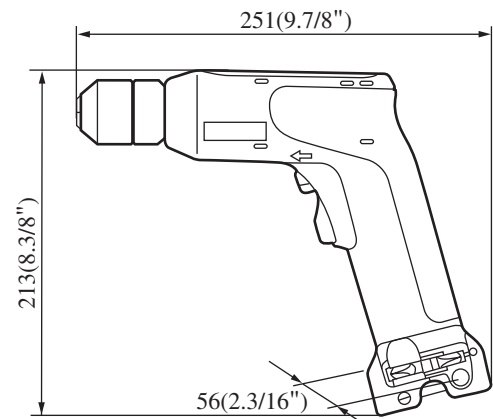

The standard equipment for the tools shown may differ from country to country.

## ► Standard equipment

	6016DW	6017D	6017DW	6018D	6018DW
+ Bit2-45 (2 pcs.)	Yes				
Battery Cover	Yes	No	Yes	No	Yes
Chuck Key	Yes	No			
Chaging Base	Yes	No			
Plastic Carrying Case	No		Yes	No	Yes

## ► Optional accessories

Drill Bit 1.5,2,3,4,5,6

Drill Bit for wood 9,12,15

Philips Bit 1-65, 2-45,2-65,2-82,2-110, 2-150,2-250,3-45,3-65,3-110

Slotted Bit 5-45,5-82,6-70,6.35-45,8-40,8-70

Foam Polishing Pad 125

Rubber Pad Assembly

Wool Bonnet 100

Fast Charger DC7100, DC9700, DC1201, DC1209

Automotive charger DC7112

## ► Repair

### (1) Cautions in disassembling

To replace the gear assembly, first disassemble the drill chuck.(To disassemble only the housing, its no need to disassemble the chuck.)

Use care not to miss the compression spring 4 inside the speed change lever since it can be easily jumped out when disassembling.

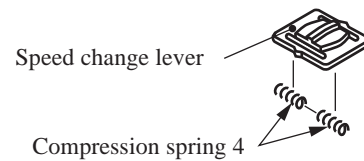

Figure 1

(2) Cautions in assembling

(a) Assembling of motor and gear assembly

\*Since the motor bracket is mounted on the gear assembly for repair, turn counterclockwise (viewed from motor bracket side) the motor bracket beforehand to disconnect it from the gear assembly.

- 1) Screw the motor bracket into the motor.
- 2) Turn clockwise (viewed from motor bracket side) the motor assembling parts (shown in 1) to mount them on the gear assembly. At this time assemble in a way that the red mark on the motor edge is placed on the change lever side of the gear assembly.

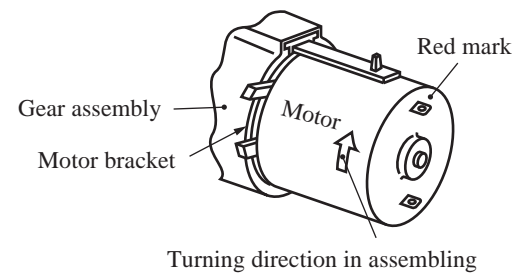

Turning direction in assembling

Figure 2

(b) Mounting of speed change lever

- 1) Mount the compression spring 4 on the speed change lever.
- 2) Mount the speed change lever on the protrusion of the change lever as shown on the figure 3 while using care so that the compression spring 4 may not be jumped out.

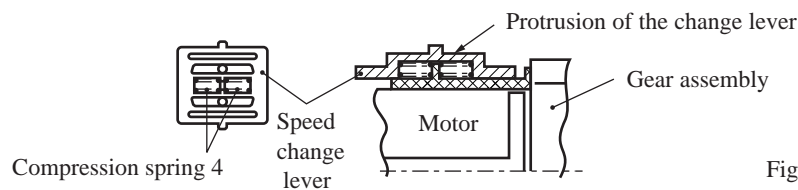

Figure 3

(c) Assembling on the housing

- 1) To assemble the one body of gear assembly and motor etc. on the housing L, place the speed change lever at the position as shown on the figure 4.
- 2) Use care that the compression spring 4 may not be jumped out in assembling on the housing.

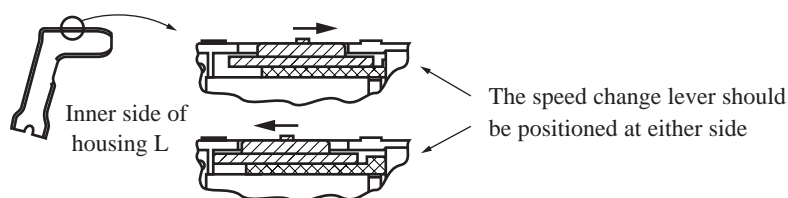

Figure 4

(d) Assembling of drill chuck

- 1) Fasten the chuck into the spindle and body face.
- 2) Mount the hexagon rod on the chuck and use the vice to fix the hexagon rod.
- 3) Set to the normal rotation and low speed. Use the full charged battery.
- 4) Insert the switch and fasten the chuck while securely holding the handle.  
\*Weakly holding the handle may let you turned around when motor locking.
- 5) Widen the claw of chuck at maximum and fasten the pan head screw for holding the chuck.  
\*The left hand thread is used for pan head screw.

► **Circuit drawing**

