

# T ECHNICAL INFORMATION

**Models No.** ▶ 6092D, 6092DW

**Description** ▶ MAKITA Cordless driver drill

## CONCEPTION AND MAIN APPLICATIONS

This machine is the Cordless driver drill equipped with the non-step variable speed switch and the brake, which is driven through the battery 9000 as the power source.

The 2-speed switching function by the gear allows the screw fastening and boring work for wide range.

The 6092D consists of :

6092D(MAKITA battery driver drill) ;

DC9000(MAKITA fast charger) ;

and battery 9000.

The 6092D is the model without battery and charger.

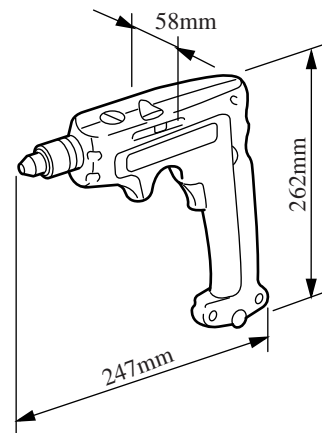

### ► Specifications

Voltage(V)	Current(A)	Frequency(Hz)	Consumed power(W)	Rated output(W)	Max. output(W)
9.6	-	-	-	-	-

<b>Motor</b>	DC 9.6 V Magnet motor
<b>No load speed</b>	0-1100/min. in high speed 0-400/min. in low speed
<b>Chuck capacity</b>	1.5-10
<b>Boring capacity</b>	10 mm for steel, 18 mm for wood
<b>Screwing capacity</b>	Wooden screw 5.5x55 mm
<b>Weight</b>	1.6 kg

### ► Standard equipment

Chuck key S10 --- One piece

+ Bit 2-65 --- One piece

### ► Optional accessories

Battery 9000, Drill 1.5, 2, 3, 4, 5, 6, Wooden drill 9, 12, 15, - bit 5-45, 5-82, 6-70, 6.35-45, 8-45, 8-70

+ Bit 1-65, 2-45, 2-65, 2-82, 2-110, 2-150, 2-250, 3-45, 3-65, 3-110,

Rubber pad assembly, Wool bonnet 100, Buff 125, 12V fast charger DC9012(for charging through the cigarette lighter socket of car)

### ► Repair

There is no special cautions for repair.