

# T ECHNICAL INFORMATION



New Tool

**Models No.** ▶ 6200D

**Description** ▶ 10 mm (3/8") Cordless Driver Drill

## CONCEPTION AND MAIN APPLICATIONS

T-shaped Cordless Driver Drill which is well balanced and thin-gripped for increased maneuverability.

Model 6200D/DW is more powerful and efficient than existing Model 6095D/DW as Model 6200D/DW is equipped with an improved motor.

Model 6200D is sold with battery cartridge but without fast charger.

Model 6200DW includes battery cartridge 9100 and fast charger DC9100.

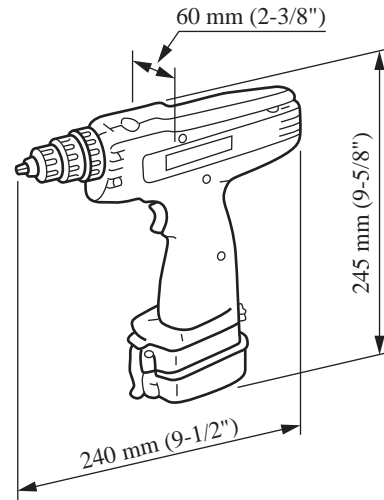

### ► Specifications

		DC Magnet Motor (9.6 V)
<b>No Load Speed</b>	<b>High</b>	0 - 1,100 R/min.
	<b>Low</b>	0 - 400 R/min.
<b>Capacities</b>	<b>Steel</b>	10 mm (3/8")
	<b>wood</b>	18 mm (11/16")
	<b>wood Screws</b>	5.8 mm (7/32") x 55 mm (2-3/16")
	<b>Machine Screws/Nuts</b>	6 mm (1/4")
<b>Max. Fastening Torque</b>	<b>At High Speed</b>	About 55 kg.cm (4.0 ft.lbs)
	<b>At Low Speed</b>	About 140 kg.cm (10.1 ft.lbs)
<b>Net Weight</b>		1.7 kg (3.8 lbs)

### ► Standard equipment

Phillips Bit 2-65

### ► Optional accessories

Drill Bit 1.5, 2, 3, 4, 5, 6 (for steel), Drill Bit 9, 12, 15 (for wood),  
 Slotted Bit 5-45, 5-82, 6-70, 6.35-45, 8-45, 8-70, Phillips Bit 1-65, 2-45,  
 2-65, 2-82, 2-110, 2-150, 2-250, 3-45, 3-65, 3-110, Socket Bit 5.5-55, 7-55,  
 8-55, 10-55, Rubber Pad Assembly, Wool Bonnet 100, Foam Polishing Pad 125,  
 Battery Cartridge 9100, 12V 1-hour Fast Charger DC9012 (Automotive Charger)

The standard equipment for the tools shown may differ from country to country.