

# TECHNICAL INFORMATION

**Makita**

New Tool

**Models No.** ▶ 6211D

**Description** ▶ 10 mm (3/8") Cordless Driver Drill

## CONCEPTION AND MAIN APPLICATIONS

Model 6211D/DW and Model 6311D/DW (described in NT-7/92) are identical except for the chuck capacity.

Model	Chuck Capacity
6211 D/DW	10 mm (3/8")
6311 D/DW	13 mm (1/2")

Model 6211D is sold with a battery cartridge 1200 but without a fast charger.

Model 6211DW includes a battery cartridge 1200 and a fast charger DC 1200.

(Note)

Model 6211DW for USA and Canada includes a fast charger DC1290 instead of DC1200.

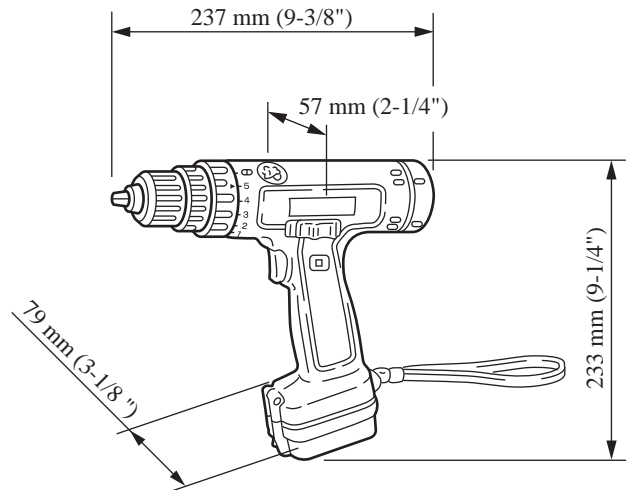

### ► Specifications

		DC Magnet Motor (12 V)
<b>No Load Speed</b>	High	0 - 1,150 R/min
	Low	0 - 370 R/min.
<b>Capacities</b>	Steel	10 mm (3/8")
	wood	21 mm (13/16")
	wood Screws	6.4 mm (1/4") x 55 mm (2-3/16")
	Machine Screws/Nuts	6 mm(1/4")
<b>Max. Fastening Torque</b>	At High Speed	About 65 kg.cm (4.7 ft.lbs)
	At Low Speed	About 210 kg.cm (15.2 ft.lbs)
<b>Net Weight</b>		1.8 kg (3.7lbs)

### ► Standard equipment

Phillips Bit 2-65, Carrying Hook, Plastic Carrying Case (6211DW only)

### ► Optional accessories

Battery Cartridge 1200, Various size of Drill Bits, Various size of Slotted Bits, Various size of Phillips Bits, Various size of Socket Bits, Foam Polishing Pad 125, Wool Bonnet 100, Rubber Pad Assembly, Fast Charger DC1200, Plastic Carrying case

The standard equipment for the tools shown may differ from country to country.