

# T ECHNICAL INFORMATION



New Tool

**Models No.** ▶ 6214D

**Description** ▶ Cordless Driver Drills

## CONCEPTION AND MAIN APPLICATIONS

Model 6214D is 12V 10mm cordless driver drill, which is efficient for driving approx.40mm wood screw and drilling approx.9mm hole in wood. Its brief benefits are ;

- \*Compact design
  - \*Light weight
  - \*Equipped with electric brake
  - \*Longer life motor by replacing carbon brushes
- Model 6314D is 13mm version of model 6214D.

Model	Battery	Fast Charger	Plastic Carrying Case
6214/6314DA	1222(Ni-Cd)	No	No
6214/6314DWA	1222(Ni-Cd)	DC1411	Yes
6214/6314DWAE	1222(Ni-Cd)X2	DC1411	Yes
6214/6314DWBE	1222(Ni-MH)X2	DC1411	Yes

### ► Specifications

<b>Motor</b>		DC 12V magnet,motor	
<b>Battery</b>		Battery 1222 Ni-Cd,12V,2.0Ah) Battery 1223 Ni-MH,12V,2.2Ah)	
<b>No load speed</b>		High:0-1100rpm Low:0-350rpm	
<b>Chuck capacity</b>		<b>6214D</b>	0.8mm(1/32")-10mm(3/8")
		<b>6314D</b>	1.5mm(1/16")-13mm(1/2")
<b>Max.drilling capacities</b>	<b>6214D</b>	<b>Steel</b>	10mm(3/8")
		<b>Wood</b>	24mm(15/16")
	<b>6314D</b>	<b>Steel</b>	13mm(1/2")
		<b>Wood</b>	24mm(15/16")
<b>Max.driving capacities</b>	<b>Wood screw</b>		6.4mm(1/4")x55mm(2-3/16")
	<b>Machine screw,Nut</b>		6mm(1/4")
<b>Setting of fastening torque</b>		16 stages+drill-mode	
<b>Declutching torque</b>		0.5-5N·m (0.4-3.6ft·lbs) (5-50Kgf·cm)	
<b>Max.fastening torque(drill-mode)</b>	<b>High Speed</b>	7N·m(5.1ft·lbs)(70Kgf·cm)	
	<b>Low speed</b>	21N·m(15.2ft·lbs)(210Kgf·cm)	
<b>Net weight</b>		1.7Kg(3.2lbs)	

### ► Standard equipment

- Philips Bit 2-65 ----- 1 pc.
  - Battery Cover ----- 1 pc.
  - Set Plate -----1 pc.
  - Plastic Carrying Case -----1 pc. (except Model 6214/6314DA)
- <Note>The standard equipment may differ country to country.

### ► Optional accessories

- Drill Bit 1.5,2,3,4,5,6                      Drill Bit for wood 9,12,15
- Philips Bit 1-65,2-45,2-65,2-110,2-150,2-250,3-45,3-65,3-110
- Slotted Bit 5-45,5-82,6-70,6.35-45, 8-45,8-70
- Socket Bit 7-55,8-55,10-55
- Foam Polishing Pad 125                      Rubber Pad Assembly                      Wool Bonnet 100
- Battery 1200, 1202, 1202A, 1220, 1222,1233
- Fast Charger DC1411,DC1209 (European countries only)
- Fast Automotive Charger DC1412                      Holster

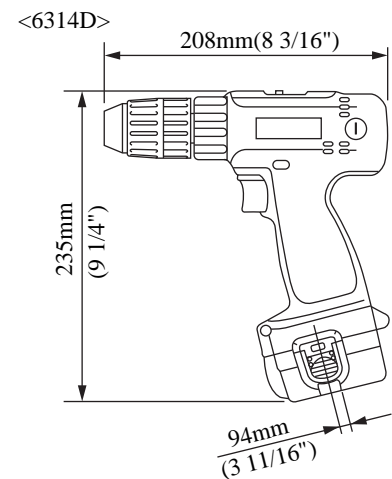
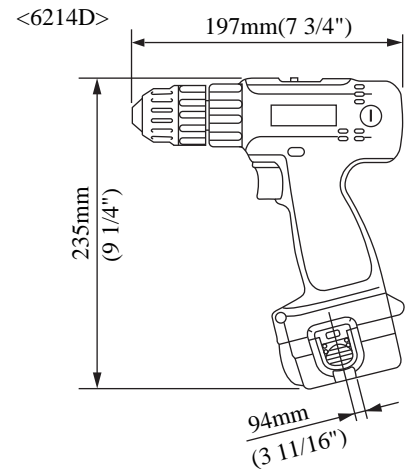

The standard equipment for the tools shown may differ from country to country.

## ► Repair

### (1) Cautions in assembling

To replace the gear assembly, first disconnect the drill chuck.(If the housing only is disassembled, its no need to disconnect the chuck.) Use care not to miss the compression spring 4 inside the speed change lever since it can be easily jumped out when disassembling.

### (2) Cautions in assembling

#### (a) Assembling of the motor and gear assembly

\*As the motor bracket is mounted on the gear assembly for repair, turn the motor bracket counterclockwise(viewed from the motor bracket side) to remove it from the gear assembly.

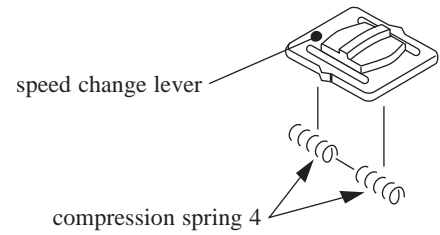

Figure 1

1) Screw the motor bracket into the motor.

2) Turn the motor assembling parts shown in 1) in clockwise(viewed from the motor bracket side) to assemble them on the gear assembly.

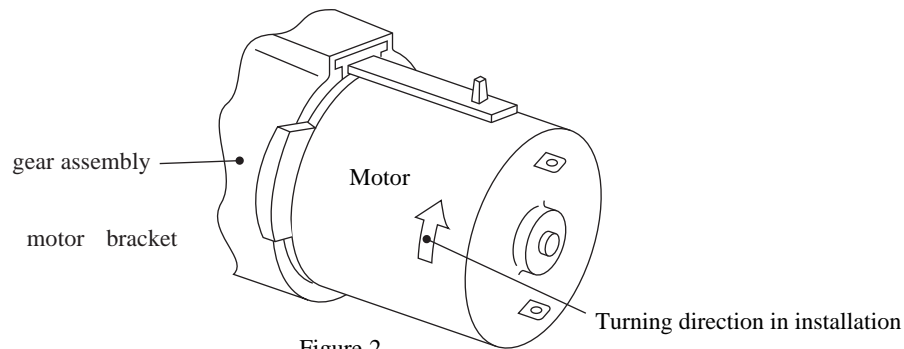

Figure 2

#### (b) Assembling of the leaf spring

Assemble the leaf spring on the housing L as shown on the figure 3.

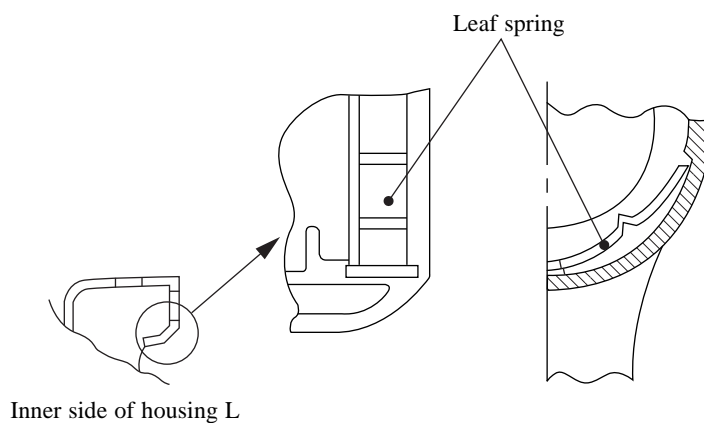

Figure 3

(c) Assembling of the speed change lever

- 1) Set the two pieces of compression spring 4 in the speed change lever.
- 2) Assemble the speed change lever assembly on the protrusion of the change lever as shown on the figure 4 while using care that the compression spring 4 may not jump over.

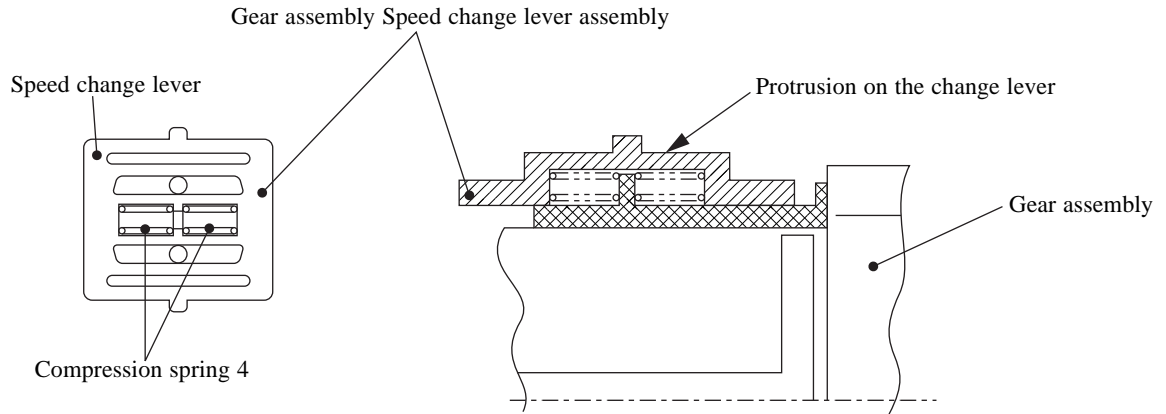

Figure 4

(d) Assembling on the housing

- 1) To assemble the one body of gear assembly and motor etc. on the housing L, place the speed change lever on the position shown on the figure 5.

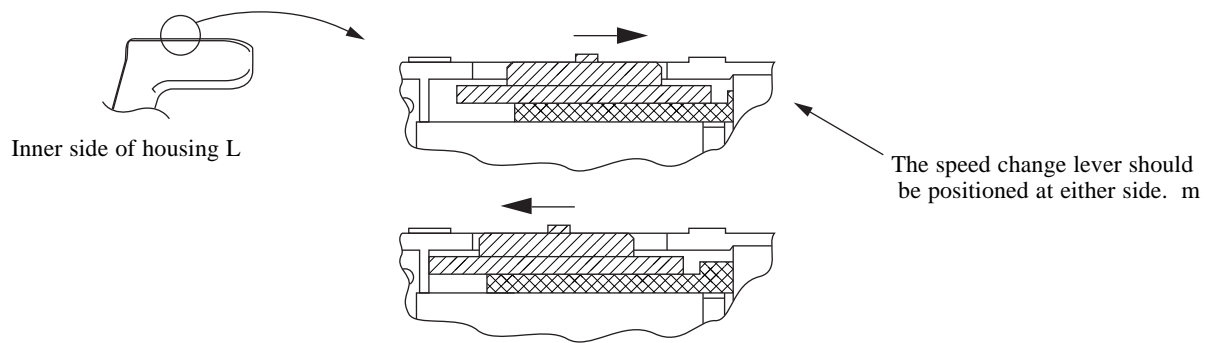

Figure 5

(e) Assembling of the chuck

- 1) Place the chuck on the spindle face.
- 2) Mount the hexagon rod spanner on the chuck and use the vice to fix them.
- 3) Set to the drill mode, normal turning and low speed.
- 4) Set the full charged battery and securely hold the handle.\*1
- 5) Allow the trigger to full speed in about 1 second while no impact is adding.  
\*Insufficiently holding the handle may cause the handle to turn around in locking. This machine is going to turn clockwise.
- 6) Widen the claw of chuck at maximum and then fasten the screw for holding the chuck.  
\*The left-handed screw is used.

► **Circuit drawing**

