

For Models ▶ 6222D

Description ▶ Cordless Driver Drill

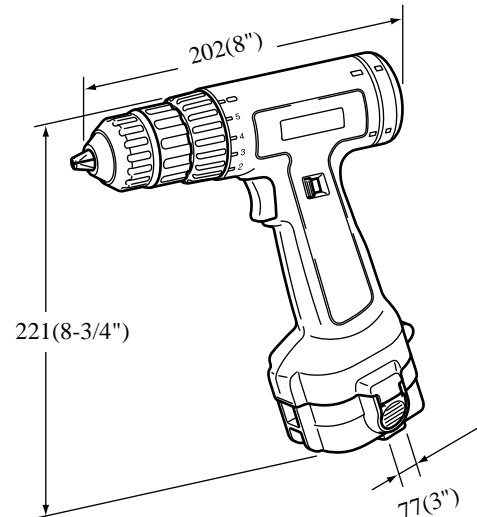

CONCEPTION AND MAIN APPLICATIONS

9.6 V Driver drill based on 6221D, by changing the battery to New push button system one. Like 6221D, there is no gear change, but good operativity because of best setting of rotation and torque.

Model	Battery	Charger	Plastic case
6222D	9120...1pc	No	No
6222DWE	9120...2pc	DC9700	Yes

Model 6222D will not be produced for the time being.

Besides, these models are only for export and manufactured by MCC.

► Specifications

Motor		Direct current magnet motor HC683LG-63728
Battery		NiCad Battery 9120(9.6V 1.3Ah)
Current		Direct current 9.6 V
Speed at no load		0~700 R/min
Chuck capacity		0.8~10mm
Drilling capacity	Iron works	10mm
	Wood works	18mm
Screwing capacity		Wood screw 5.1x35 mm Machine screw and Nut 6 mm
Max. tighten torque		approx. 80kgf•cm
Clutch driven torque		10 15 20 30 45 kgf•cm

► Standard equipment

Battery 9120...2 pcs

Battery cover...2 pcs

⊕ Bit 2-45...1 pc

► Optional accesories

Drill 1.5, 2,3,4,5,6, Auger 9,12,15

⊖ Bit 5-45,5-82, 6-70, 6.35-45, 8-45, 8-70

⊕ Bit 1-65, 2-45, 2-65, 2-82, 2-110, 2-150, 2-250, 3-45, 3-65, 3-110

Socket bit 7-55, 8-55, 10-55 Buff 125

Rubber pad assembly, Wool bonnet 100

Battery 9120, 9122 Quick charger DC9700, DC1290, DC1201, DC1410

9-minute quick charger DC1209

Quick car charger DC 1412

▶ **Capacity**

Same as 6221D

▶ **Repair**

Same as 6220D