

T ECHNICAL INFORMATION



New Tool

Models No. ▶ 6223D

Description ▶ Cordless Driver Drill

CONCEPT AND MAIN APPLICATIONS

Model 6223D is the 12V version of the existing Model 6222D and its brief benefits are;

- *Battery 1220 (12v) can be removed easily by pushing buttons.
- *Number of driving screws from a single charge are much increased.
- *Equipped with electric brake

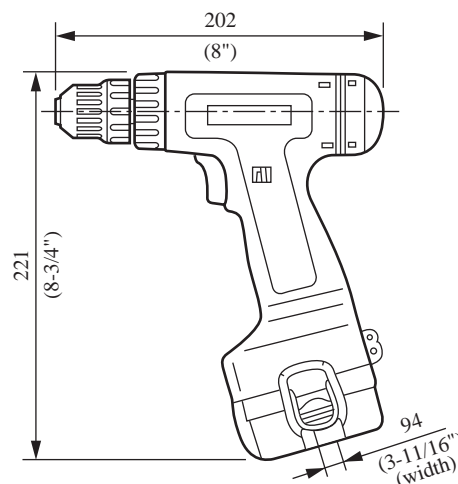

| Model | Battery | Fast Charger | Plastic Carrying case |
|---------|-----------------|--------------|-----------------------|
| 6223D | Battery 1220 X1 | No | No |
| 6223DW | Battery 1220 X1 | DC1290 | Yes |
| 6223DWE | Battery 1220 X2 | DC1290 | Yes |

▶ Specifications

| | | |
|----------------------------------|--------------------------------|----------------------------|
| Motor | DC 12V magnet motor | |
| Battery | Battery 1220 (Ni-Cd,12V,1.3Ah) | |
| No load speed | 0-700rpm | |
| Chuck capacity | 0.8-10 mm (1/32-3/8") | |
| Max.drilling capacities | Steel | 10 mm(3/8") |
| | Wood | 15 mm (5/8) |
| Max. fastening capacities | Wood screw | 5. 1mmX35mm(13/64"X1-3/8") |
| | Machine screwNut | 6 mm (1/4") |
| Max. fastening torque | 100 Kgf·cm(87inch·lbs) | |
| Net weight | 1.5Kg(3.3lbs) | |

▶ Standard equipment

- + Bit 2-65 ----- 1 pc.
 - Set Plate ----- 1 pc.
 - Fast Charger DC1290 -----1 pc.
 - Battery 1220 -----2 pcs. (6223DWE)
 - Battery Cover ----- 2 pcs. (6223DWE)
 - Plastic Carrying Case ----- 1 pc.
- <Note>The standard equipment for the tool may differ from country to country.

The standard equipment for the tools shown may differ from country to country

► **Optional accessories**

Drill Bit 1.5,2,3,4,5,6

Drill Bit for wood 9,12,15

Slotted Bit 5-45,5-82,6-70,6.35-45, 8-45,8-70

Philips Bit 1-65,2-45,2-65,2-82,2-110,2-150,2-250,3-45,3-65,3-110

Socket Bit 7-55,8-55,10-55

Foam Polishing Pad 125

Rubber Pad Assembly

Wool Bonnet 100

Battery 1220, 1200

High Capacity Battery 1222,1202,1202A

Fast Charger DC1290, DC1201, DC1410, DC1209

Fast Automotive Charger DC1412