

# TECHNICAL INFORMATION



**Models No.** ▶ 6226D, 6227D, 6228D

**Description** ▶ Cordless Driver Drill

## CONCEPTION AND MAIN APPLICATIONS

6226D/ 9.6V : 2 speed mechanic & variable speed control version of the existing Mod.6222D.

6227D : 12 V version of Mod.6226D

6228D : 14.4V version of Mod.6226D

The variation of these models are as follows.

Model No.	Battery	Charger	Torch light
6226DW	9120 : 1 pc.	DC9710	
6226DWE	9120 : 2 pcs.	DC9710	
6226DWLE	9120 : 2 pcs.	DC9710	Yes
6226DWBE	9133 : 2 pcs.	DC1411	
6227DW	1220 : 1 pc.	DC1470	
6227DWE	1220 : 2 pcs.	DC1470	
6227DWLE	1220 : 2 pcs.	DC1470	Yes
6227DWBE	1233 : 2 pcs.	DC1411	
6228DW			
6228DWE	1420 : 2 pcs.	DC1470	
6228DWLE	1420 : 2 pcs.	DC1470	Yes
6228DWBE	1433 : 2 pcs.	DC1411	

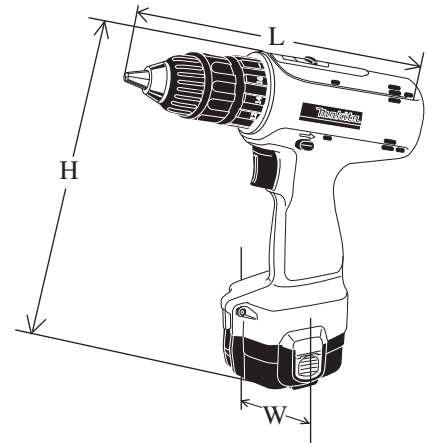

Dimensions

	6226D	6227D	6228D
L	210mm 8-1/4"	210mm 8-1/4"	210mm 8-1/4"
H	235mm 9-1/4"	235mm 9-1/4"	240mm 9-7/16"
W	77mm 3"	94mm 3-11/16"	94mm 3-11/16"

## ► Specification

Model No.		6226D	6227D	6228D
Voltage		9.6 V	12 V	14.4 V
No load speed (min. = rpm.)	High speed	0 - 1,100		
	Low speed	0 - 350		
Chuck ability		0.8mm (1/32") - 10mm (3/8")		
Capacities	in Steel	10mm (3/8")	10mm (3/8")	10mm (3/8")
	in Wood	21mm (13/16")	24mm (15/16")	24mm (15/16")
	Screw	5.1mm x 38mm (3/16" x 1-1/2")	5.1mm x 63mm (3/16" x 2-1/2")	5.1mm x 63mm (3/16" x 2-1/2")
Max tightening torque	High speed	6Nm (53.1 in lbs)	7Nm (62.0 in lbs)	7Nm (62.0 in lbs)
	Low speed	19Nm (168.2 in lbs)	22Nm (194.8 in lbs)	22Nm (194.8 in lbs)
Reversible action switch		Yes	Yes	Yes
Electric brake		Yes	Yes	Yes
Torque adjustment		16 stage and drill mode		
Net weight		1.4 Kg (3.1 lbs)	1.5 Kg (3.3 lbs)	1.6 Kg (3.5 lbs)

## ► Standard equipment

+ - Bit 2-65

Battery cover

Carrying case

< Note > The standard equipment for the tool shown may be differ from country to country.

## ► Optional accessories

Wool bonnet, Various drill bits for wood and metal, Various philips bits, slotted bits, socket bits,

Rubber pad assembly, Buff 125

Set plate for battery 9100, 9102, 9102A, 1200, 1202, 1202A

Charger DC9710, DC2101, DC1411, DC1422, DC1439, DC1801

Batteries

for 6226D	9100, 9102, 9102A, 9120, 9122, 9133
for 6227D	1200, 1202, 1202A, 1222, 1233
for 6228D	1420, 1422, 1433

## ► Repair

### (1) Removing gear assembly

Take off drill chuck first.

Be careful that compression spring 4 does not go out from speed change lever, when removing gear assembly from housing.

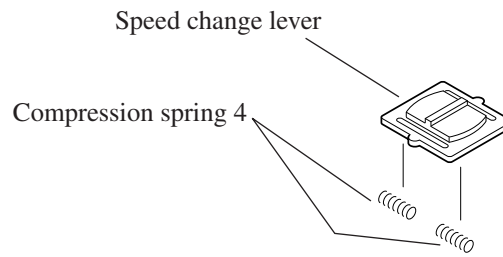

Fig. 1

### (2) Assembling

#### 1. Assembling motor and gear assembly

1) Motor bracket is, in advance, assembled to gear assembly for spare parts.

Remove the motor bracket from gear assembly by turning anti-clockwise.

And fasten motor bracket to motor with screw. See Fig.2.

2) Assemble motor equipped with motor bracket to gear assembly by turning clockwise. See Fig.2.

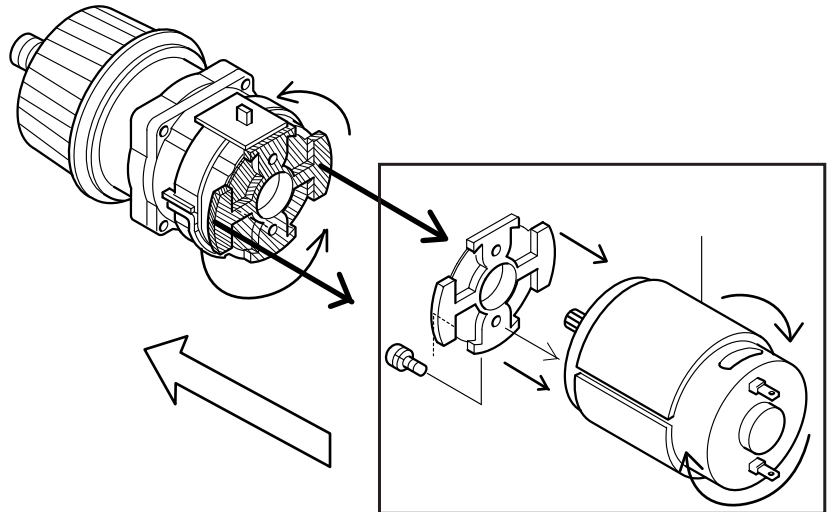

Fig. 2

#### 2. Assembling leaf spring

Assemble leaf spring to housing L as illustrated in Fig.3.

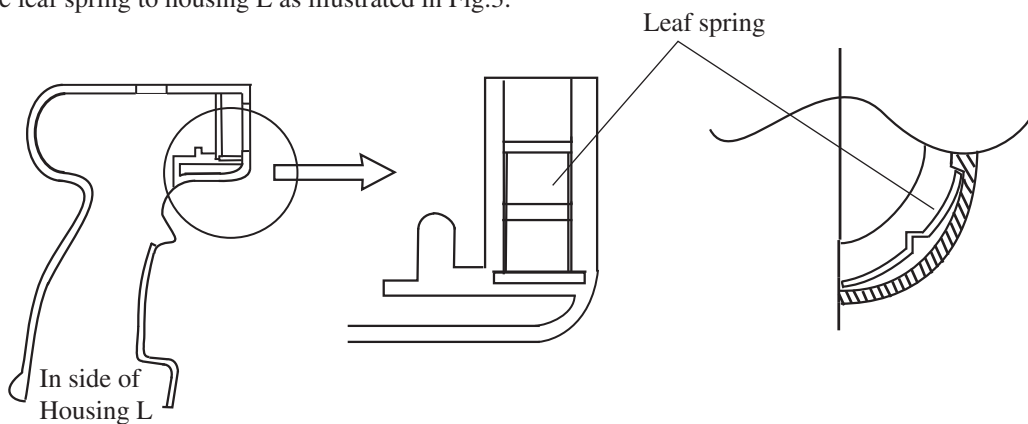

Fig. 3

## ► Repair

### 2. Installing of Speed change lever

- 1) Place two Compression spring 4s into Speed change lever as illustrated in Fig.4.

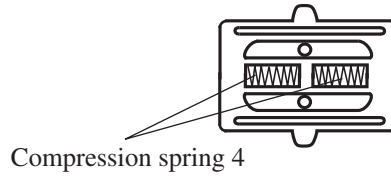

Fig. 4

- 2) Being careful that compression spring 4 may not comes out , install speed change lever assembly on the projection of change lever as shown in Fig. 5.

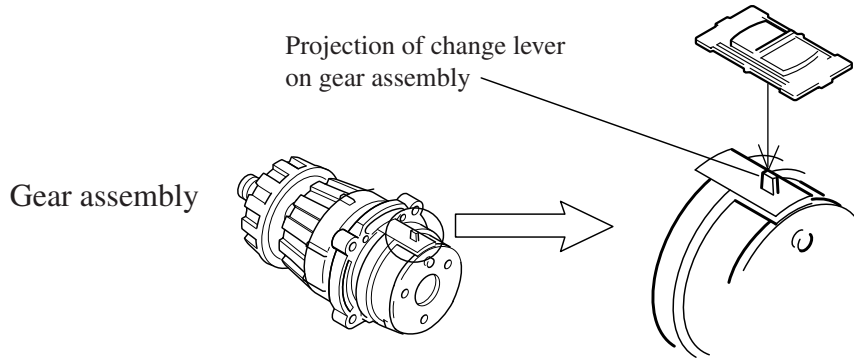

Fig. 5

### 3 Assembling to Housing

- 1) When attaching a unit of gear assembly and motor, etc. to housing L, place speed change lever in the position as shown in Fig. 6.

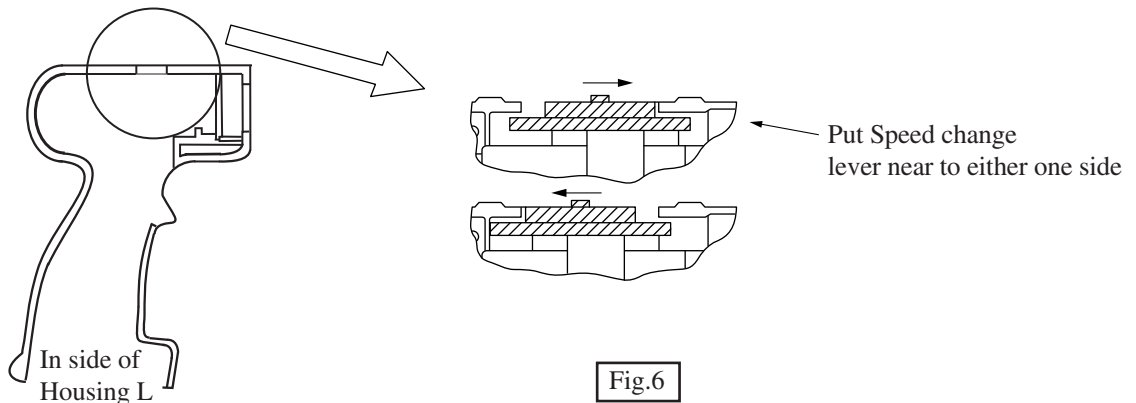

Fig.6

### 4 Assembling drill chuck

- 1) Set drill chuck on spindle, and fasten a hex bar with chuck.
- 2) Hold the machine with vise as illustrated in Fig.7.
- 3) Adjust the switch or lever as follows.
  - Speed change lever : Low speed **I**
  - Reversible switch : Clockwise rotation
  - Adjusting ring : Drill mode **<**
- 4) Attach full charged battery to the machine, and hold the grip firmly.
- 5) Operate the machine adjusted as 1) - 4) with full speed for approx. one second. At this time you have to hold the machine so strong that you can withstand the shock by spindle lock.
- 6) Open the three jaws of chuck fully, and fasten pan head screw M5x22 anti-clockwise firmly.

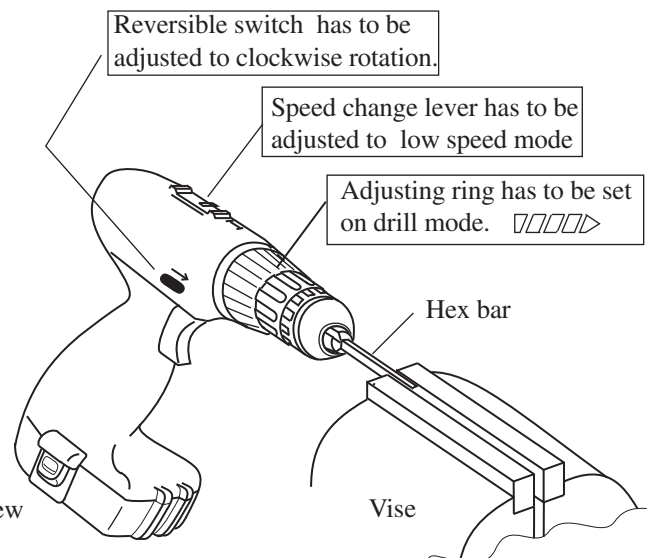
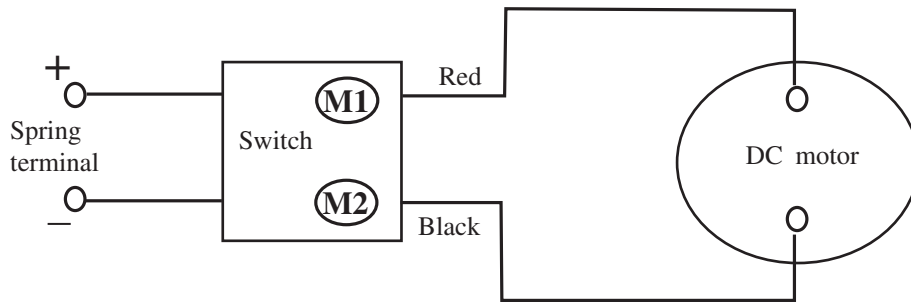

Fig.7

## ► Circuit diagram



## ► Wiring diagram

Lead wires have to be set as illustrated in Fig.C, paying attention to the following matters.

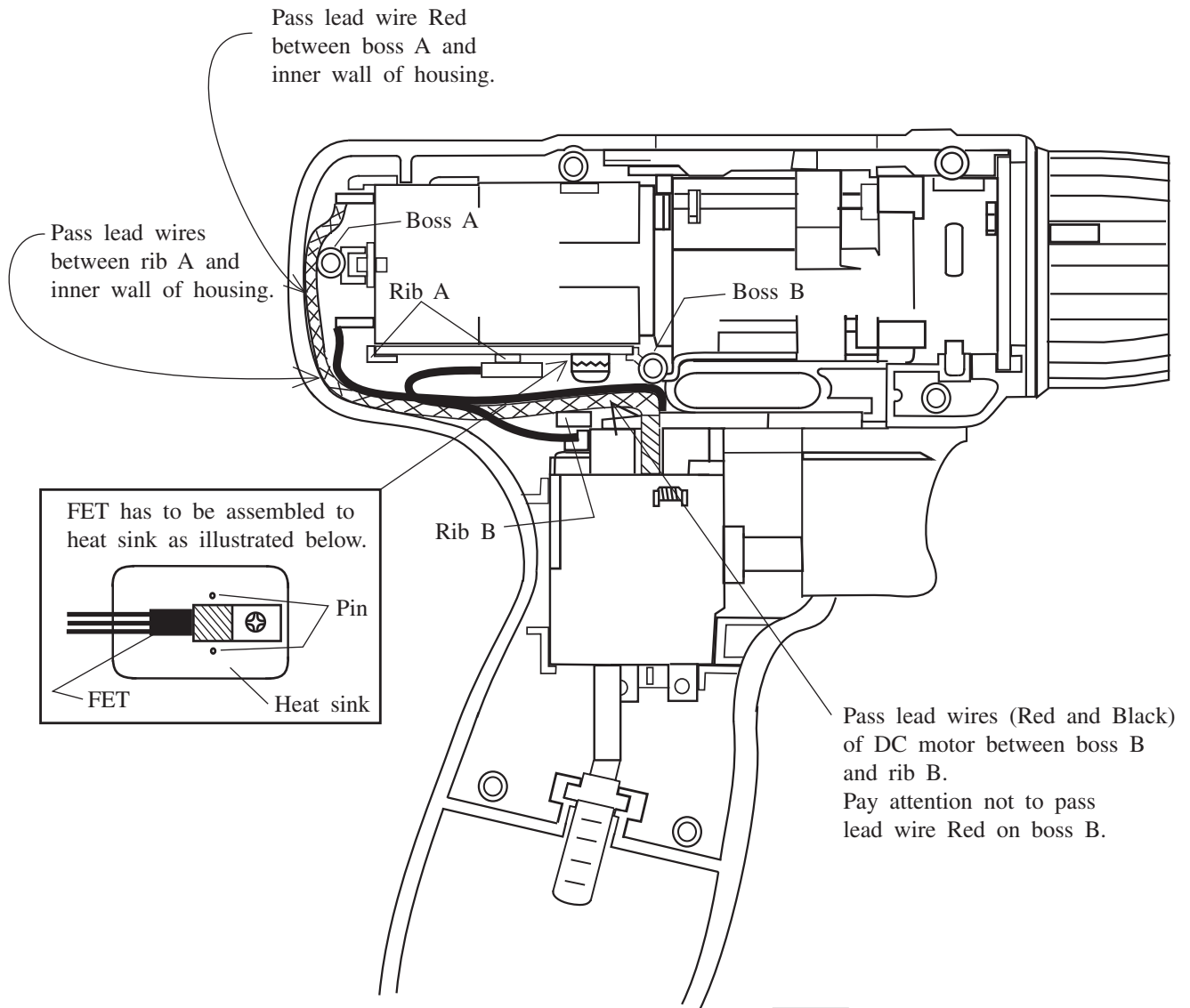

Fig.C