

# T ECHNICAL INFORMATION

**Makita**

PRODUCT

P 1 / 7

Models No. ▶ 6281D

Description ▶ 14.4V Cordless Driver Drill 10mm (3/8")

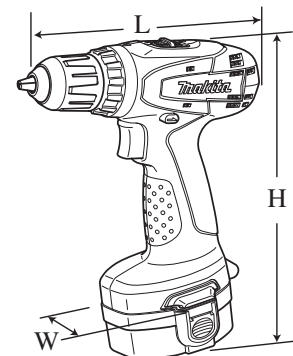

## CONCEPT AND MAIN APPLICATIONS

Model 6281D has been developed as the successor model of 6280D, featuring:

- Single sleeve keyless drill chuck for easy bit installation/removal
- New tool design

Model 6281D is available in the following variations.

Model No.	Battery		Battery cover	Charger	Rechargeable flashlight	Plastic carrying case
	type	quantity				
6281DZ	No	---	No	No	No	No
6281DW	1420 (Ni-Cd 1.3Ah)	1	1	DC1414	No	Yes
6281DWE		2	2		ML140	
6281DWLE						
6281DWAE	1422 (Ni-Cd 2.0Ah)	2	2	DC1414	No	Yes
6281DWALE					ML140	
6281DWPE	PA14 (Ni-Cd 1.3Ah)	2	2	DC1414	No	Yes
6281DWPLE					ML140	

Dimensions: mm (")	
Length (L)	192 (7-9/16)
Width (W)	95 (3-3/4)
Height (H)	240 (9-1/2)

Also, the models include the accessory listed in "Standard equipment".

## ► Specification

Battery	Voltage:	14.4
	Capacity: Ah	1.3/ 2.0/ 2.6
	Cell	Ni-Cd/ Ni-Cd/ Ni-MH
Max output: W		180
No load speed: min-1=rpm	High	0 - 1,300
	Low	0 - 400
Capacity of drill chuck: mm (")		0.8 - 10 (1/32 - 3/8)
Capacity: mm (")	Steel	10 (3/8)
	Wood	25 (1)
Torque setting		16 stage + drill mode
Clutch torque setting: N.m (in.lbs)		1.0 - 4.0 (9 - 35)
Lock torque: N.m (in.lbs)		30 (260)
Max. fastening torque: N.m (in.lbs)	Hard joint	36 (320)
	Soft joint	20 (180)
Electric brake		Yes
Mechanical speed control		Yes (2 speed)
Variable speed control		Yes
Reverse switch		Yes
Net weight [with Battery 1420]: kg (lbs)		1.6 (3.5)

## ► Standard equipment

+ Bit 2-65 (double-end) ..... 1 pc

**Note:** The standard equipment for the tool shown above may differ by country.

## ► Optional accessories

Battery 1420

Battery 1422

Battery 1434

Battery 1435

Battery 1435F

Battery PA14

Charger DC1414

Charger DC1804

Fast charger DC1439

Automotive charger DC1822

Drill bits for wood

Drill bits for steel

Driver bits

## ► Repair

**CAUTION: Remove the battery and the bit from the machine for safety before repair/ maintenance in accordance with the instruction manual!**

### [1] NECESSARY REPAIRING TOOLS

Description	Use for
Hex wrench 8	Removing / Installing Drill chuck
Plastic hammer	Removing Drill chuck

### [2] LUBRICATIONS

The components of Gear ass'y has been lubricated in Makita plant and assembled under strict quality control. Therefore, it is recommended to replace Gear ass'y without disassembling in repair.

### [3] DISASSEMBLY/ASSEMBLY

#### [3]-1. Keyless Drill Chuck

**Note:** When replacing Gear ass'y, begin by removing Keyless drill chuck.

As long as the repairing does not concern Gear ass'y, it is not necessary to remove Keyless drill chuck.

#### DISASSEMBLING

- (1) Remove M6x22 Flat head screw. (**Fig. 1**)
- (2) Preset the machine as illustrated in **Fig.2**.
- (3) Hold the machine firmly and pull the switch trigger slowly and carefully.

**Note:** 1) Pay attention that the machine except Keyless drill chuck starts revolving with strong force. Do not pinch your hand between the moved machine and Vise in this step.

- 2) If it is impossible to remove Keyless drill chuck, use 1R359 (Chuck removing tool) to remove it. Refer to Makita repair tool list.

**Fig. 1**

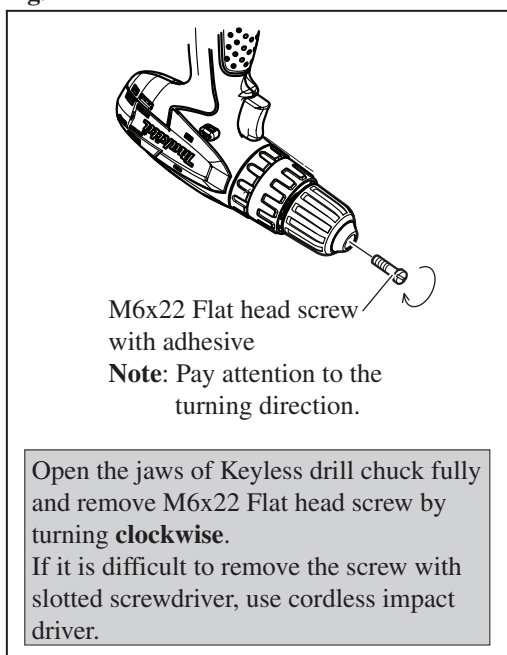

**Fig. 2**

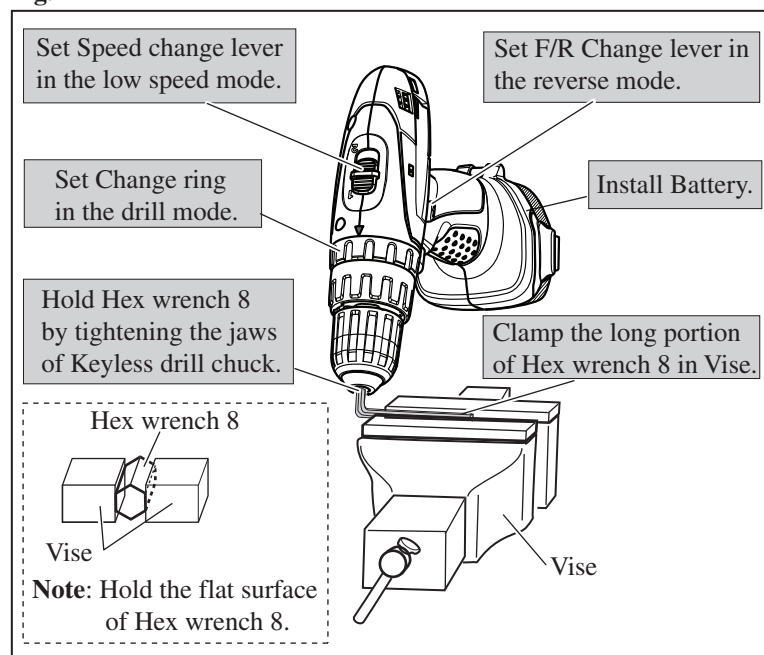

#### ASSEMBLING

- 1) Turn Keyless drill chuck clockwise until it sits on the end of the threaded portion of Spindle.
- 2) Fix the short portion of Hex wrench 8 to Drill chuck, and clamp the long portion of Hex wrench 8 in Vise.
- 3) Set Speed change lever in the low speed mode and F/R change lever in the Forward (clockwise) rotation mode. Then Install Battery.
- 4) Hold the machine firmly and pull the switch trigger to rotate Spindle until the motor is locked.
 

**Note:** Pull the switch trigger so that Spindle reaches full speed in one second.

**Important:** Be sure to release the switch trigger just after Spindle is locked.
- 5) Secure Keyless drill chuck with M6x22 Flat head screw by turning **counterclockwise** with impact driver.
 

**Note:** If you reuse the removed M6x22 Flat head screw, apply adhesive (ThreeBond 1321B/ 1342, Loctite 242) to the threaded portion. Makita genuine M6x22 Flat head screw for securing Keyless drill chuck is threadlocker screw.

► **Repair**

**[3] DISASSEMBLY/ASSEMBLY**

**[3]-2. Gear Ass'y, DC Motor**

**DISASSEMBLING**

- (1) Remove Keyless drill chuck.
- (2) Gear ass'y and DC Motor can be disassembled in the order of **Figs. 3, 4, 5, 6 and 7.**

**Fig. 3**

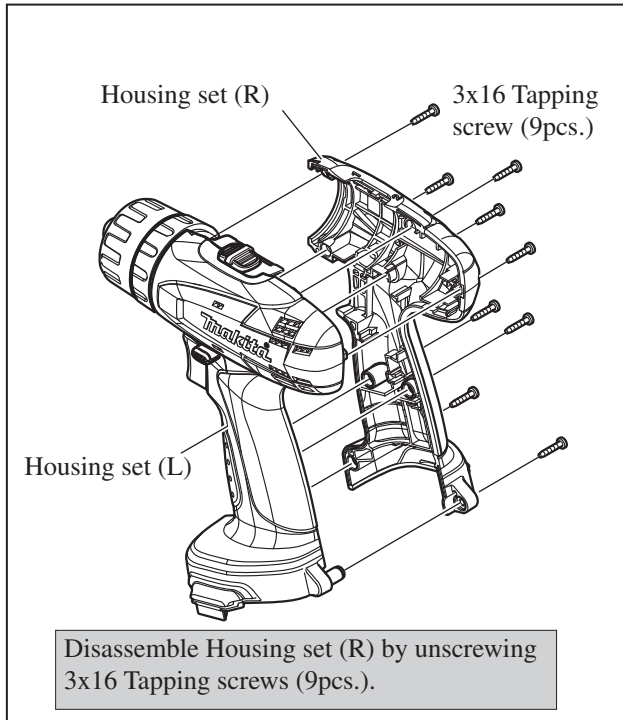

**Fig. 4**

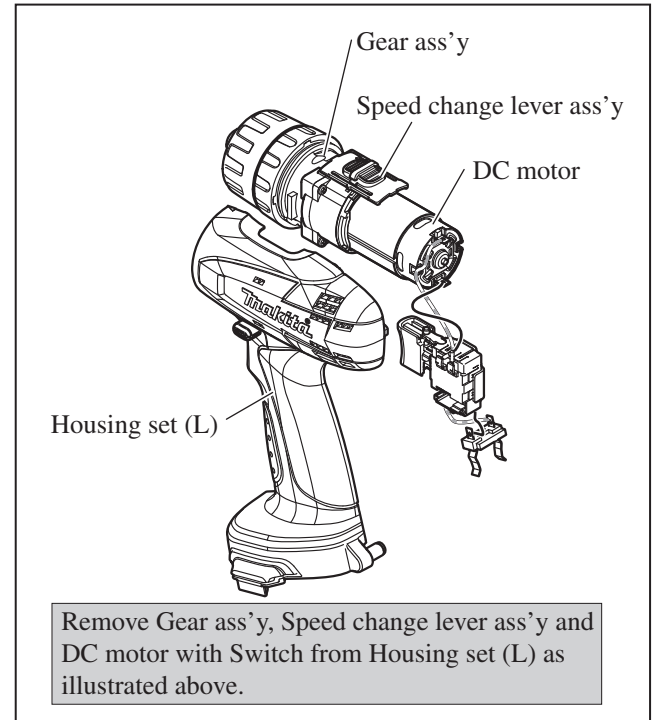

**Fig. 5**

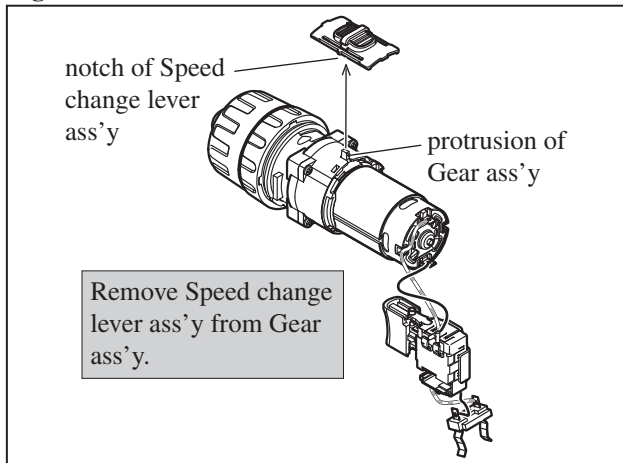

**Fig. 6**

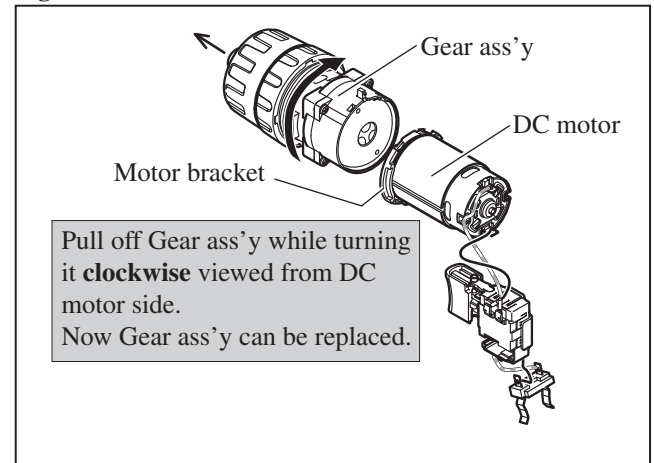

**Fig. 7**

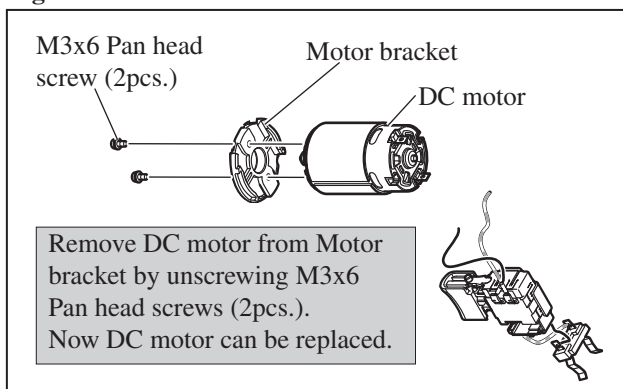

## ► Repair

### [3] DISASSEMBLY/ASSEMBLY

#### [3]-2. Gear Assembly, DC Motor

##### ASSEMBLING

The following portions of DC motor, Motor bracket and Gear ass'y have to face the same side. (Fig. 8)

- \* Red point mark (designated as plus terminal) on DC Motor
- \* None of protrusion side of Motor bracket
- \* Gear assembly's protrusion

Fig. 8

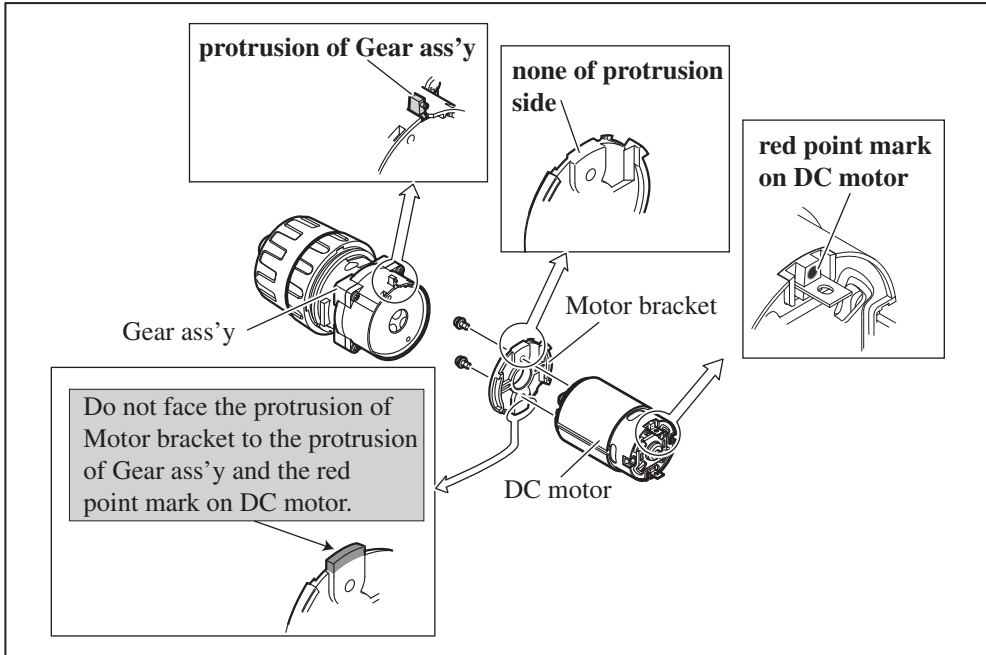

#### [3]-3. Speed Change Lever

##### ASSEMBLING

- (1) When assembling Speed change lever ass'y, make sure two Compression springs are assembled to its bottom in advance. (Fig. 9)
- (2) Fit the protrusion of Gear ass'y into Compression spring 4 in Speed change lever ass'y. (Fig. 10)
- (3) After mounting, set Speed change lever ass'y to low speed mode or high speed mode. (Fig. 11)

Fig. 9

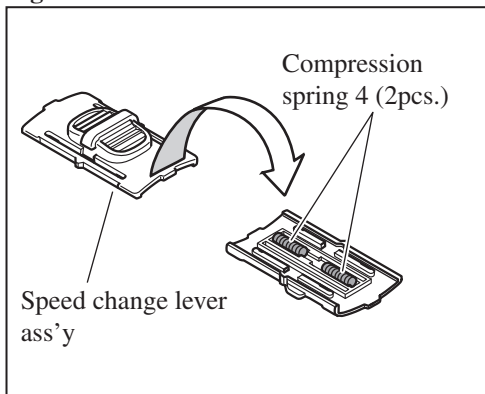

Fig. 10

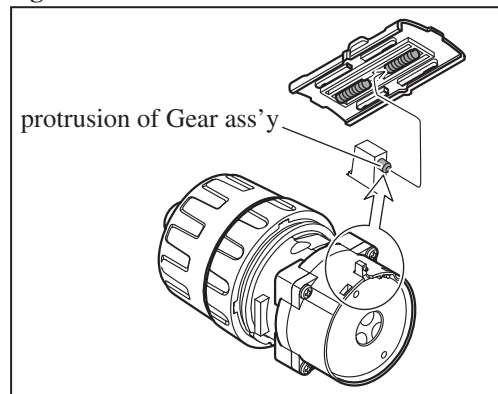
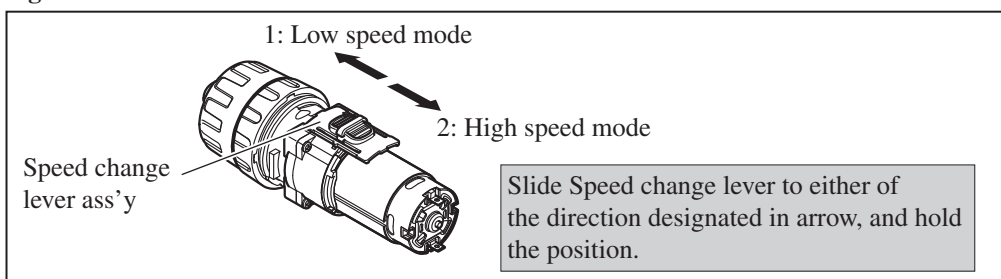

Fig. 11



► **Repair**

**[3] DISASSEMBLY/ASSEMBLY**

**[3]-4. Leaf Spring**

ASSEMBLING

Before assembling Gear ass’y and DC motor, Leaf spring has to be mounted to Housing set (L) as illustrated in **Fig. 12**.

**Fig. 12**

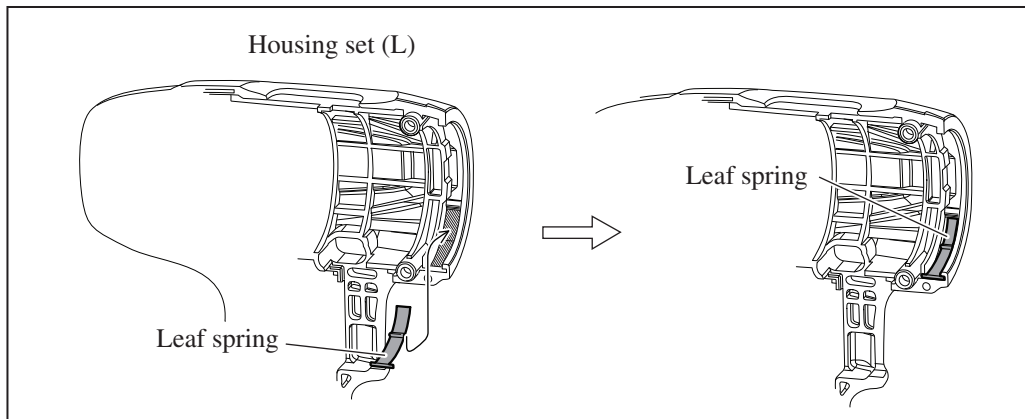

**[3]-5. F/R Change Lever**

ASSEMBLING

F/R Change lever can be assembled to Switch as illustrated in **Fig. 13**.

**Fig. 13**

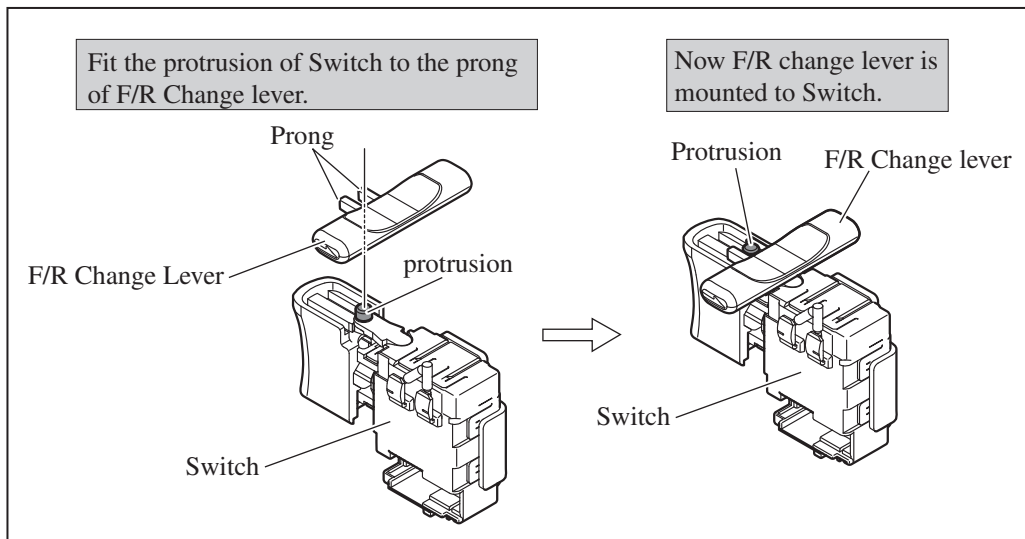

► **Circuit diagram**

**Fig. D-1**

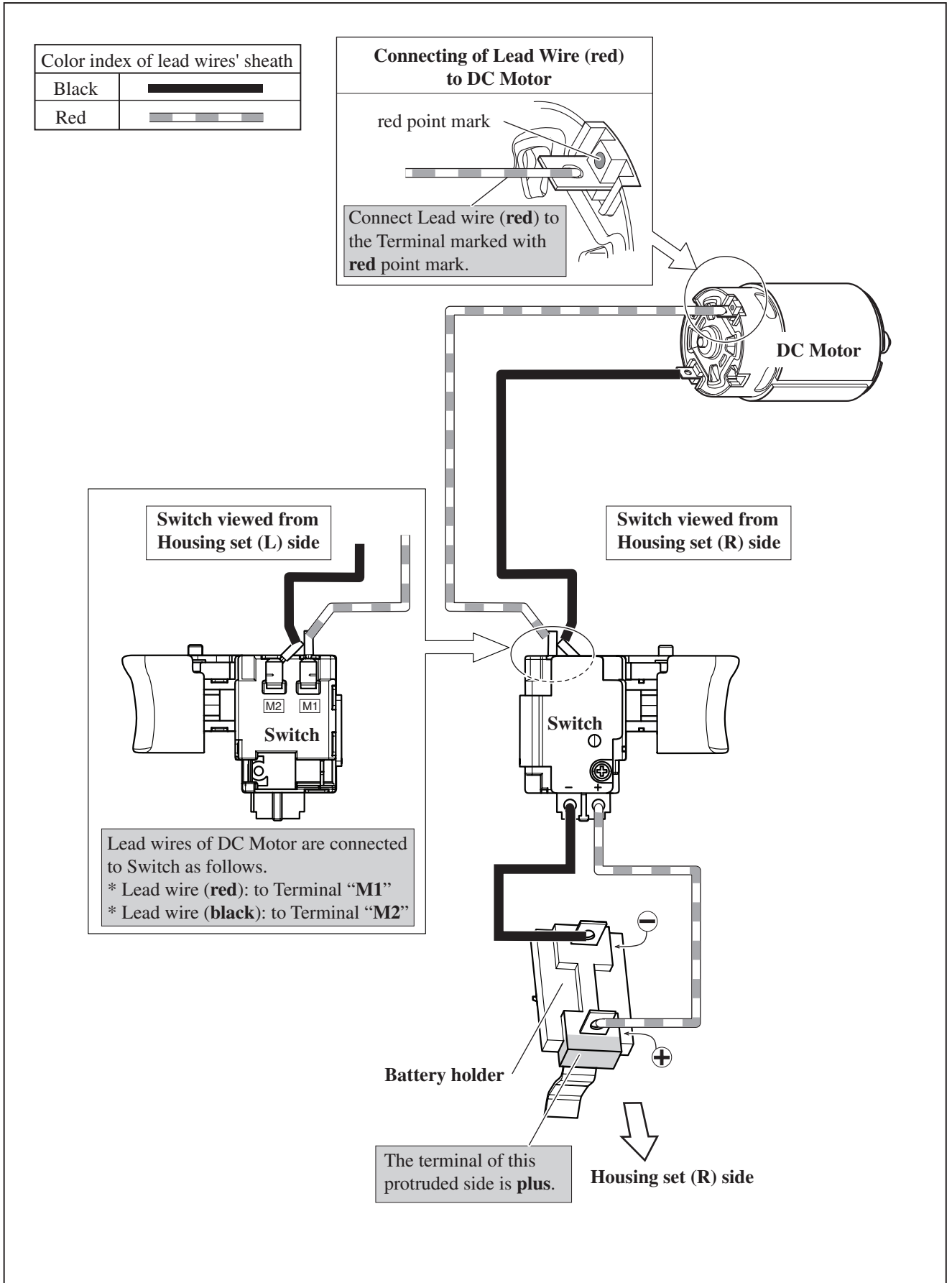

# ▶ Wiring diagram

Fig. D-2

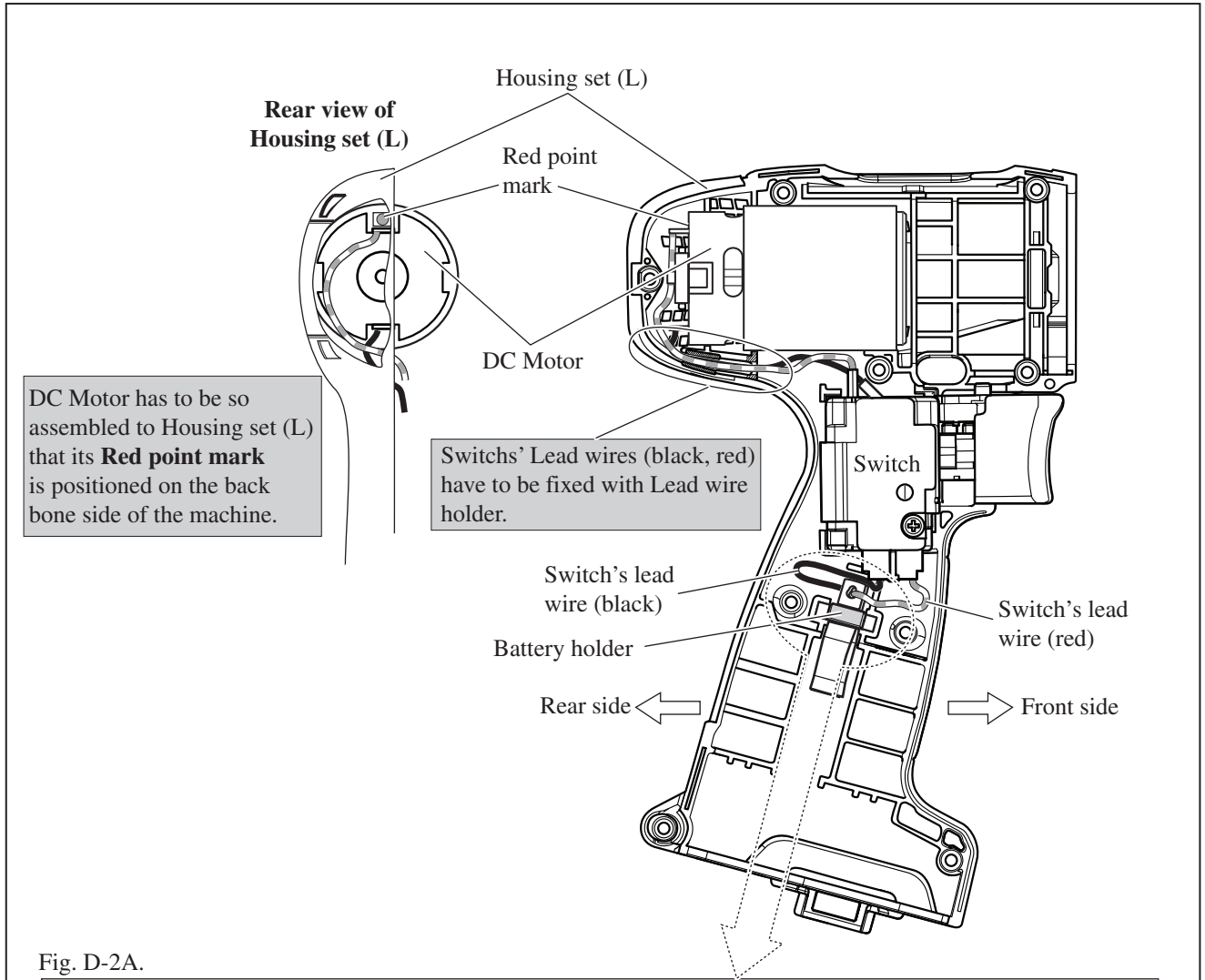

Fig. D-2A.

