

# T ECHNICAL INFORMATION



New Tool

**Models No.** ▶ 6310

**Description** ▶ 2-Speed 13mm Drill

## CONCEPTION AND MAIN APPLICATIONS

Designed to meet extra heavy duty job requirement for this class.

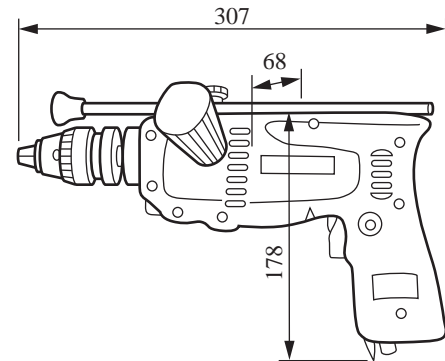

### ► Specifications

Voltage (V)	Current (A)	Cycle (Hz)	Continuous Rating (W)		Max. Output(W)
			Input	Output	
110	5.3	50-60	500		400
115	5.0	50-60	550		400
200	2.9	50-60	550		400
220	2.6	50-60	550		400
230	2.5	50-60	550		400
240	2.4	50-60	550		400

<b>NET WEIGHT</b>		2. Kgs.
<b>NO LOAD SPEED</b>		High
		Low
<b>CAPACITY</b>	Drill chuck capacity	2 -13 mm
	Drilling capacity	for steel
		for wood

### ► Standard equipment

- Chuck Key S-13 with a Holder
- Depth Rod assembly
- Grip (32)

The standard equipment for the tools shown may differ from country to country.