

T ECHNICAL INFORMATION



New Tool

Models No. ▶ 6311D

Description ▶ 13 mm (1/2") Cordless Diver Drill

CONCEPTION AND MAIN APPLICATIONS

More powerful version of the existing Model 6201 D/DW.
It is equipped with 13 mm (1/2") keyless chuck and 12 V battery.

Model 6311D is sold with a battery cartridge 1200 but without a fast charger.

Model 6311DW includes a battery cartridge 1200 and a fast charger DC 1200.

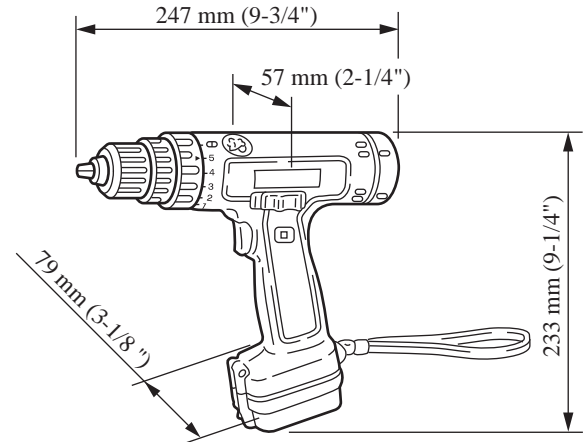

▶ Specifications

		DC Magnet Motor (12 V)
No Load Speed	High	0 - 1,150 R/min.
	Low	0 - 370 R/min.
Capacities	Steel	13 mm (1/2")
	Wood	24 mm (15/16")
	Wood Screws	6.4 mm (1/4") x 55 mm (2-3/16")
	Machine crews/Nuts	6 mm (1/4")
Max. Fastening Torque	At High Speed	About 65 kg.cm (4.7 ft.lbs)
	At Low Speed	About 210 kg.cm (15.2 ft.lbs)
Net Weight		1.95 kg (4.3 lbs)

▶ Standard equipment

Phillips Bit 2-65, Carrying Hook, Plastic Carrying Case (6311DW only)

▶ Optional accessories

Battery Cartridge 1200, Various size of Drill Bits, Various size of Slotted Bits, Various size of Phillips Bits, Foam Polishing Pad 125, Wool Bonnet 100 Rubber Pad Assembly, Fast Charger DC1200, Plastic Carrying Case

The standard equipment for the tools shown may differ from country to country.