

TECHNICAL INFORMATION



Product

Models No. ▶ 6333D

Description ▶ Cordless Driver Drills

CONCEPTION AND MAIN APPLICATIONS

Model	Battery	Fast Charger
6313DWAE	Battery 1222 X2	DC1411
6333DWA	Battery 1422 XI	DC1411
6333DWAE	Battery 1422 X2	DC1411

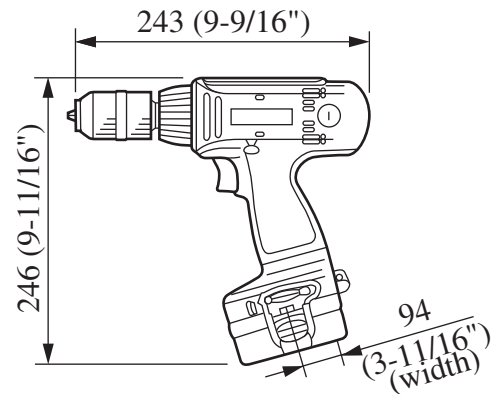
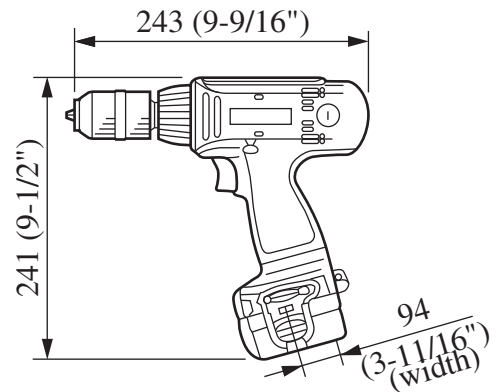

▶ Specifications

Motor	6313DA	DC 12V magnet motor
	6333DA	DC 14.4V magnet motor
Battery	6313DA	Battery 1222(Ni-Cd,12V,2.0Ah)
	6333DA	Battery 1422(NiCd,14.4V,2.0Ah)
No load speed	6313DA	H:0-1400rpm L:0-450rpm
	6333DA	H:0-1300rpm L:0-400rpm
Chuck capacity	2.0-13mm(1/16-1/2")	
Max.drilling capacities	Steel	13mm(1/2")
	Wood	25.4mm(1")
Setting off fastening torque	17 stages + drill-mode	
Max. fastening torque (drill-mode)	6313DA	L:Approx.254Kgf.cm(18.4ft.lbs)
	6333DA	L:Approx. 310Kgf.cm(22. 4ftlbs)
Declutching torque	6313DA	5-50Kgf..cm(0.4-3.6ft.lbs)
	6333DA	10-60Kgf.cm(0.7-4. 3ft.lbs)
Net weight (includingbattery)	6313DA	2.0Kg(4.4lbs)
	6333DA	2.1Kg(4.6lbs)

<Note>L : Low speed H : High speed

▶ Standard equipment

+ Bit 2-45 -----	2 pcs.	+ Bit 2-45 -----	2 pcs.
Battery Cover -----	2 pcs.	Battery Cover -----	2 pcs.
Plastic Carrying Case-----	1 pc.	Plastic Carrying Case -----	1 pc.

The standard equipment for the tools shown may differ form country to country

► **Optional accessories**

Drill Bit 1.5,2,3,4,5,6

Drill Bit for wood 9,12,15

Philips Bit 1-65,2-45,2-65,2-110,2-150,2-250,3-45,3-65,3-110

Slotted Bit 5-45,5-82,6-70,6.35-45,8-45,8-70

Socket Bit 7-55,8-55,10-55

Foam Polishing Pad 125

Rubber Pad Assembly

Wool Bonnet 100

Fast Charger DC1410

High Capacity Battery 1222 (for 6313DWAE)

High Capacity Battery 1422 (for 6333DWA,6333DWAE)