

T ECHNICAL INFORMATION



Models No. ▶ 6336D/6316D

Description ▶ Cordless Driver Drill

CONCEPTION AND MAIN APPLICATIONS

Model 6336D is the 14.4V version of existing Model 6343D 18V Cordless Driver Drills with applying Aluminum gear housing.
Model 6316D is the 12V version.

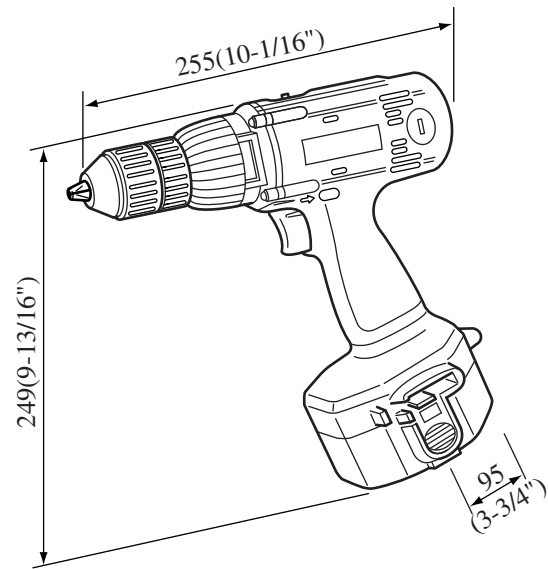

Model	Battery	Charger
6336DWA	Battery 1422	DC1411
6336DWAE	Battery 1422 x 2 pcs	
6336DWB	Battery 1433	
6336DWBE	Battery 1433x 2 pcs	
Model	Battery	Charger
6316DWA	Battery 1222	DC1411
6316DWAE	Battery 1222 x 2 pcs	
6316DWB	Battery 1233	
6316DWBE	Battery 1233x 2 pcs	

► Specifications

	6336DWBE	6316DWA
Motor	Direct current magnet motor	
Battery	Battery 1422 NiCad 14.4V, 2.0Ah	Battery 1222 NiCad 12V, 2.0Ah
	Battery 1433 NiMH 14.4V, 2.2Ah	Battery 1233 NiMH 12V, 2.2Ah
Speed at no load	High speed 0~1300 R/min	
	Low speed 0~400 R/min	
Chuck capacity	1.5(1/16") - 13(1/2")	
Drilling capacity	Iron works 13mm(1/2")	
	Wood works 36mm(1-7/16")	Wood works 30mm(1-3/16")
Torque adjusting	16 levels + Direct connection	
Max. tighten torque	48 N.m(390 kgf-cm,28ft•lbs)	32 N.m(330 kgf-cm,24ft•lbs)
Clutch operative torque	1 N.m(10kgf-cm,0.7ft•lbs) - 6 N.m(60kgf-cm,4.3ft•lbs)	

► Standard equipment

Battery cover ----- 1pc (DWAE/DWBE: 2pcs)
+ - Bit 2-45 ----- 2pcs
Set Plate

► Optional accessories

Drill 1.5,2,3,4,5,6
Drill Bit for wood 9,12,15
+ Bit 1-65,2-45,2-65,2-110,2-150,2-250,3-45,3-65,3-110
- Bit 5-45,5-82,6-70,6.35-45,8-45,8-70
Socket bit 7-55,8-55,10-55
Buff 125
Rubber pad assembly
Wool bonnet100
Grip Assemble, Stopper pole assemble
Charger DC1411,DC1801
Battery (NiCad 1422)
Battery (NiMH 1433)

The standard equipment for the tools shown may differ from country to country

► Repair

(1) Notes in Disassembly

- When exchanging Gear assembly, remove Drill chuck in advance.
(If you only dismantle Housing, removal of Chuck is unnecessary.)
- When detaching Chuck, hold two-face width of Spindle.
- In disassembly, be careful not to lose Compression spring 4 in Speed change lever, because it easily goes away.

(2) Note in Assembly

1 Assembly of Motor and Gear assembly

- * Since Motor bracket is equipped in Gear assembly for repair, detach Motor bracket from Gear assembly. Be careful that the content may not go out from Gear assembly at that time.

1) Screw Motor bracket to Motor.

2) Attach the above 1) Motor with Bracket to Gear assembly.

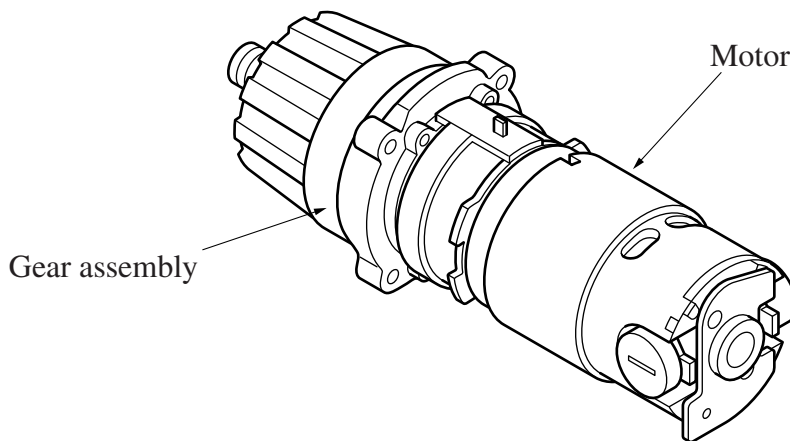

Figure 2

2 Installing of Speed change lever

- 1) Place two Compression spring 4s into Speed change lever.
- 2) Being careful that Compression spring 4 may not comes out , install Speed change lever assembly in the projection of Change lever as shown in Figure 3.

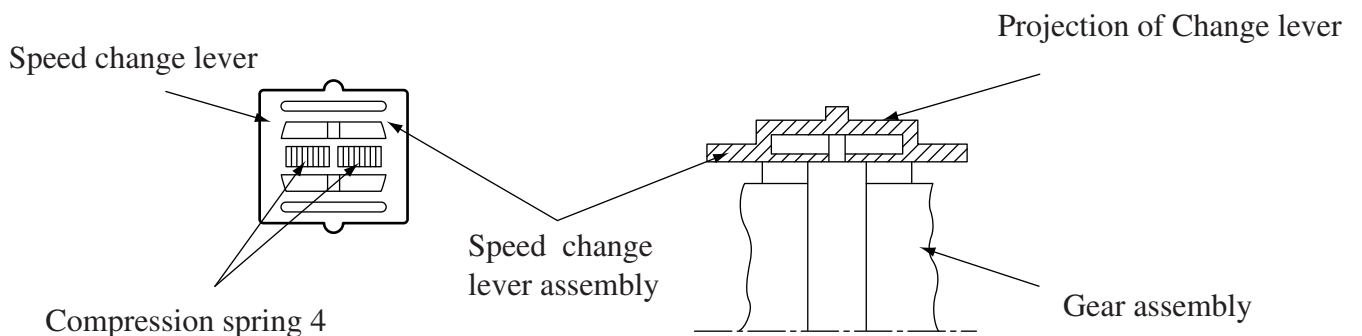

Figure 3

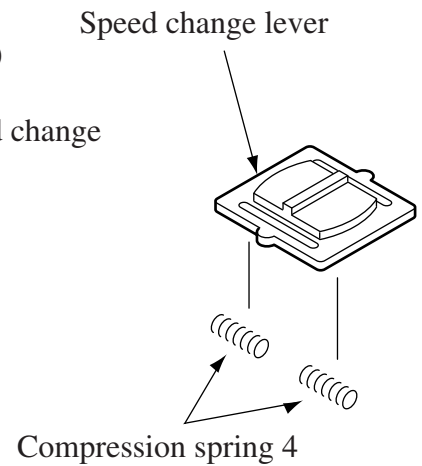

Figure 1

3 Attaching to Housing

- 1) When attaching a unit of Gear assembly and Motor, etc. to Housing L, place Speed change lever in the position as shown in Figure 4.

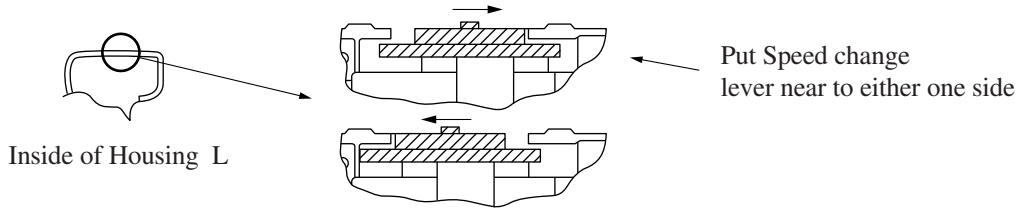
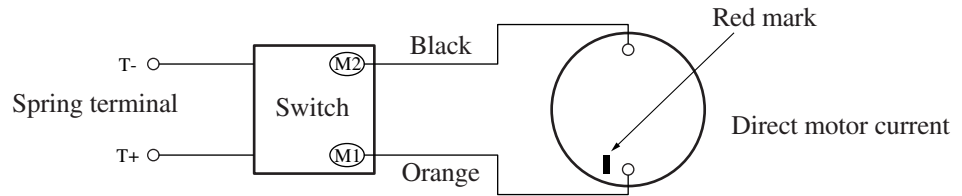

Figure 4

4 Assembly of chuck

- 1) In assembly of Chuck, hold the two-face width and tighten by 50~60 N.m (500~600kgf.cm).
 - If tightened by the torque less than the above, Chuck may loosen in reverse rotation, which will break Screw for Chuck and Chuck may comes off.
 - Do not tighten Chuck by low speed lock torque, because you may be swung around and dangerously.
- 2) Used screw for fixing Chuck is left-handed.

► Wiring diagram



► Details of wiring

Inside of Housing L

