

T ECHNICAL INFORMATION



PRODUCT

P 1 / 5

Models No. ▶ 6319D/ 6339D/ 6349D

Description ▶ Cordless Driver Drills 12V/ 14.4V/ 18V

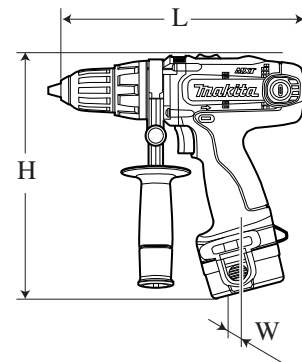

CONCEPT AND MAIN APPLICATIONS

The above products have been developed as successor models of the current 6343D series models and as the highest grade series models among Makita Cordless Driver Drills.

Their brief advantages are;

*Powerful motor provides high operation efficiency.

*Mechanical 3-speed;

3rd speed: higher than the predecessors for finishing light duty jobs with extremely high efficiency

1st speed: lower than the predecessors for extra-heavy duty applications

*Easy operation mode change

*All the great advantages as Model 6343D series models

Dimensions: mm (")			
Model No.	6319D	6339D	6349D
Length (L)	246 (9-11/16)		
Width (W)	94 (3-11/16)	94 (3-11/16)	95 (3-3/4)
Height (H)	243 (9-9/16)	247 (9-3/4)	252 (9-7/8)

These new products are available in the following variations:

6319D

Model No.	Battery		Battery cover (quantity)	Charger	Flash light
	type	Quantity			
6319DWAE	1222 (Ni-Cd 2.0Ah)	2	2	DC1414	w/o light
6319DWAE3	1222 (Ni-Cd 2.0Ah)	3	3		ML120
6319DWALE	1222 (Ni-Cd 2.0Ah)	2	2		w/o light
6319DWDE	1234 (Ni-MH 2.6Ah)	2	2		ML120
6319DWDE3	1234 (Ni-MH 2.6Ah)	3	3		w/o light
6319DWDLE	1234 (Ni-MH 2.6Ah)	2	2		ML120
6319DWFE	1235 (Ni-MH 3.0Ah)	2	2		w/o light
6319DWFE3	1235 (Ni-MH 3.0Ah)	3	3		

6339D

Model No.	Battery		Battery cover (quantity)	Charger	Flash light
	type	Quantity			
6339DWAE	1422 (Ni-Cd 2.0Ah)	2	2	DC1414	w/o light
6339DWAE3	1422 (Ni-Cd 2.0Ah)	3	3		ML140
6339DWALE	1422 (Ni-Cd 2.0Ah)	2	2		w/o light
6339DWDE	1434 (Ni-MH 2.6Ah)	2	2		ML140
6339DWDE3	1434 (Ni-MH 2.6Ah)	3	3		w/o light
6339DWDLE	1434 (Ni-MH 2.6Ah)	2	2		ML140
6339DWFE	1435 (Ni-MH 3.0Ah)	2	2		w/o light
6339DWFE3	1435 (Ni-MH 3.0Ah)	3	3		

6349D

Model No.	Battery		Battery cover (quantity)	Charger	Flash light
	type	Quantity			
6349DWAE	1822 (Ni-Cd 2.0Ah)	2	2	DC1804	w/o light
6349DWAE3	1822 (Ni-Cd 2.0Ah)	3	3		ML180
6349DWALE	1822 (Ni-Cd 2.0Ah)	2	2		w/o light
6349DWDE	1834 (Ni-MH 2.6Ah)	2	2		ML180
6349DWDE3	1834 (Ni-MH 2.6Ah)	3	3		w/o light
6349DWDLE	1834 (Ni-MH 2.6Ah)	2	2		ML180
6349DWFE	1835 (Ni-MH 3.0Ah)	2	2		w/o light
6349DWFE3	1835 (Ni-MH 3.0Ah)	3	3		

► Specification

Model No.		6319D	6339D	6349D
Battery	Voltage: V	12V	14.4V	18V
	Capacity: Ah/ Cell	2.0/ Ni-Cd	2.0/ Ni-Cd	2.0/ Ni-Cd
		2.6/ Ni-MH	2.6/ Ni-MH	2.6/ Ni-MH
3.0/ Ni-MH		3.0/ Ni-MH	3.0/ Ni-MH	
Max. out put: W		210	250	310
No load speed: min.-1=rpm	3rd (Heighest)	0 - 1,600	0 - 1,700	
	2nd (High)	0 - 550	0 - 600	
	1st (Low)	0 - 300	0 - 300	
Fastening torque: N.m (ft.lbs)	Hard joint	65 (47.9)	70 (51.6)	80 (59.0)
	Soft joint	31 (22.8)	32 (23.6)	40 (25.7)
Drill chuck	Capacity: mm (")	1.5 -13 (1/16 - 1/2)		
	Type	Keyless, Single sleeve		
Drilling capacity: mm (")	Steel	13 (1/2)	13 (1/2)	13 (1/2)
	Wood	45 (1-3/4)	50 (2)	65 (2-9/16)
Electric brake		Yes		
Torque adjustment		Yes		
Variable speed control		Yes		
Reverse switch		Yes		
Net weight: kg (lbs) [includes battery]		2.2 (4.9)	2.3 (5.1)	2.6 (5.7)

► Standard equipment

(for all variations listed in page 1)

Philips bit 2-45 2

Grip assembly 1

Battery cover For quantity, see the variation list in page 1.

Note: The standard equipment for the tool shown above may differ from country to country.

► Optional accessories

For all models

*Assorted drill bits for
wood and steel

*Assorted driver bits

For 6319D

Battery 1220

Battery 1222

Battery 1234

Battery 1235

Battery 1235A

Battery 1235F

Charger DC1414

Charger DC1439

Charger DC1804

Automotive Charger DC1422

Automotive Charger DC1822

For 6339D

Battery 1420

Battery 1422

Battery 1434

Battery 1435

Battery 1435F

Charger DC1414

Charger DC1439

Charger DC1804

Automotive Charger DC1422

Automotive Charger DC1822

For 6349D

Battery 1822

Battery 1834

Battery 1835

Battery 1835F

Charger DC1804

Automotive Charger DC1822

► Repair

[1] DISASSEMBLY/ ASSEMBLY

[1] -1. Drill Chuck

REMOVAL

When replacing Gear assembly, remove Drill chuck first as described below.
(When replacing only Housing, you need not remove Drill chuck.)

- 1) After opening the chuck jaws to the full, remove the chuck screw (M6x22 (-) Flat head screw) by turning it clockwise.
Use impact driver drill if it is difficult to remove the screw.
- 2) Slide Speed change lever to the position of "1" (1st speed), and slide Action mode change lever to the drill mode as illustrated in **Fig. 1**.
Secure the short arm of a hex wrench with the chuck jaws. Hold the machine firmly, and then remove Drill chuck by hitting the long arm of the hex wrench using plastic hammer to turn Drill chuck counterclockwise. (**Fig. 2**)

Fig. 1

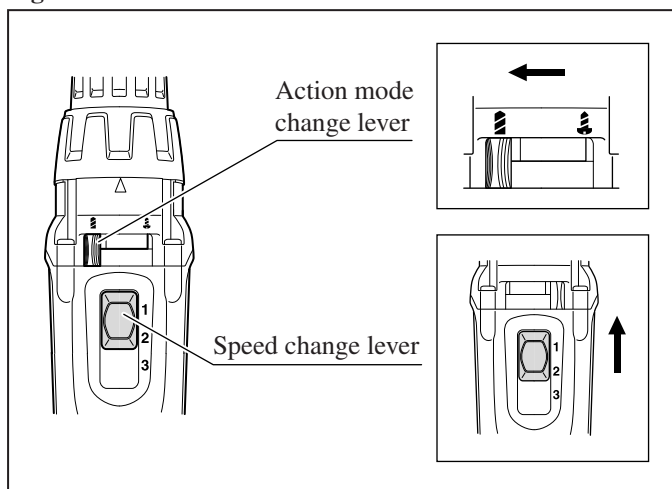
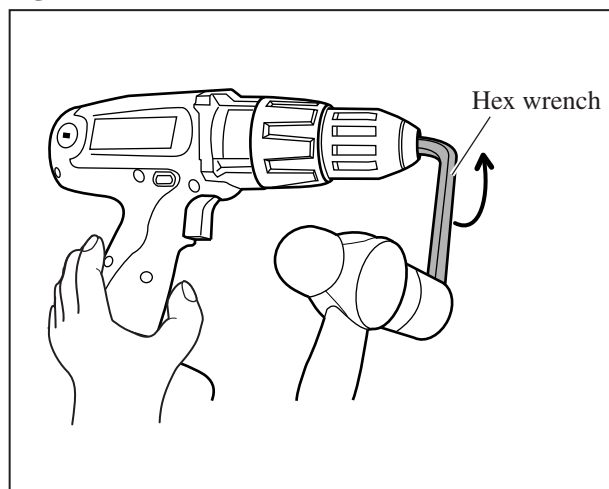

Fig. 2



Note:

This product has "Spindle Lock system".
After hex wrench is secured in Drill chuck, it is impossible to turn the wrench in order to adjust the position of its long arm. (**Fig. 3**)
Therefore, make sure that the hex wrench is positioned as illustrated in **Fig. 2** before securing it in drill chuck.

Fig. 3

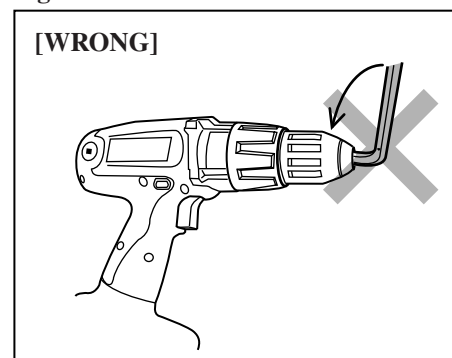

Caution:

Place the tool on a work table so that Drill chuck touches the surface of the work table as illustrated to left in **Fig. 4**.
Failure to follow this instruction can result in deformation of Spindle.

Fig. 4

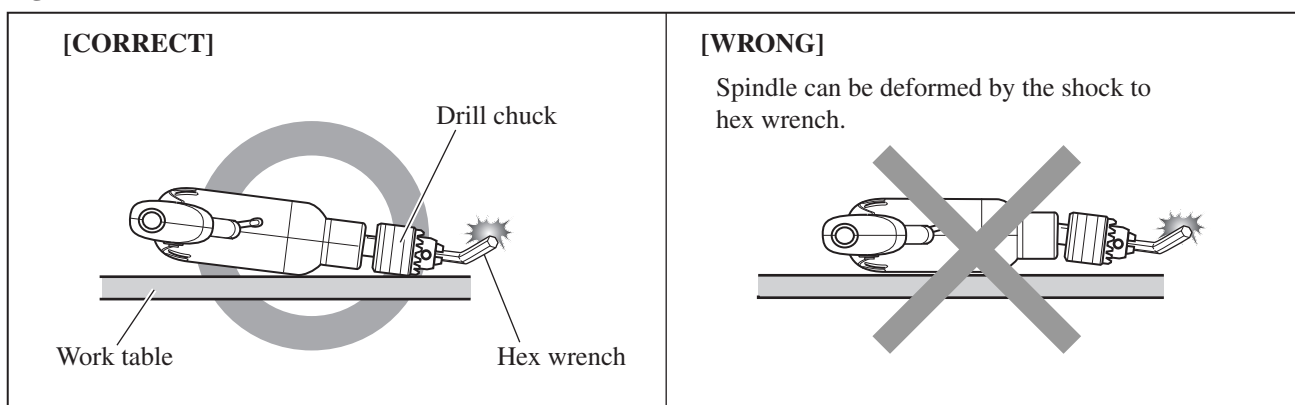

► Repair

[1] -1. Drill Chuck (cont.)

INSTALLATION

- 1) Make sure that Flat washer 13 is mounted to Spindle before installing Drill chuck. (**Fig. 5**)
- 2) Slide Speed change lever to the position of "1" (1st speed), and slide Action mode change lever to the drill mode as illustrated in **Fig. 1**. Push in F/R change lever for the forward rotation mode. (**Fig. 6**)
Secure the short arm of a hex wrench in the chuck jaws, and the long arm in vise. Hold the grip of the machine firmly so that your hand cannot be pulled away by reaction torque. And then tighten Spindle into Drill chuck by pulling the trigger of Switch until Spindle is locked. (**Fig. 6**)

Note: Release the trigger of Switch just after Spindle is locked. Do not keep on pulling the trigger for longer than one second.

- 3) Fasten Drill chuck to Spindle with the chuck screw (M6x22 (-) Flat head screw) by turning it counterclockwise.
If you reuse a screw removed from Drill chuck, apply an appropriate amount of adhesive (ThreeBond 1321B/ 1342 or Loctite 242) to the screw for secure fastening.

Fig. 5

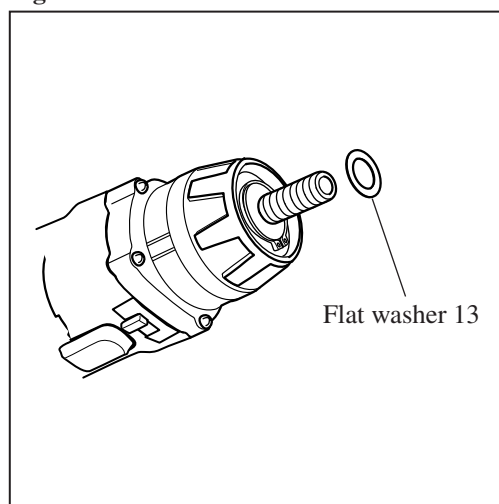
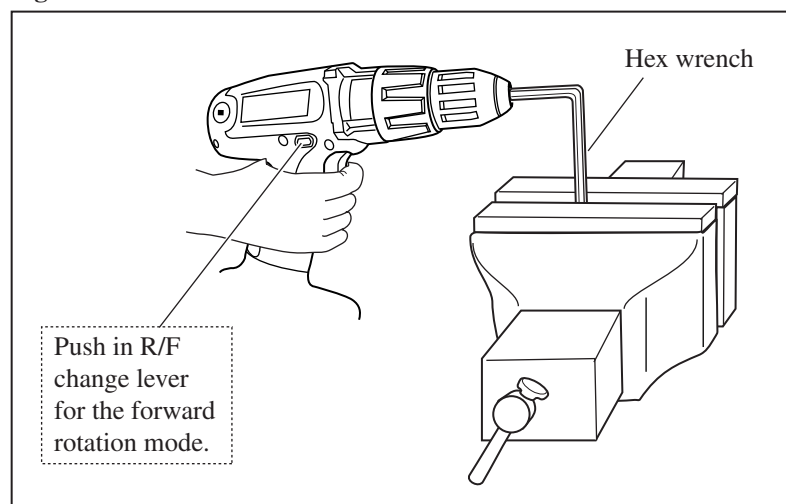

Fig. 6



[1] -2. Installing Speed Change Lever

- 1) Before installing Speed change lever on Gear assembly, make sure that;
 - a. Two Leaf springs are installed to Speed change lever as illustrated to left in **Fig. 7**.
 - b. Two compression springs are installed to speed change lever as illustrated to right in **Fig. 7**.
- 2) Assemble Speed change lever to the projection on Gear assembly. (**Fig. 8**)

Fig. 7

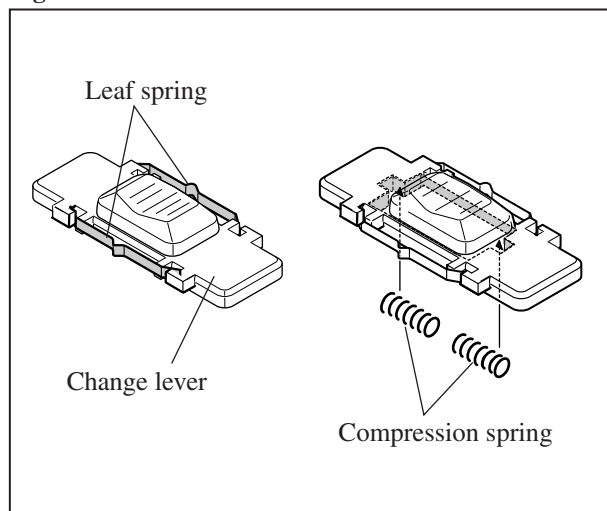
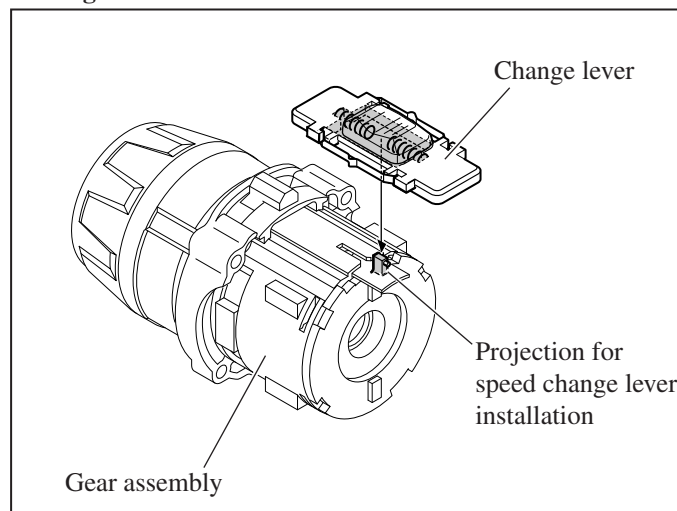

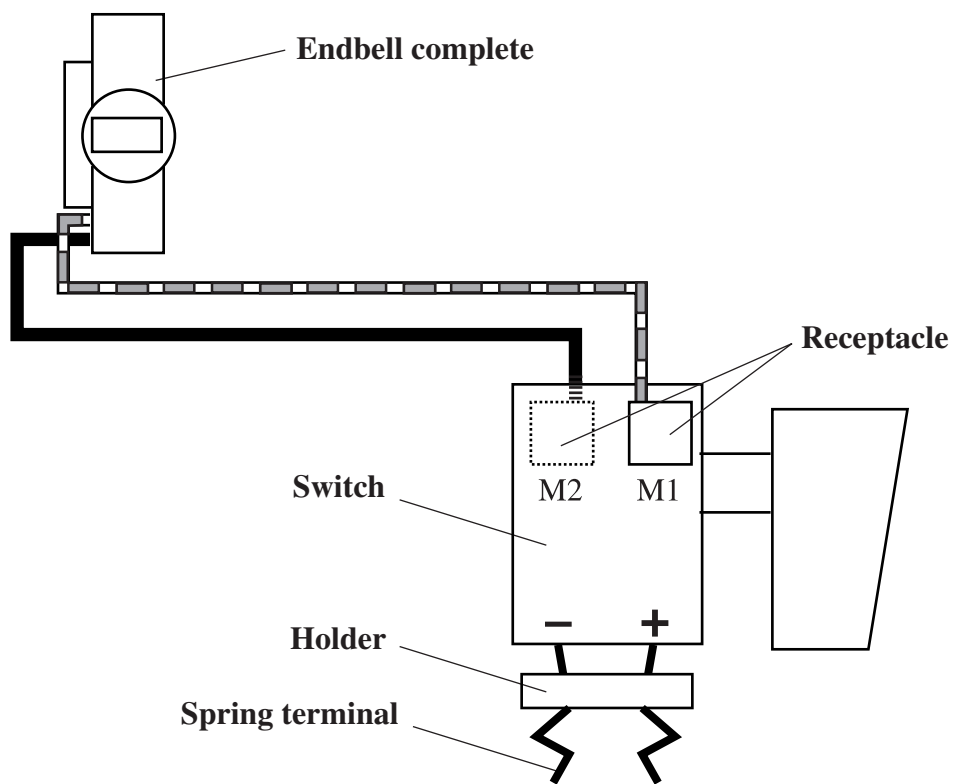

Fig. 8



► **Circuit diagram**

Color index of lead wires' sheath	
Black	
Red	



► **Wiring diagram**

