

T ECHNICAL INFORMATION



New Tool

Models No. ▶ 6402

Description ▶ MAKITA 10 mm Drill

CONCEPTION AND MAIN APPLICATIONS

This machine is the more high-graded model of the 6510LVR.

By holding the motor in some between this model and the 6820V, the power has been upgraded. For the drill chuck, the outer diameter has been enlarged than that of 6510LVR to increase the gripping force and to make the high grade feeling.

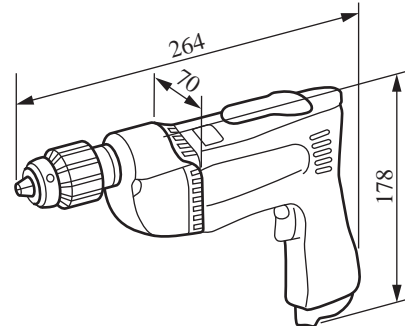

► Specifications

Voltage(V)	Current(A)	Frequency(Hz)	Consumed power(W)	Rated output(W)	Max. output(W)
100	6.0	50-60	570	280	460
115	5.2	50-60	570	280	460
200	3.0	50-60	570	280	460
220	2.7	50-60	570	280	460
230	2.6	50-60	570	280	460
240	2.5	50-60	570	280	460

No load speed(R.P.M.)	0-1,200rpm	
Chuck capacity(mm)	0.6-10mm	
Capacity(mm)	for steel	10mm
	for wood	21mm
Net weight(kg)	1.7kg	
Cord length(m)	2.5m	

► Standard equipment

Chuck key 10

The standard equipment for the tools shown may differ form country to country.

► Circuit drawing

a. Domestic & general specifications

* The terminal board is used for export to America.

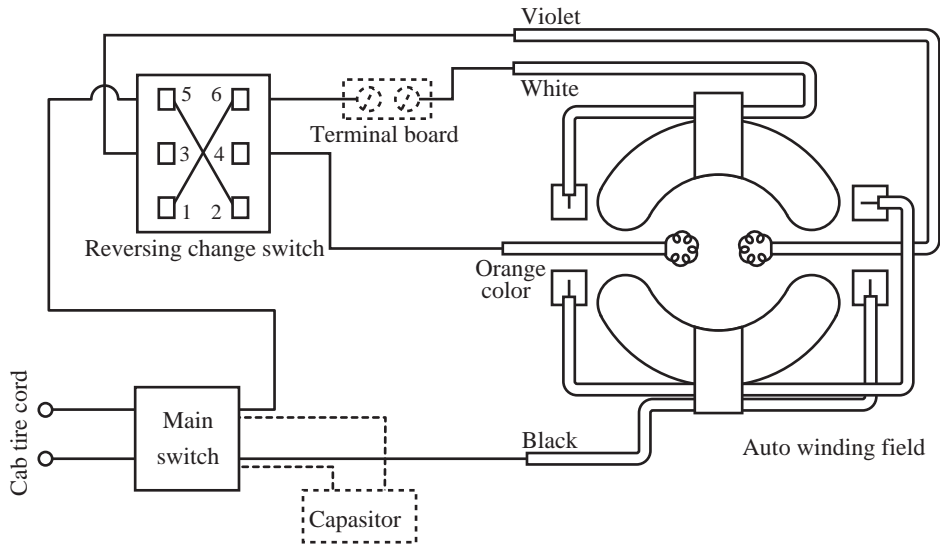

b. For the countries where the interference protection is required (for West Germany, Austria, France, Holland, England etc.)

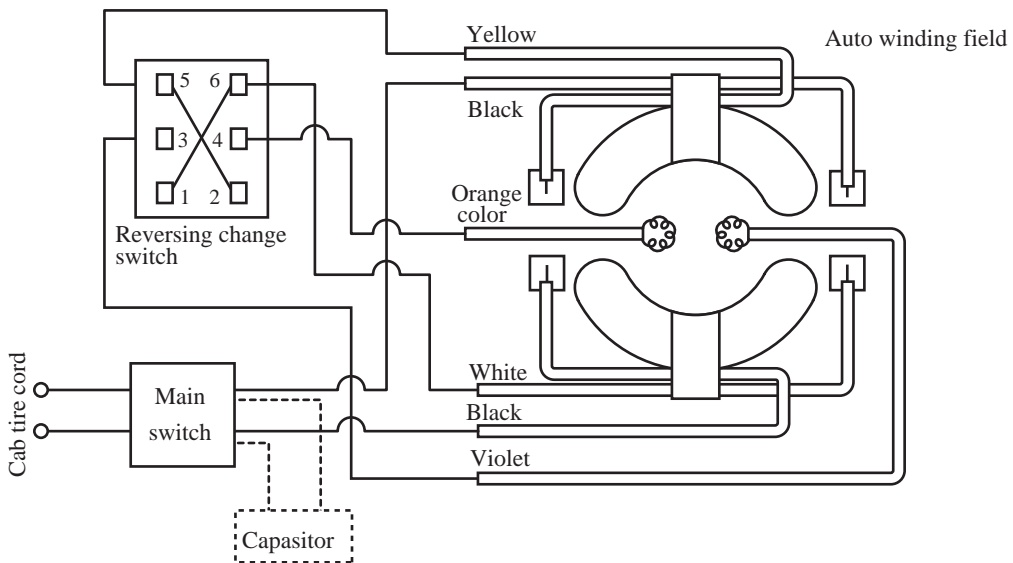

<Cautions>

1. Connect the reversing change switch as shown on the right figure. Although the terminal numbers are not displayed, they are specified as shown on the figure for the convenience.

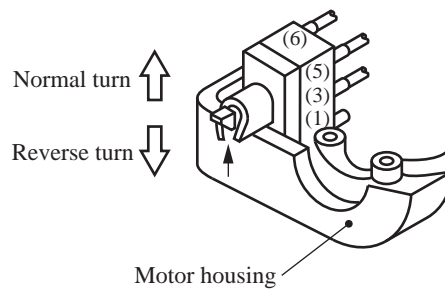

2. Depending on the destinations, the condenser is not used or the three legs are used in some areas.