

# T ECHNICAL INFORMATION



New Tool

Models No. ▶ 6407,6408  
Description ▶ 10mm Drills

6407

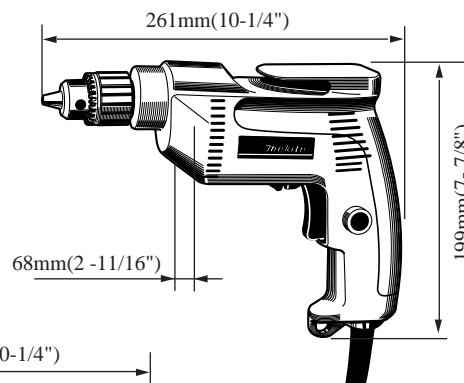

## C ONCEPT AND MAIN APPLICATIONS

Model 6407/6408 are upgraded versions of the existing Model 6405/6406.

Their brief benefits are;

More powerful

than Model DW100/DW106(Dewalt)

Easy operation

by ergonomic design for easily pushing

the axis of drilling

Model 6407 is with a conventional(keyed) drill chuck.

Model 6408 is with a keyless drill chuck.

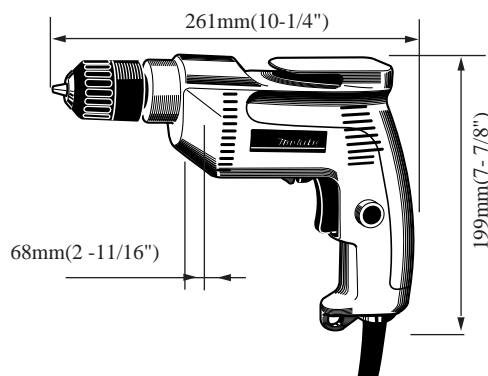

6408

### ► Specifications

Voltage (V)	Current (A)	Cycle (Hz)	Continuous Rating (W)		Max. Output(W)
			Input	Output	
100	5.6	50/60	530	280	480
120	4.9	50/60	530	280	480
220	2.5	50/60	530	280	480
230	2.4	50/60	530	280	480
240	2.3	50/60	530	280	480

No load speed		0-2500rpm
Drill chuck capacity		1.5-10mm(1/16-3.8")
Max.drilling capacities	Steel	10mm(3/8")
	Wood	25mm(1")
Net weight		1.4Kg(3.1lbs)
Cord length		2.5m(8.2ft)

### ► Standard equipment

Chuck Key S10 (Model 6407 only)

### ► Optional accessories

Drill bit 1.5,2,3,4,5,6

Drill bit for wood 9,12,15

The standard equipment for the tools shown may differ from country to country.