

TECHNICAL INFORMATION



PRODUCT

P 1 / 12

Model No. ▶ 6411, 6412, 6413, M611

Description ▶ Drill 10mm (3/8")

CONCEPT AND MAIN APPLICATIONS

Models 6411, 6412, 6413 and M611 are cost-competitive 10mm Drills developed as the successor models of 6409, 6410, 6510SB and M610, featuring compact and lightweight design yet with high durability.

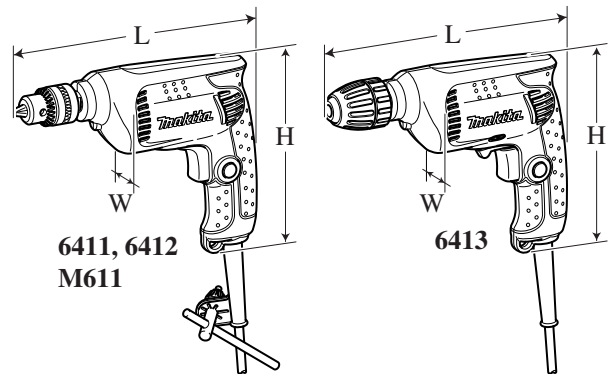

Listed below are the specification differences among the four models.

Model No.	6411	6412	6413	M611
Reverse switch	No	Yes	Yes	Yes
Variable speed control by trigger	No	Yes	Yes	Yes
Drill chuck type	Keyed	Keyed	Keyless	Keyed

Dimensions: mm (")		
Model	6411, 6412 M611	6413
Length (L)	228 (9)	234 (9-1/4)
Width (W)	64 (2-1/2)	
Height (H)	183 (7-1/4)	

► Specification

Voltage (V)	Current (A)	Cycle (Hz)	Continuous Rating (W)		Max. Output (W)
			Input	Output	
110	4.3	50/ 60	450	230	350
120	4.0	50/ 60	---	230	350
220	2.2	50/ 60	450	230	350
230	2.1	50/ 60	450	230	350
240	2.0	50/ 60	450	230	350

Capacities: mm (")	Steel	10 (3/8)
	Wood	25 (1)
No load speed: min-1=rpm		6411: 3,000 6412, 6413, M611: 0 -3,000
Chuck capacity: mm (")		1.5 - 10 (1/16 -3/8)
Double insulation		Yes
Power supply cord: m (ft)		2.0 (6.6)
Net weight: kg (lbs)		1.2 (2.6)

► Standard equipment

Chuck key S10 1 (for **6411, 6412, M611**)

Key holder 10 1 (for **6411, 6412, M611**)

Note: The standard equipment for the tool shown above may differ by country.

► Optional accessories

Drills bits

► **Repair**

CAUTION: Unplug the machine for safety before repair/ maintenance in accordance with the instruction manual!

[1] NECESSARY REPAIRING TOOLS

Code No.	Description	Use for
1R004	Retaining ring pliers ST-2	Removing/Installing Ring spring 13 from Spindle
1R139	Drill chuck extractor	Locking Spindle when removing Drill chuck from Spindle
1R220	Ratchet head 9.5	Assembling Drill chuck to Spindle Note: Preset the fastening torque of 1R223 to 25- 30 N.m (250- 300kgf.cm).
1R222	Socket adapter	
1R223	Torque wrench shaft 20- 90N.m	
A-33750	Bit Adaptor	
1R231	1/4" Hex. shank bit for M8	
1R269	Bearing extractor	Removing Ball bearing 606ZZ
1R273	Ring spring 26 setting tool B	Removing/Installing Helical gear 35
1R031	Bearing setting pipe 28-20.2	Removing/Installing Ball bearing 6902ZZ

[2] LUBRICATION

Apply Makita grease N. No.1 to the following portions designated with the black triangle to protect parts and product from unusual abrasion.

Item No.	Description	Portion to lubricate
⑦	Housing	Gear room for Helical Gear 35 (Apply approx. 3g.)

Fig. 1

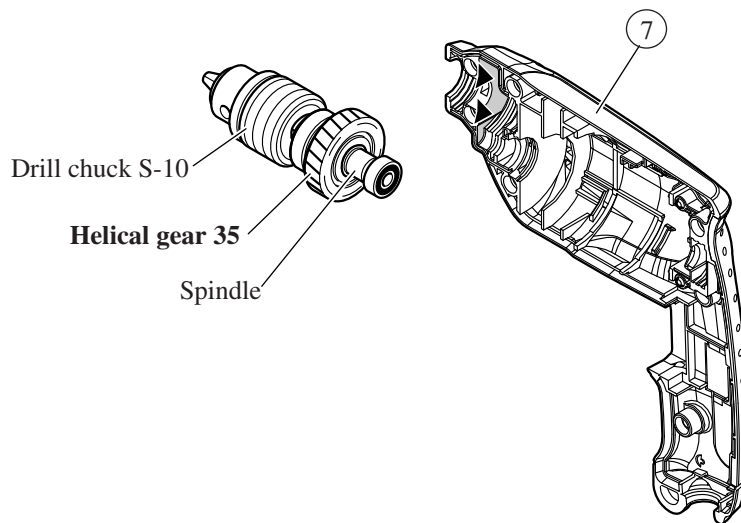

► Repair

[3] DISASSEMBLY/ASSEMBLY

[3] -1. Drill Chuck

DISASSEMBLING

See **Fig. 2**.

- 1) Fix 1R139 securely in vise, then lock Spindle by putting it in the U-shaped notch of 1R139.
- 2) Fix Hex wrench 10 securely in Drill chuck. Attach an appropriate steel pipe to Hex wrench 10 as extension bar.
- 3) Remove Drill chuck from Spindle by turning Drill chuck counterclockwise using Hex wrench 10 and steel pipe.

Fig. 2

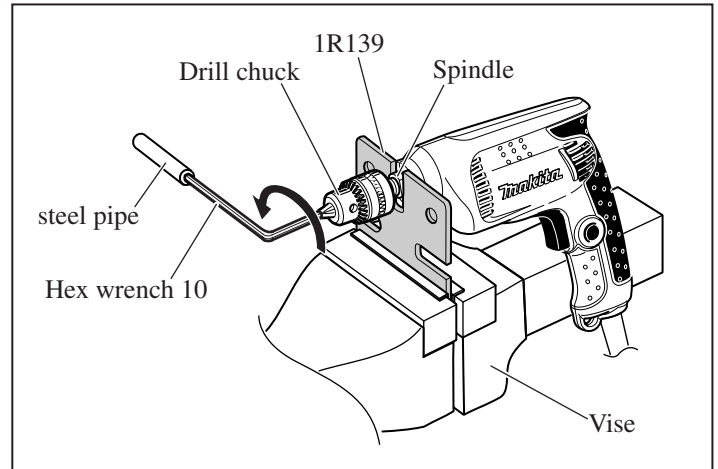

ASSEMBLING

- 1) Assemble 1R220, 1R222, 1R223 and A-33750 as illustrated in **Fig. 3**.
Note: Preset the fastening torque of 1R223 to 25- 30N.m (250- 300 kgf.cm).
- 2) Lock Spindle as you did in step 1) of DISASSEMBLING, then fix 1R231 securely in Drill chuck. (**Fig. 4**)
- 3) Assemble Drill chuck to Spindle by turning 1R231 and Drill chuck clockwise using the repairing tools described in step 1) of ASSEMBLING. (**Fig. 4**)

Fig. 3

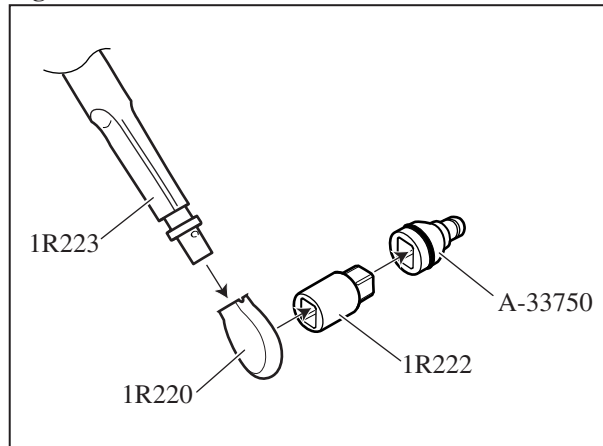
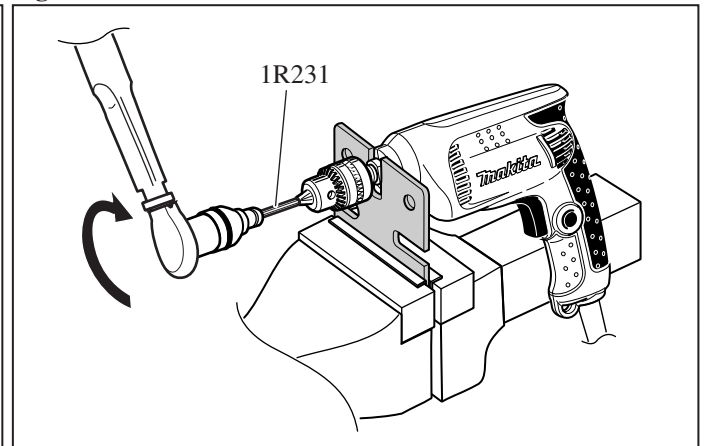

Fig. 4



► **Repair**

[3] DISASSEMBLY/ASSEMBLY

[3] -2. Gear Section

DISASSEMBLING

- 1) After disassembling Drill chuck as illustrated in **Fig. 2**, separate Housing (R) from Housing (L).
Remove Gear section from Housing (L). (**Fig. 5**)
- 2) Disassemble Gear section as illustrated in **Figs. 6, 7, 8**.

Fig. 5

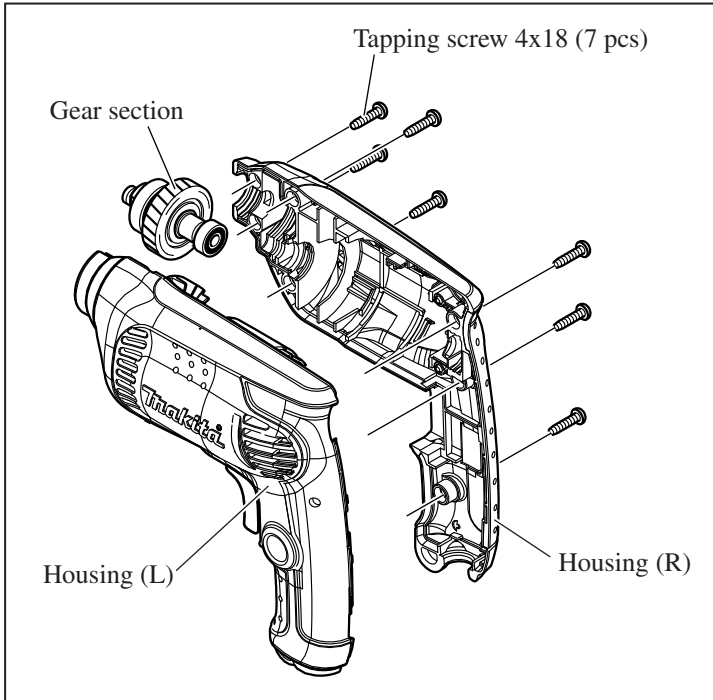

Fig. 6

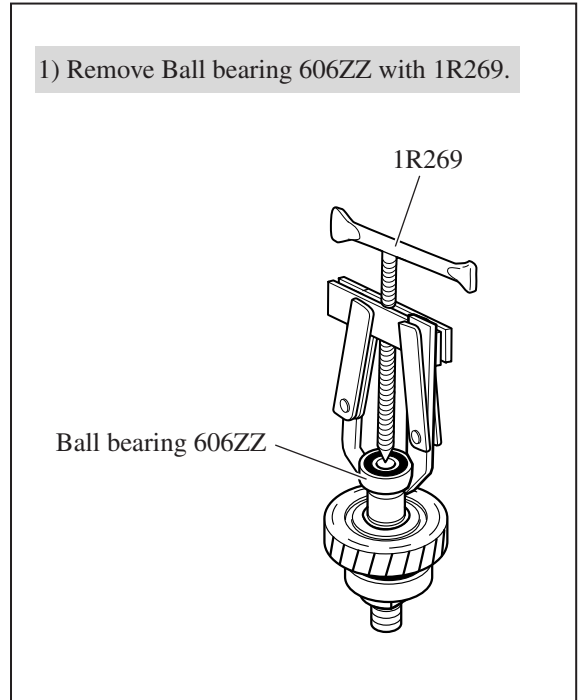

Fig. 7

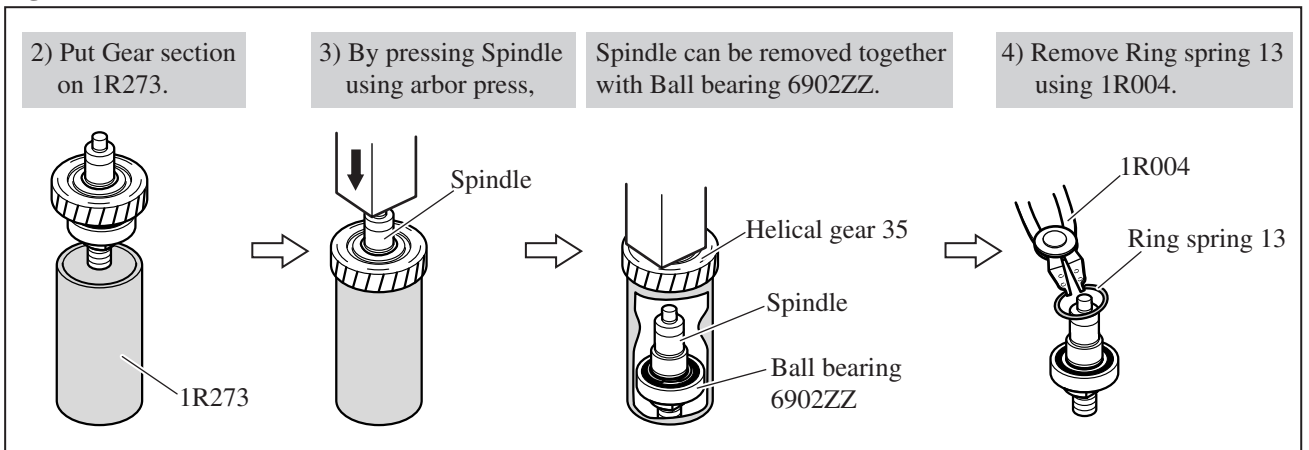
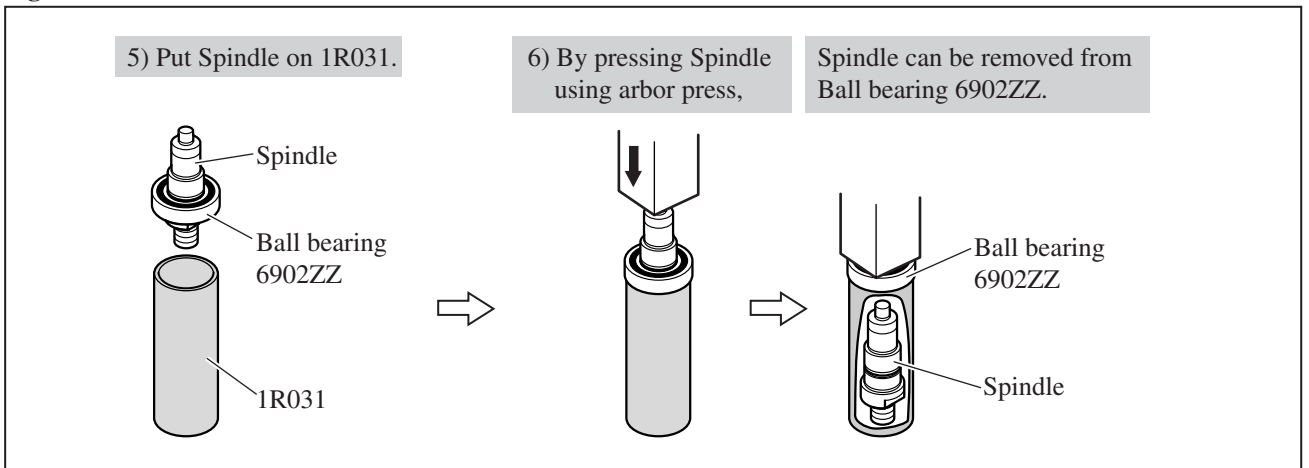

Fig. 8



► **Repair**

[3] DISASSEMBLY/ASSEMBLY

[3] -2. Gear Section (cont.)

ASSEMBLING

- 1) Assemble Gear section as illustrated in **Fig. 9** to **Fig. 12**.
- 2) Assemble Gear section to Housing (L). (**Fig. 5** in page 4)

Fig. 9

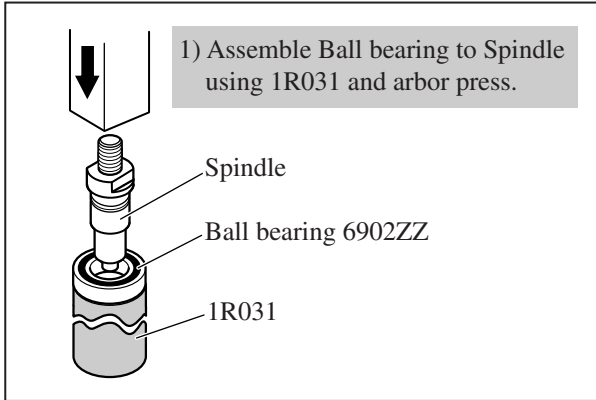

Fig. 10

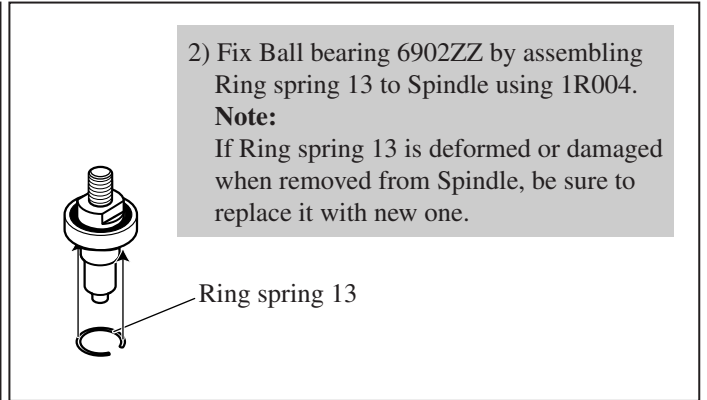

Fig. 11

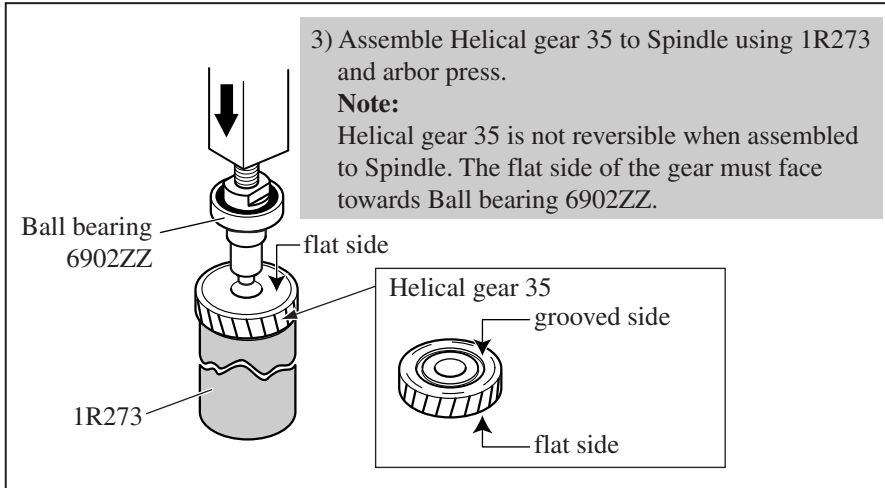
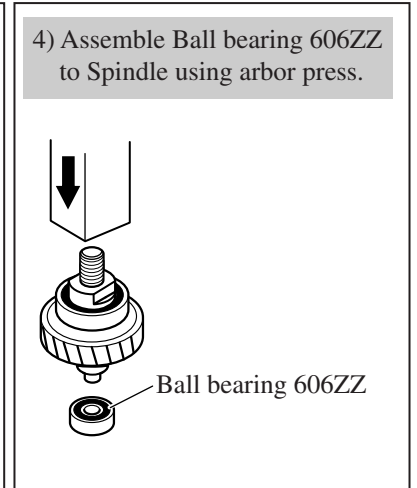

Fig. 12



[3] -3. Motor Section

DISASSEMBLING

- 1) After separating Housing (R) from Housing (L), disconnect Carbon brushes from Armature commutator by pulling off Brush holders from Housing (L). Disassemble Motor section from Housing (L). (**Fig. 13**)
- 2) Pull out Armature from Field. (**Fig. 14**)

Fig. 13

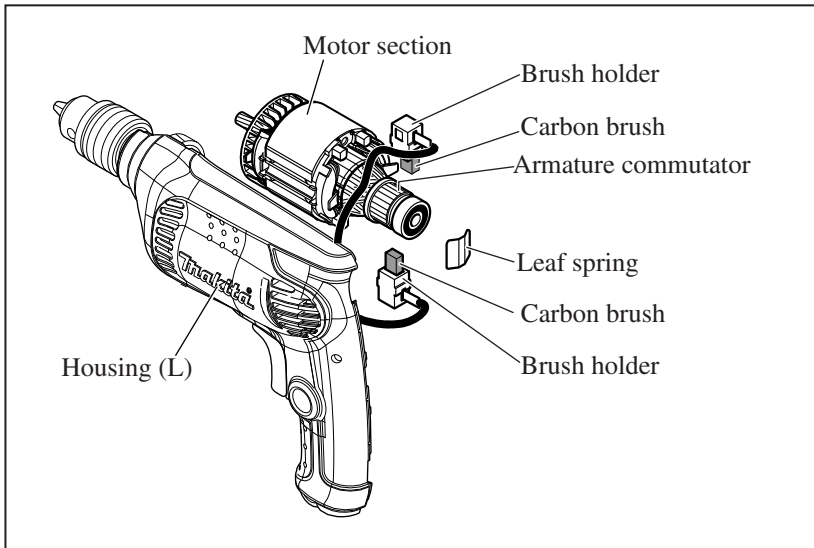
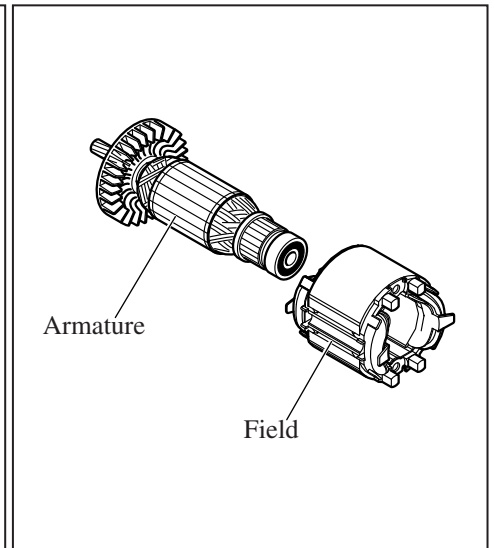

Fig. 14



► Repair

[3] DISASSEMBLY/ASSEMBLY

[3] -3. Motor Section (cont.)

ASSEMBLING

Do the reverse of the disassembling steps.

Note:

Leaf spring is not reversible when assembled to Housing (L). The concave side must face towards Ball bearing 627ZZ on Armature. (**Fig. 15**)

Fig. 15

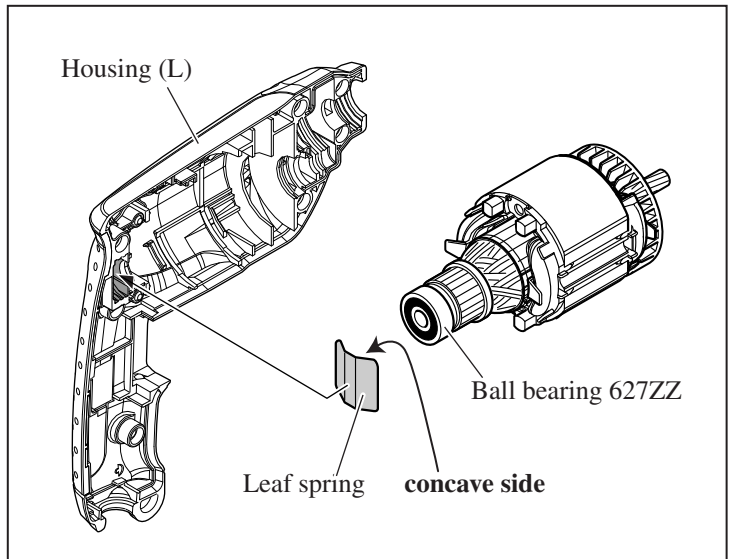

► **Circuit diagram**

Model 6411 (without Variable speed control and Reverse switch)
Machines Without Choke Coil and Noise Suppressor

Fig. D-1

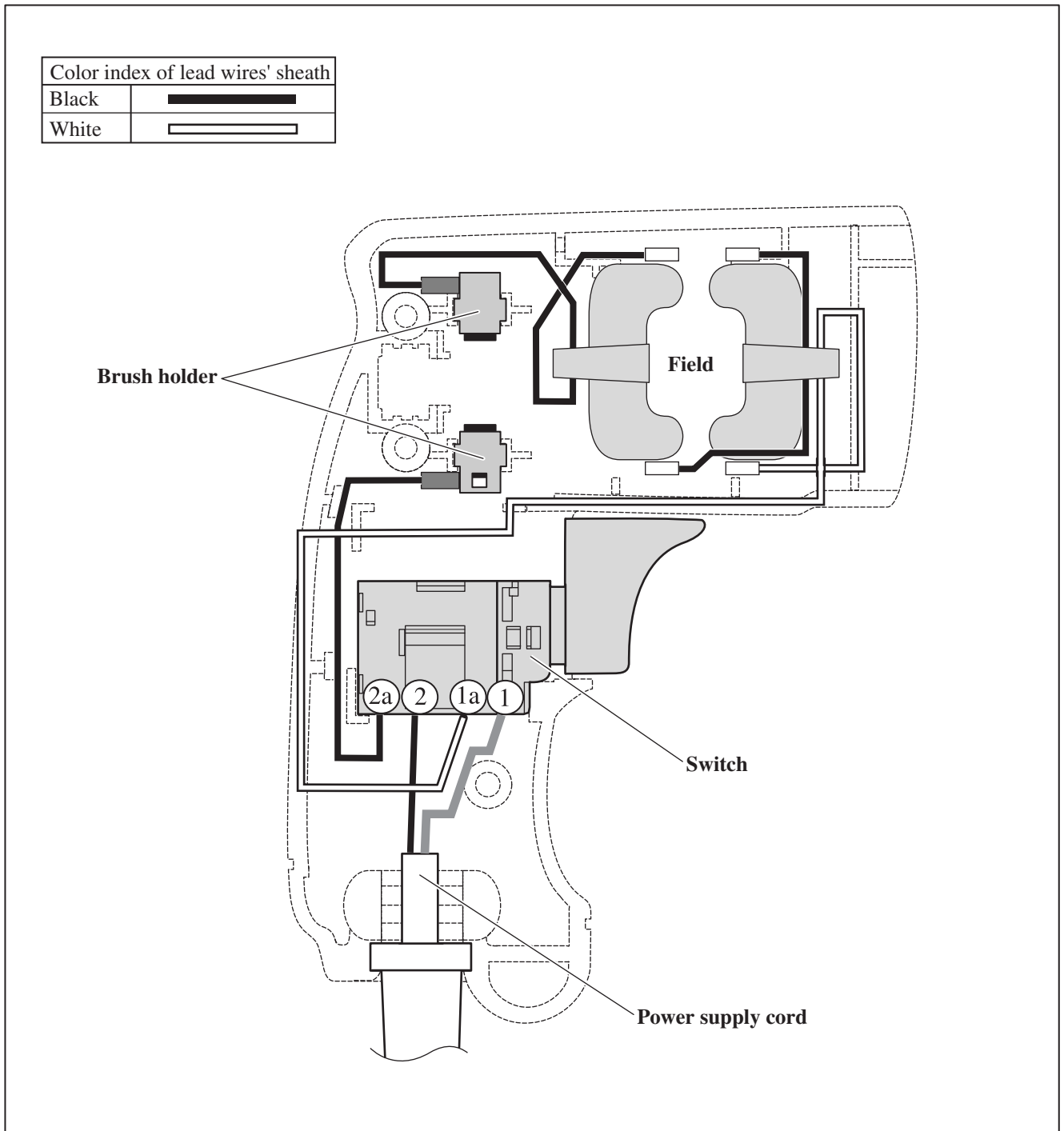

► **Wiring diagram**

Model 6411 (without Variable speed control and Reverse switch)

Machines Without Choke Coil

Important: Do not put slack portion of any Lead wire in the space surrounded by Field and Brush holders. Otherwise Lead wires will be broken by rotating Armature.

Fig. D-2

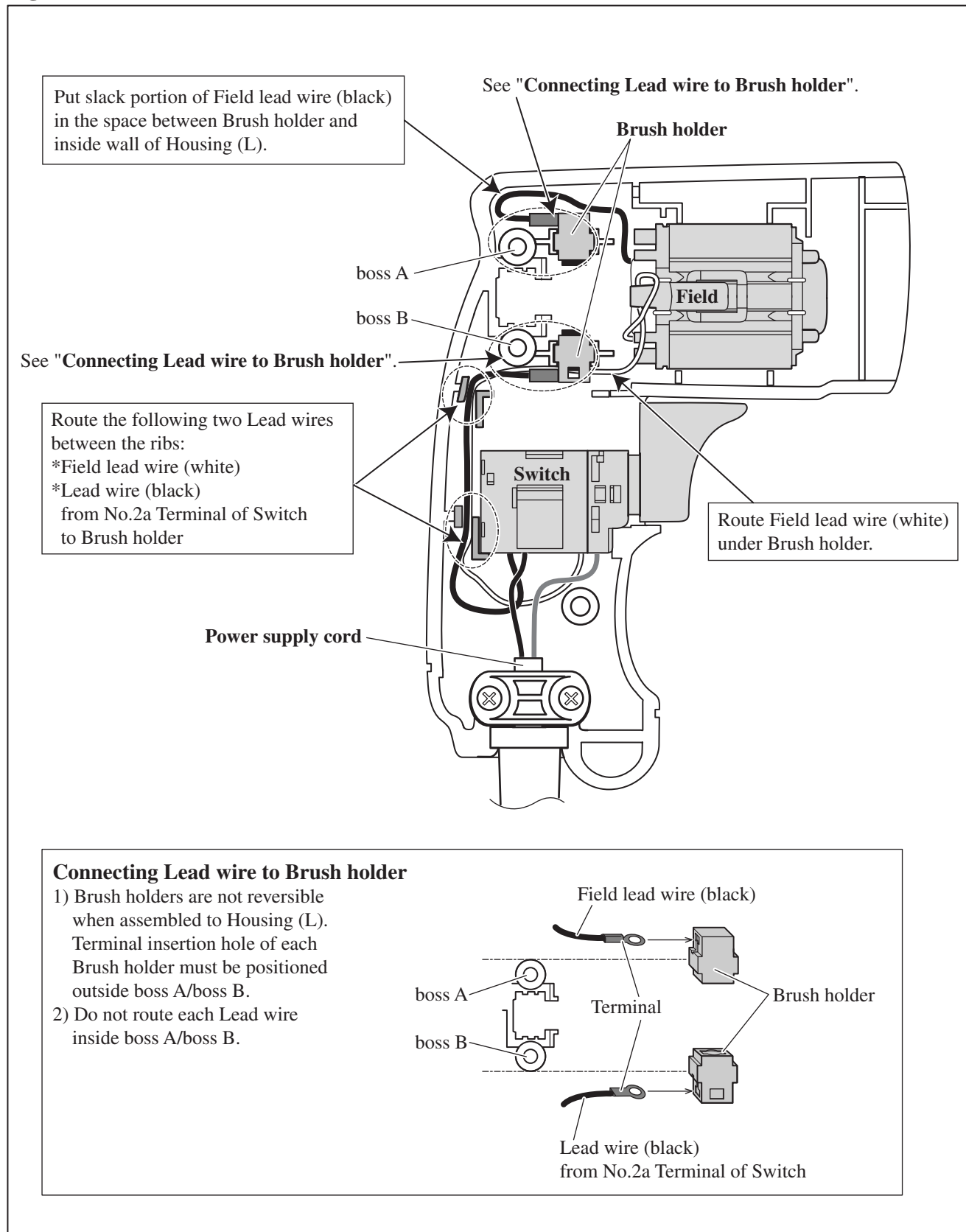

► **Circuit diagram**

Model 6411 (without Variable speed control and Reverse switch)
Machines With Choke Coil

Fig. D-3

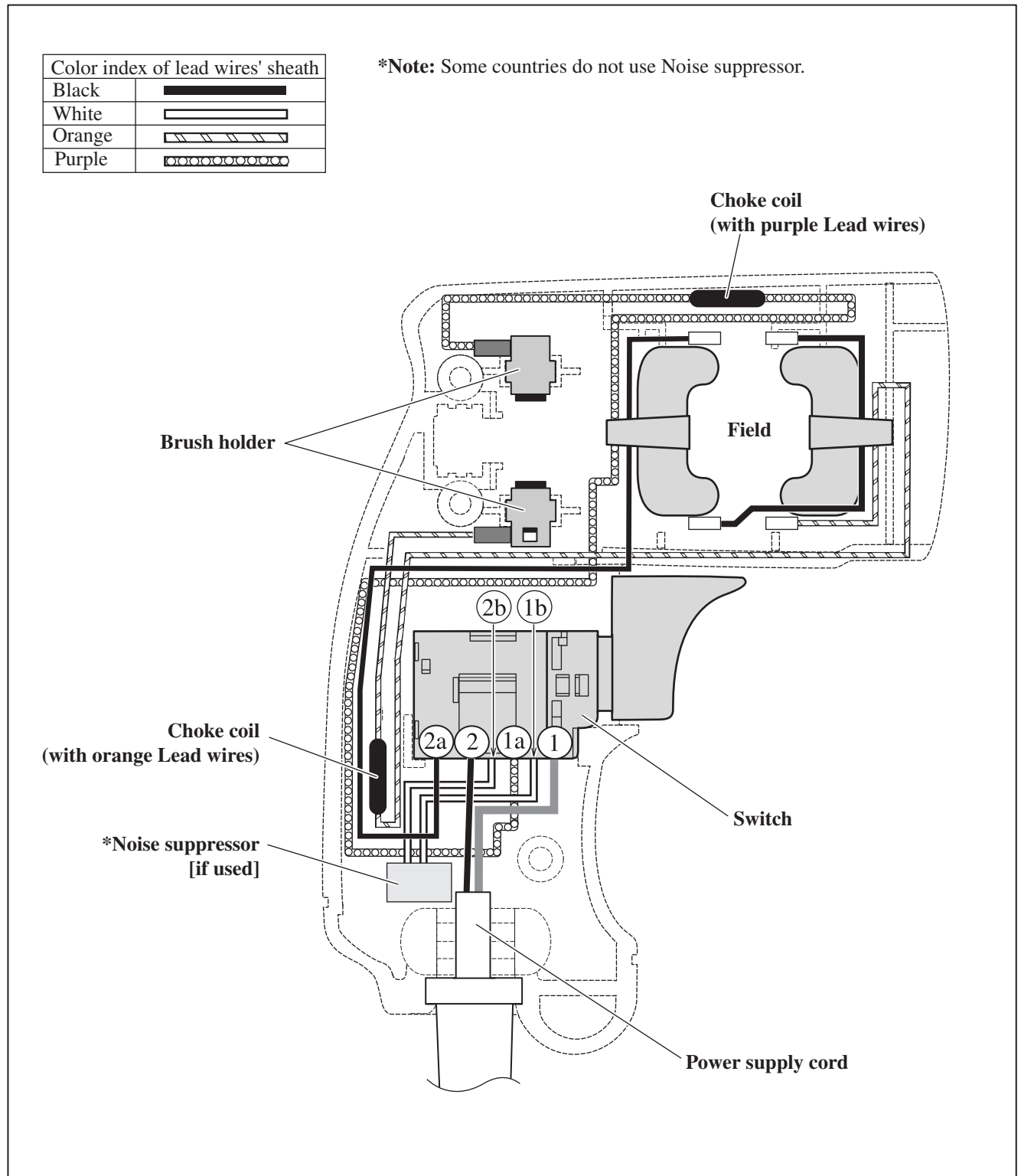

► **Wiring diagram**

Model 6411 (without Variable speed control and Reverse switch)

Machines With Choke Coil

Important: Do not put slack portion of any Lead wire in the space surrounded by Field and Brush holders.
 Otherwise Lead wires will be broken by rotating Armature.

Note: 1) Some countries do not use Noise suppressor.

2) Put Choke coils and Noise suppressor (if used) in place as illustrated in **Fig. D-4**.

Fig. D-4

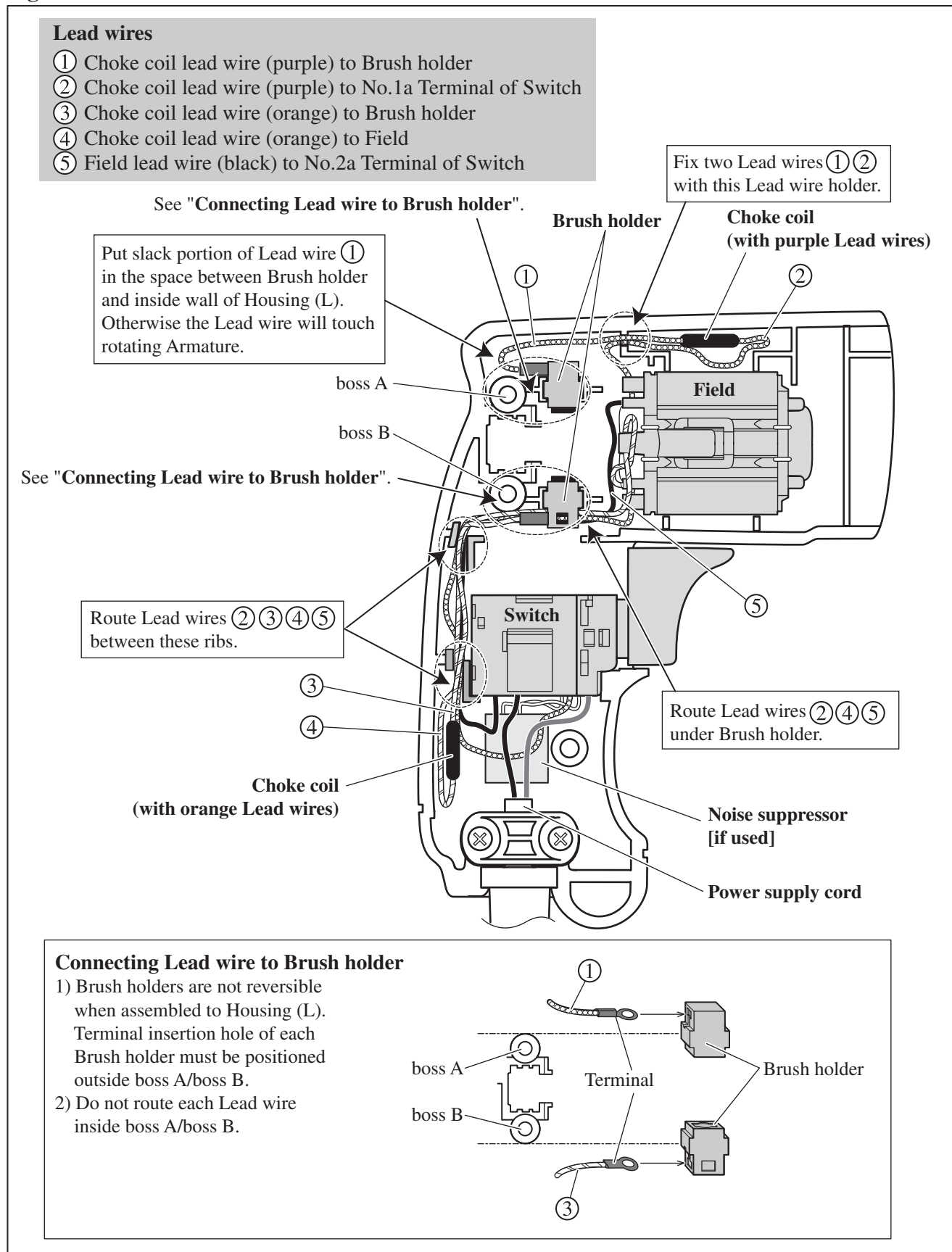

► **Circuit diagram**

Models 6412, 6413, M611 (with Variable speed control and Reverse switch)

Fig. D-5

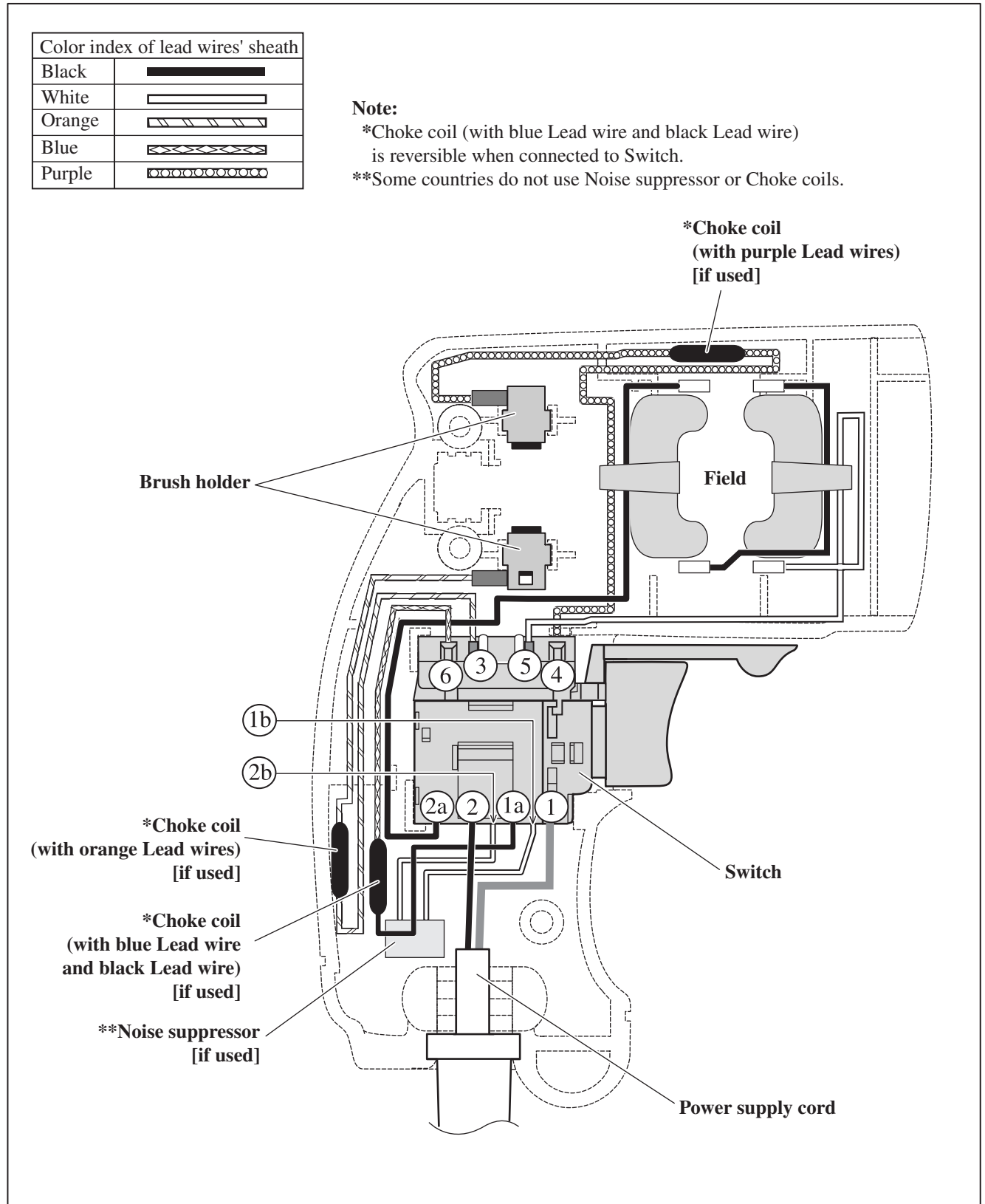

► Wiring diagram

Models 6412, 6413, M611 (with Variable speed control and Reverse switch)

Important: Do not put slack portion of any Lead wire in the space surrounded by Field and Brush holders.
Otherwise Lead wires will be broken by rotating Armature.

Note: 1) Some countries do not use Noise suppressor or Choke coils.

2) Put Choke coils and Noise suppressor (if used) in place as illustrated in **Fig. D-6**.

3) Choke coil (with blue Lead wire and black Lead wire) is reversible when connected to Switch.

Fig. D-6

