

TECHNICAL INFORMATION



PRODUCT

P 1 / 1

Models No. ▶ 6501, 6501X

Description ▶ 6.5 mm High speed drill

CONCEPTION AND MAIN APPLICATIONS

Exceptionally fast, clean drilling of holes with these 4,500 rpm. performer.
Compact and light weight body but, equipped with powerful 230W motor.
Model 6501X is equipped with keyless drill chuck.

Dimensions : mm (")		
Model No.	6501	6501X
Width (W)	63 (2-1/2)	63 (2-1/2)
Height (H)	141 (5-9/16)	141 (5-9/16)
Center height(CH)	16 (5/8)	19 (3/4)
Length (L)	206 (8-1/8)	219 (8-5/8)

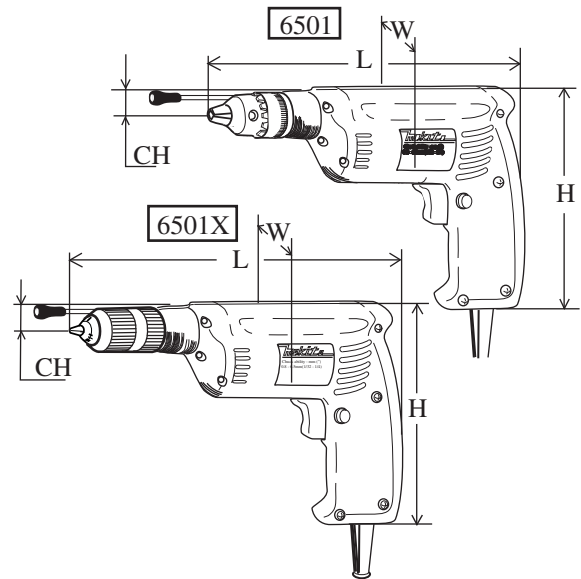

► Specification

Voltage (V)	Current (A)	Cycle (Hz)	Continuous Rating (W)		Max. Output(W)
			Input	Output	
100	2.4	50 / 60	230	120	160
115	2.1	50 / 60	230	120	160
200	1.2	50 / 60	230	120	160
220	1.1	50 / 60	230	120	160
230	1.0	50 / 60	230	120	160
240	1.0	50 / 60	230	120	160

Model No.	6501	6501X
Chuck ability : mm (")	0 - 6.5 (0 - 1/4)	0.8 - 6.5 (1/32 - 1/4)
Drilling capacity : mm (")	in Steel	6.5 (1/4)
	in Wood	9.0 (3/8)
No load speed : (min -1= rpm)	4,500	
Keyless drill chuck	No	Yes
Cord length : m (ft)	2.0 (6.6)	
Net weight :Kg (lbs)	0.9 (2.0)	

► Standard equipment

- * Stopper pole set 1 set
- * Chuck key 1 pc. (only for Mod.6501)

< Note > The standard equipment for the tool shown may differ from country to country.

► Optional accessories

- * Drill bit (for steel) 1.5, 2, 3, 4, 5, 6, 6
- * Drill bit (for wood) M9
- * Keyless drill chuck set