

For Models ▶ 6793D,6794D

Description ▶ Cordless Screwdriver

CONCEPTION AND MAIN APPLICATIONS

Models 6793D and 6794D are identical with the existing Models 6791D and 6792D respectively except that Models 6793D and 6794D have a control circuit to cut off the current automatically when the battery capacity decreases to a certain level. They are ideal for application which requires accurate fastening of screws.

(Note)

Models 6793D and 6794D do not include a fast charger and battery cartridge.

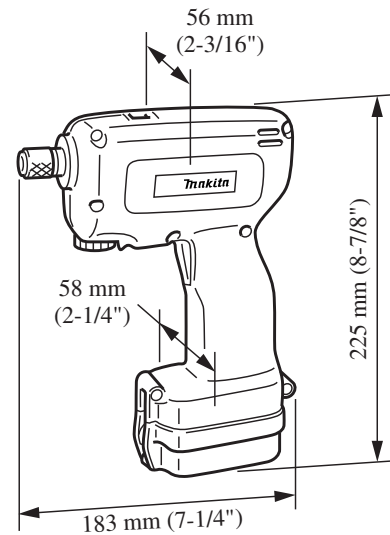

► Specifications

Model No.	6793D	6794D
Capacities Nut/machine screw	4mm-8mm(5/32"-5/16")	4mm-6mm(5/32"-1/4")
No load speed	400R/min	650R/min
Fastening torque	20kg·cm-120kg·cm(1.4ft·lbs-8.7ft·lbs)	20kg·cm-80kg·cm(1.4ft·lbs-5.8ft·lbs)
Net Weight	1.4kg(3.1 lbs)	1.4kg(3.1 lbs)
Output	D.C. 9.6V	D.C. 9.6V
Charging time	Approx. 1hour	Approx. 1hour

► Standard equipment

None

► Optional accessories

Various sizes of Phillips bits, Various sizes of slotted bits, Various sizes of socket bits, Keyless chuck 10, Battery cartridge 9100, 9100A, 9101, 9101A Fast charger DC9700, DC1201, DC9015, DC9112

1 Circuit diagram

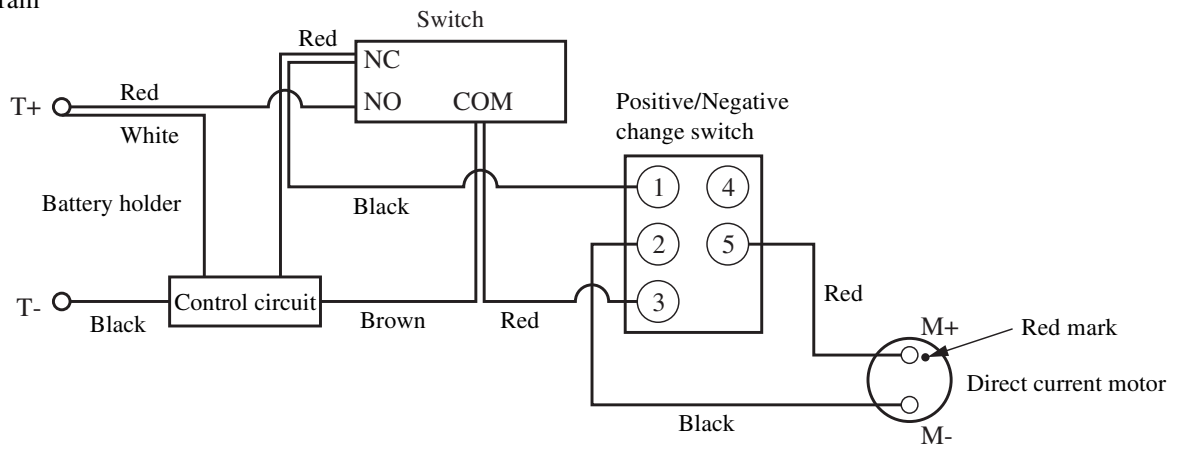

2 Others are the same as those of 6791D/6792D.