

TECHNICAL INFORMATION



PRODUCT

P 1 / 10

Models No. ▶ 6796D/FD, 6797D/FD, 6798D/FD

Description ▶ 9.6 V Cordless screwdriver

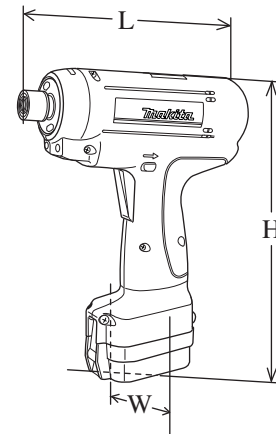

CONCEPTION AND MAIN APPLICATIONS

The series of the above cordless screwdrivers have been developed for automobile assembling line where the precise fastening torque is required.

The precise fastening torque thanks to

- * Battery power warning lamp
- * Auto stop when continuous operation disregarding the above warning.

The easy and comfortable working thanks to

- * Palm fitting soft grip
- * Lighting up front lamps for easy approach to the screwing point in dark. (only FD models)

Dimensions : mm (")	
Length (L)	174 (6-27/32)
Height (H)	240 (9-7/16)
Width (W)	58 (2-9/32)

► Specification

Model No.		6796D/DF	6797D/DF	6798D/DF
Battery	Cell	Ni-Cd	Ni-Cd	Ni-Cd
	Voltage	9.6	9.6	9.6
	Capacity	2.0	2.0	2.0
No load speed : (min -1= rpm)		320	320	320
Driving shank : mm (")		6.35 (1/4) Hex	6.35 (1/4) Hex	6.35 (1/4) Hex
Fastening torque	N.m	1 - 5	2 - 8	6 - 12
	Kgf.cm	10 - 51	20 - 82	61 - 122
	in.lbs	8.9 - 44	18 - 71	53 - 106
Electric brake		Yes	Yes	Yes
Reverse switch		Yes	Yes	Yes
* Net weight : Kg (lbs)		1.4 (3.1)	1.4 (3.1)	1.4 (3.1)

* Net weight : including battery

► Optional accessories

- | | | |
|------------------------|-----------------------|---|
| * Various philips bits | * Battery 9100 | * Charger DC1411 |
| * Various socket bits | * Battery 9102 | * Charger DC1801 |
| * Bit piece | * Battery 9102A | * Automotive charger DC1422 |
| * Protector | * Fast charger DC1439 | * Adjust grip for pre-setting of torque |

< 1 > Disassembling sleeve section

Disassemble ring spring 10 with retaining ring plier from the groove of spindle. Then flat washer 11, compression spring 13 and sleeve can be removed from spindle as illustrated in Fig. 1.

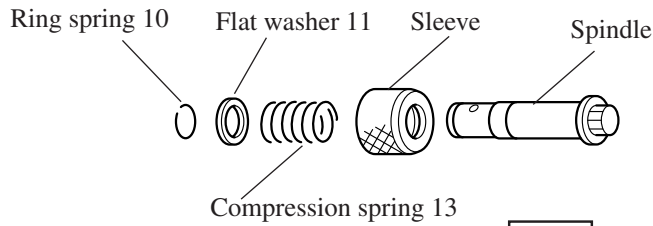

Fig. 1

< 2 > Separating DC motor from gear section

Hold gear section and turn DC motor anti-clockwise as illustrated in Fig.2. So, DC motor can be removed from gear assembly.

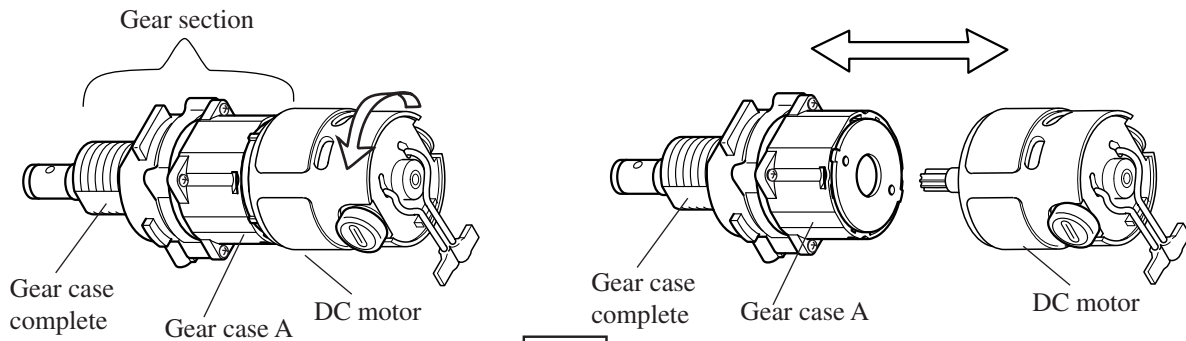

Fig. 2

< 3 > Disassembling gear section

- (1) Turn the lock washer anti-clockwise with screwdriver hitched into any of its two punched holes. Then, the lock washer can be separated from gear case A by pulling out with the screwdriver as illustrated in Fig. 3.

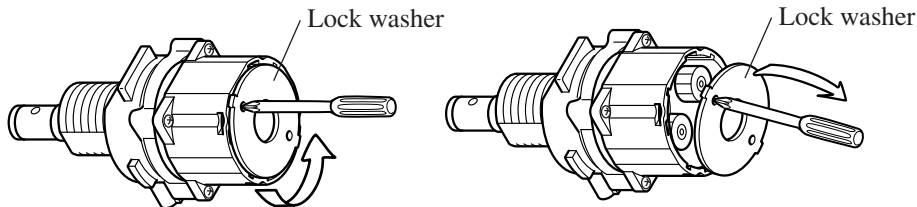

Fig. 3

- (2) Remove the following parts from gear case A as illustrated in Fig. 3A.

- * Spur gear 17 x 3 pcs.
- * Spur gear 15 complete (with 3 shafts)
- * Spur gear 10 x 5 pcs.
- * Spur gear 15 complete (with 5 shafts)

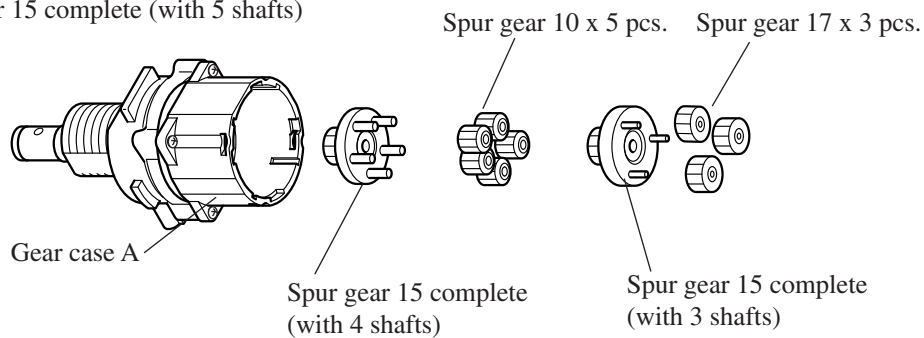
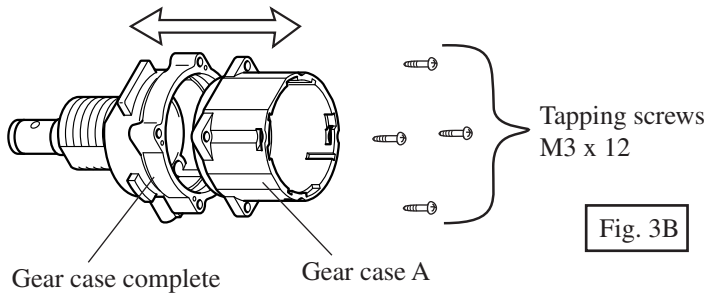

Fig. 3A

- (3) Take off 4 pcs. of tapping screws M3 x 12. And separate gear case A from gear case complete as illustrated in Fig. 3B.



- (4) Remove the following parts from gear case A as illustrated in Fig. 3C.

- * Flat washer 18
- * **Steel ball 3 x 38 pcs.**
- * Internal gear 35
- * Spur gear 10 x 5 pcs.
- * Carrier (with 5 shafts)

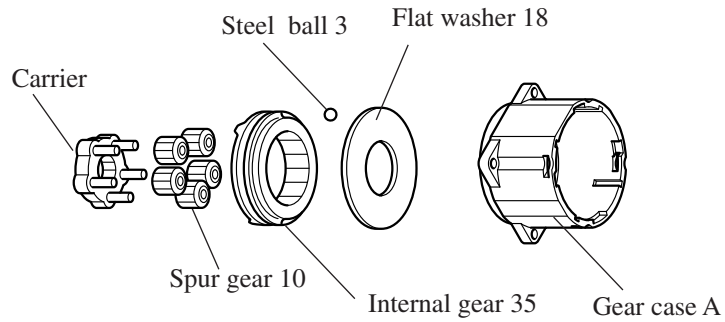

< Note > 38 pcs. of steel balls 3 are assembled. Check the quantity of them, when assembling.

< 4 > Disassembling switch

- (1) Unscrew the screw fastening micro switch, and turn the micro switch with pulling it up as illustrated in Fig. 4. Then, micro switch can be separated from switch.

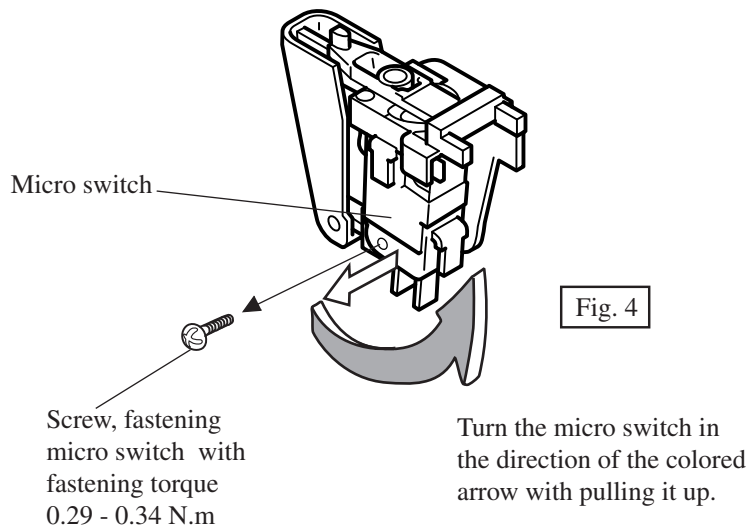

< 4 > Assembling spring holder section

Assemble spring holder by turning it clockwise at least 4 turns as illustrated in Fig. 4.

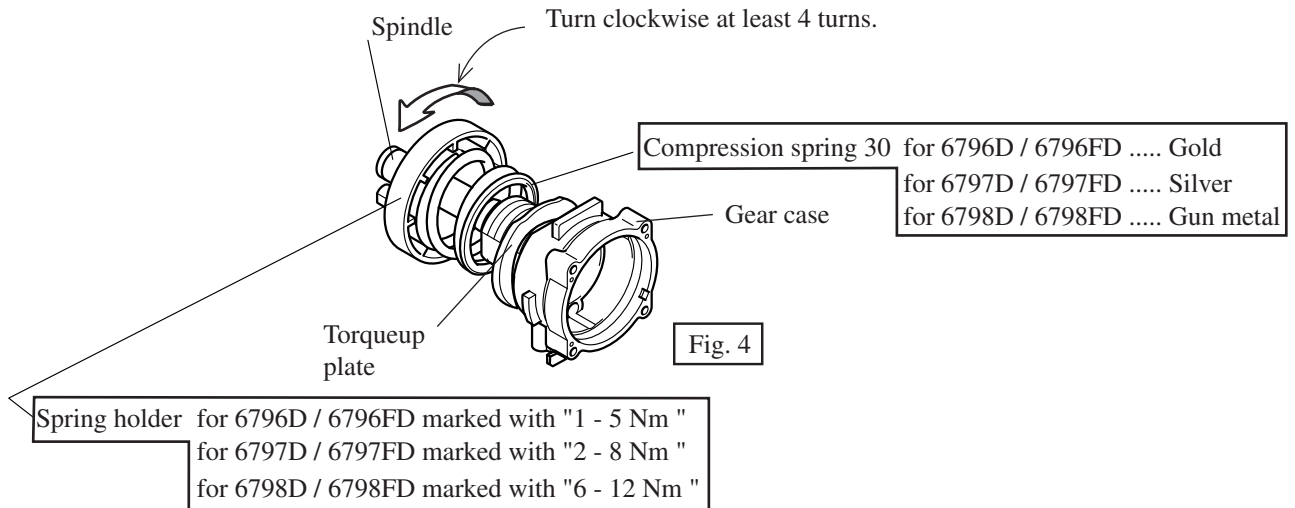

Spring holder and compression spring 30 to be assembled to spring holder section are distinguished as mentioned above.

Be careful not to assemble them to the wrong model.

< 5 > Assembling and adjusting switch unit

Adjust the switch unit's position against torqueup plate by sliding holder plate, so that the gap between torqueup plate and switch unit comes to $1.4 \pm 0.2\text{mm}$ as illustrated in Fig. 5A.

No.1R289 Adjusting jig is required for this work. After the adjusting, fix holder plate to which switch unit is assembled, on gear case complete.

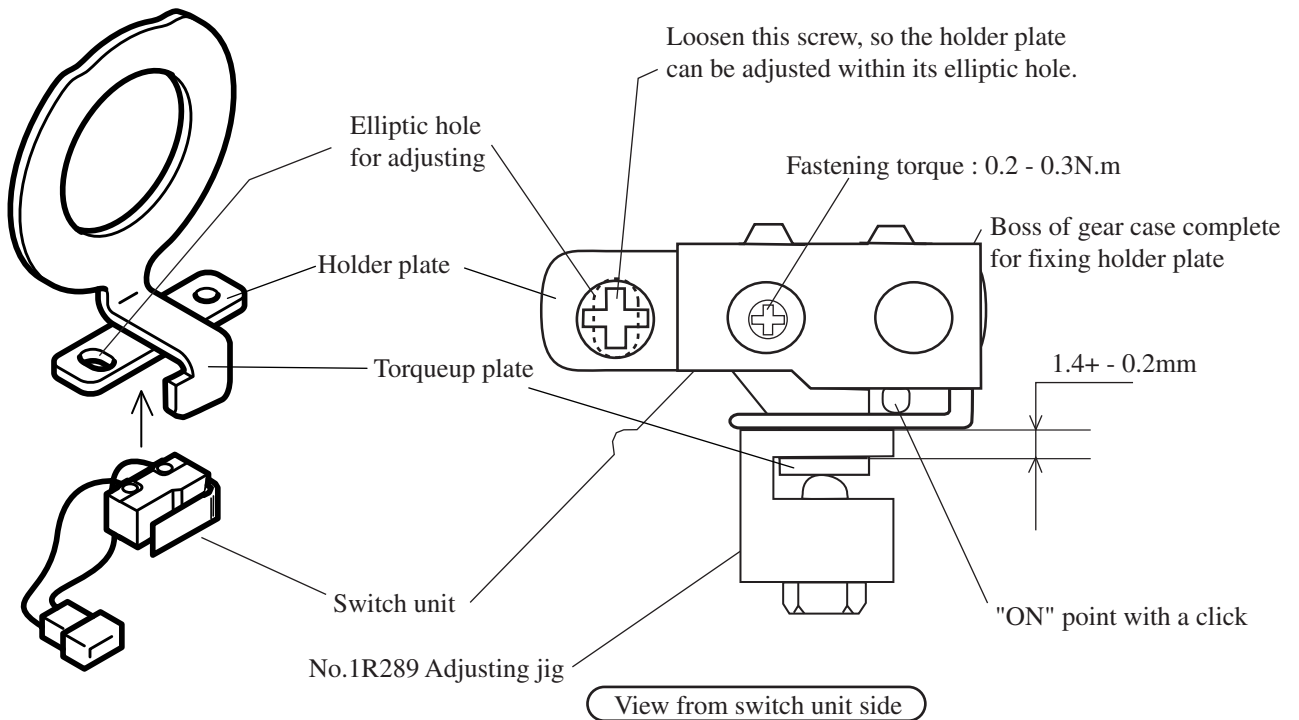

< 6 > Assembling cam section

(1) Assemble the following parts to gear case A as illustrated in Fig. 6A.

- * Flat washer 18
- * **Steel ball 3 x 38 pcs.**
- * Internal gear 35
- * Spur gear 10 x 5 pcs.
- * Carrier (with 5 shafts)

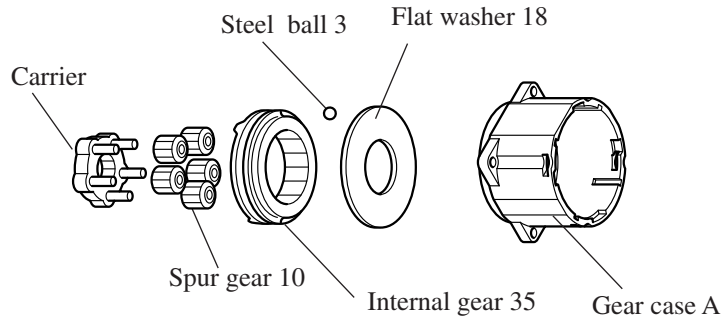

< Note > 38 pcs. of steel balls 3 are assembled. Check the quantity of them, when assembling.

Fig. 6A

(2) Assemble the gear case A to which the above 5 parts have been assembled, to gear case complete by fastening with 4 tapping screws as illustrated in Fig. 6B.

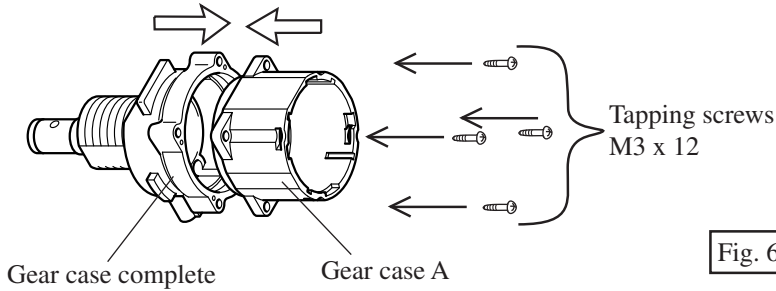

Fig. 6 B

(3) Assemble the gears to gear case A as illustrated in Fig. 6C, and assemble lock washer as illustrated in Fig. 6D.

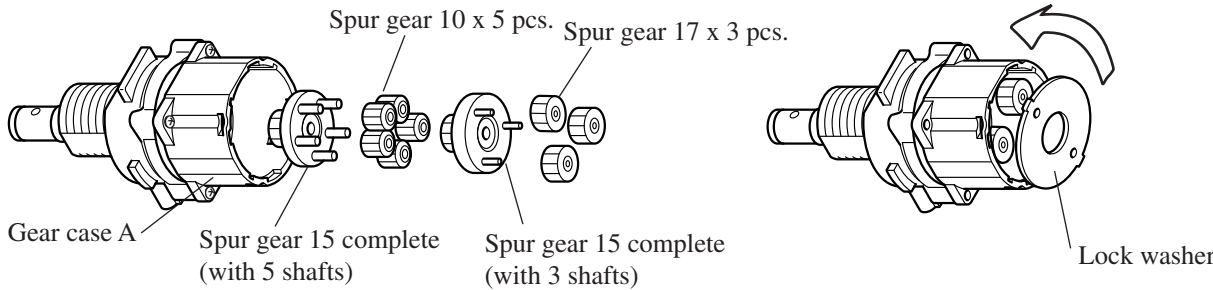

Fig. 6 C

Fig. 6 D

4) Insert 3 pcs. of steel balls 5 into the 3 holes of gear case complete, and then insert 3 pcs. of pin 5.0 into the same holes as illustrated in Fig. 6E.

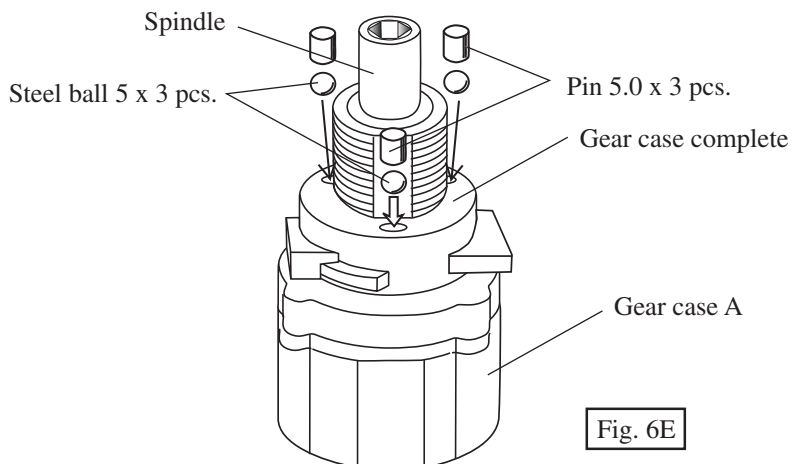

Fig. 6E

< 7 > Lubrication

Apply MAKITA grease N No.2 to the parts marked with black triangle illustrated in Fig. 7.

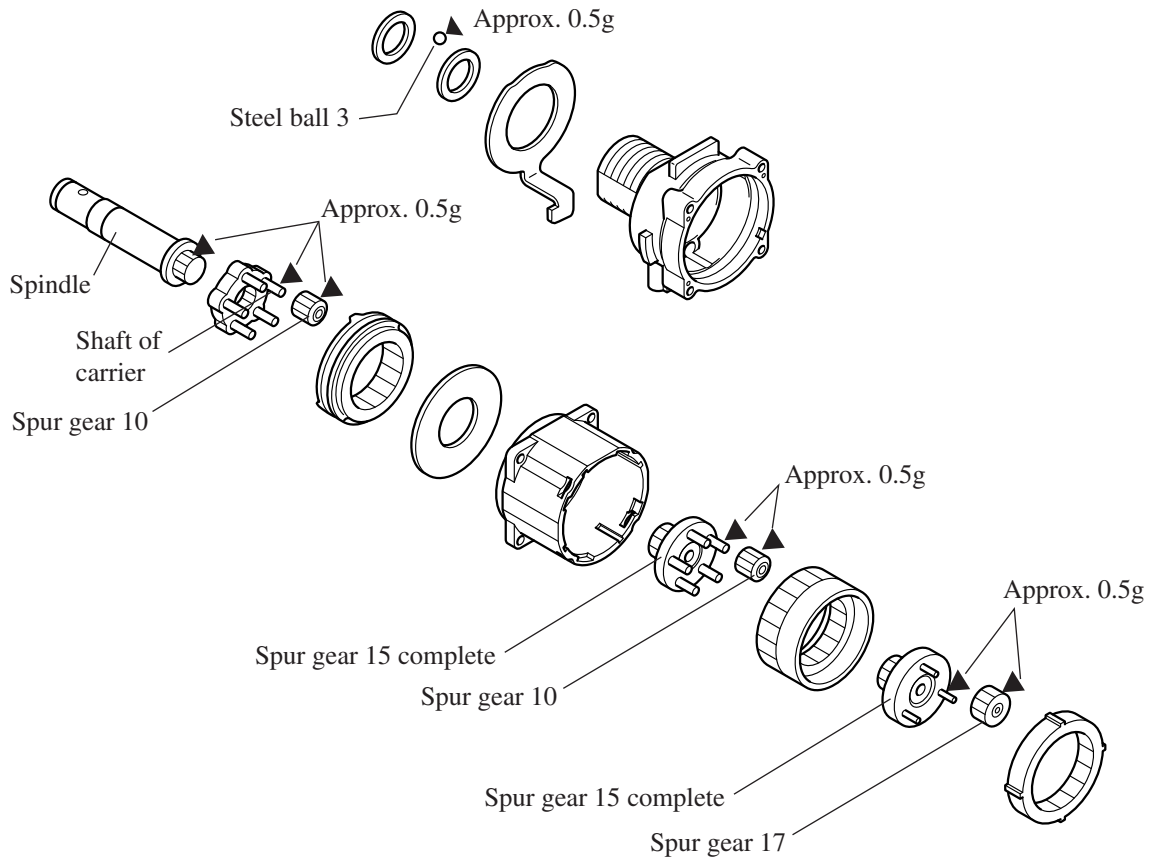
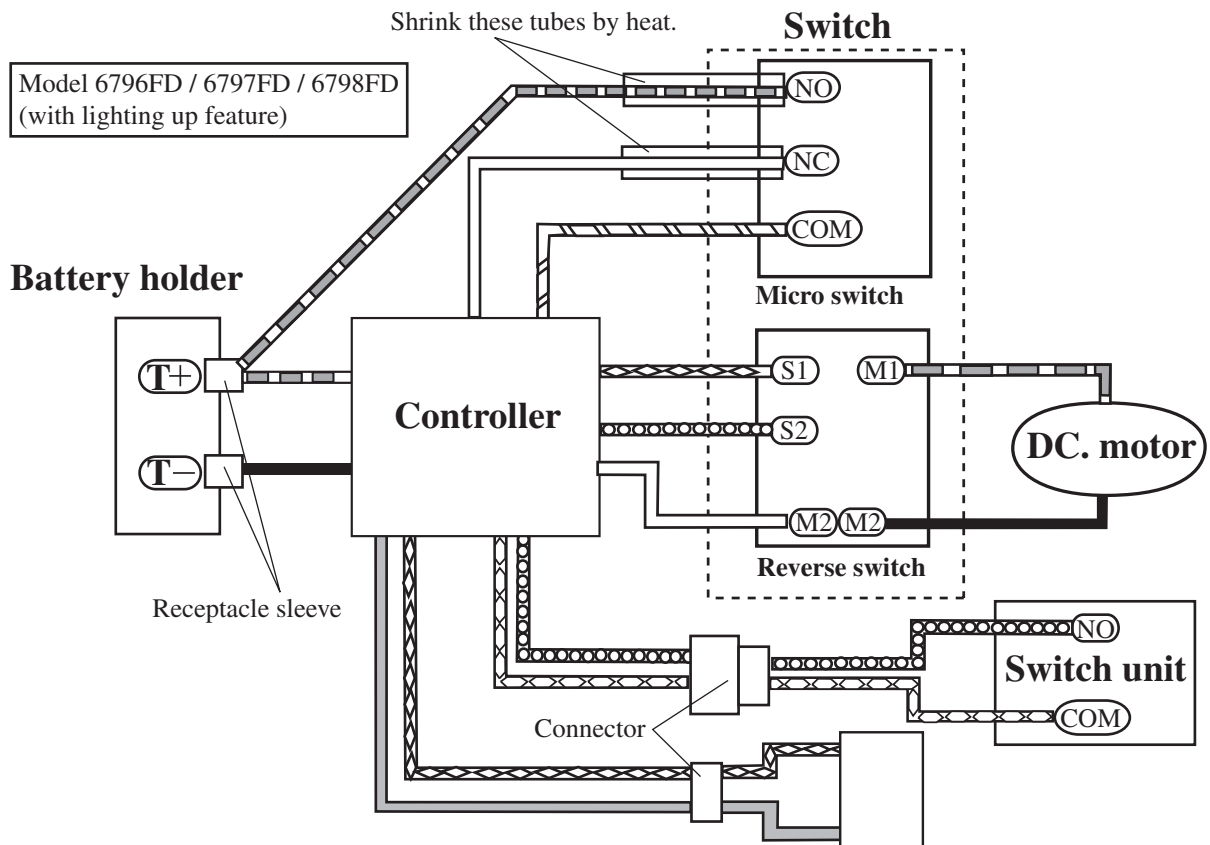
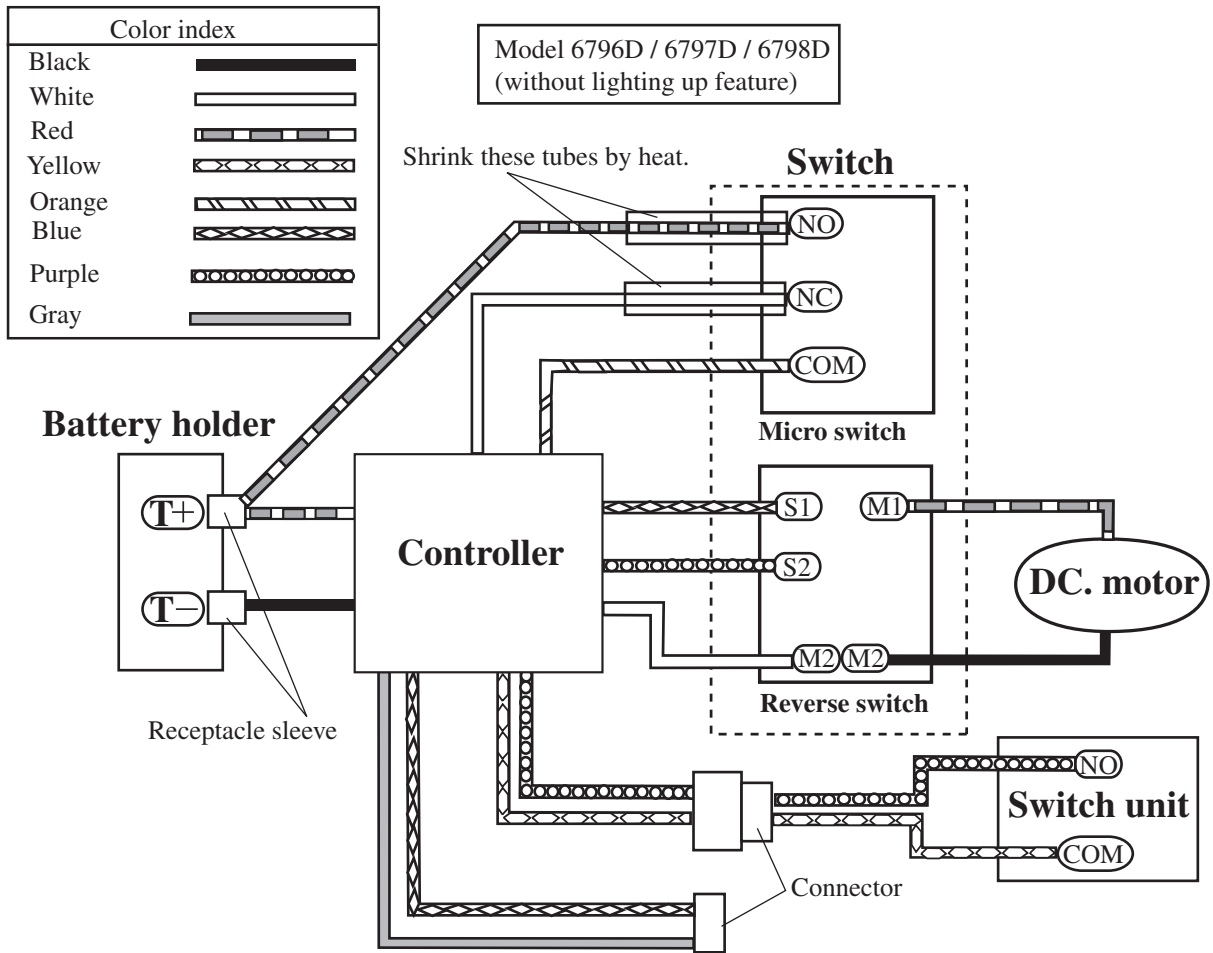

Fig. 7



LED circuit complete
(Circuit for lighting up feature)

▶ Wiring diagram

For model 6796D, 6797D, 6798D
6796FD, 6797FD, 6798FD

(1) Connecting to switch

Connect lead wires and receptacles to switch as illustrated in Fig. 8, and fix them with lead holder.

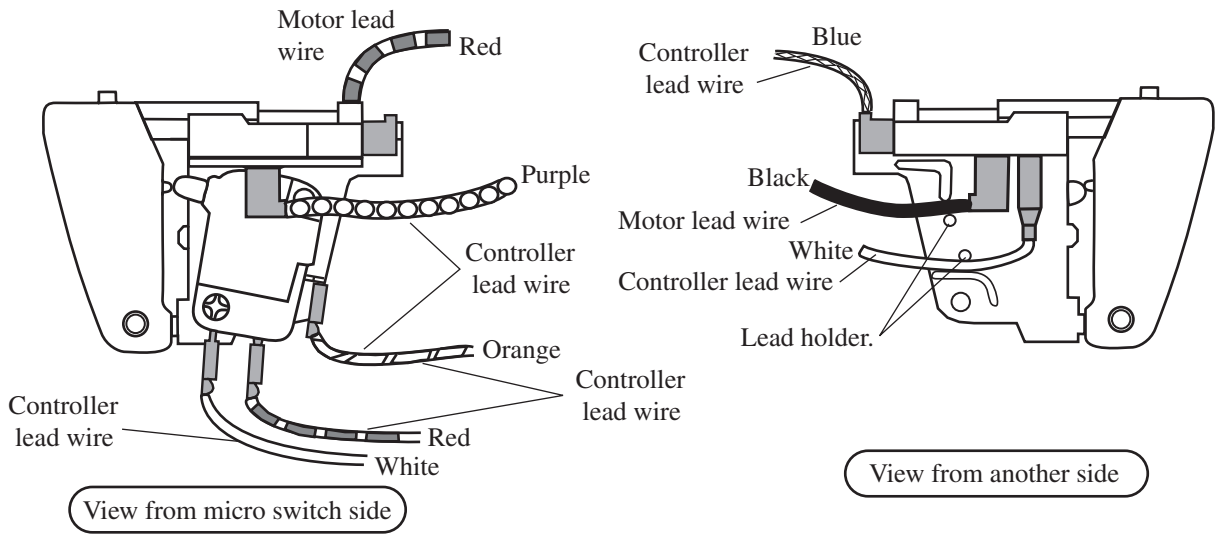

Fig. 8

(2) Connecting to battery holder

Connect the flag type receptacle equipped with receptacle sleeve, as illustrated in Fig. 9.

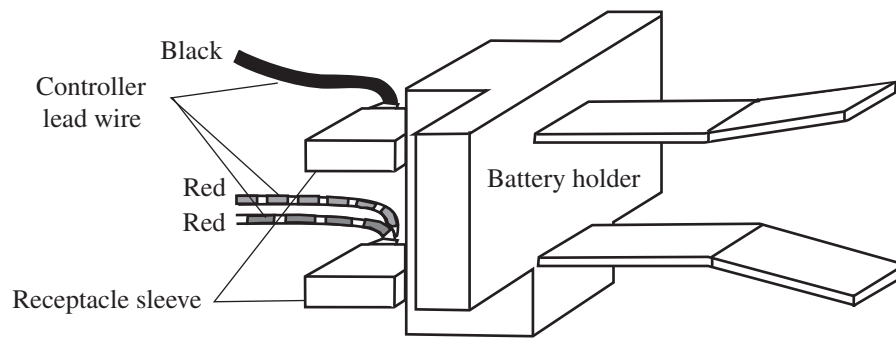
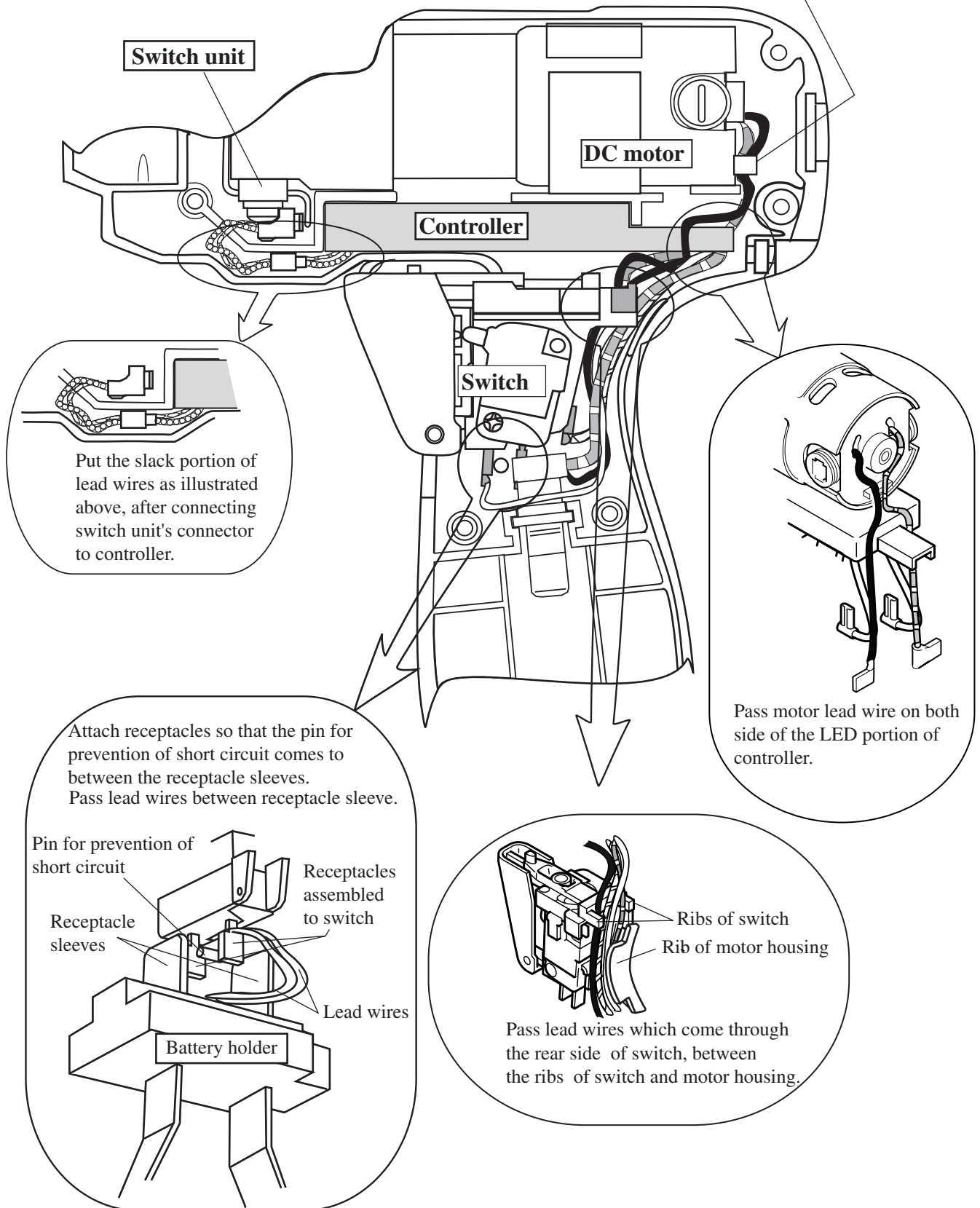

Fig. 9

Wiring in motor housing
Model 6796D/ 6797D/ 6798D

Fix motor lead wire
with lead holder.



Wiring in motor housing
Model 6796FD/ 6797FD/ 6798FD

Fix motor lead wire
with lead holder.

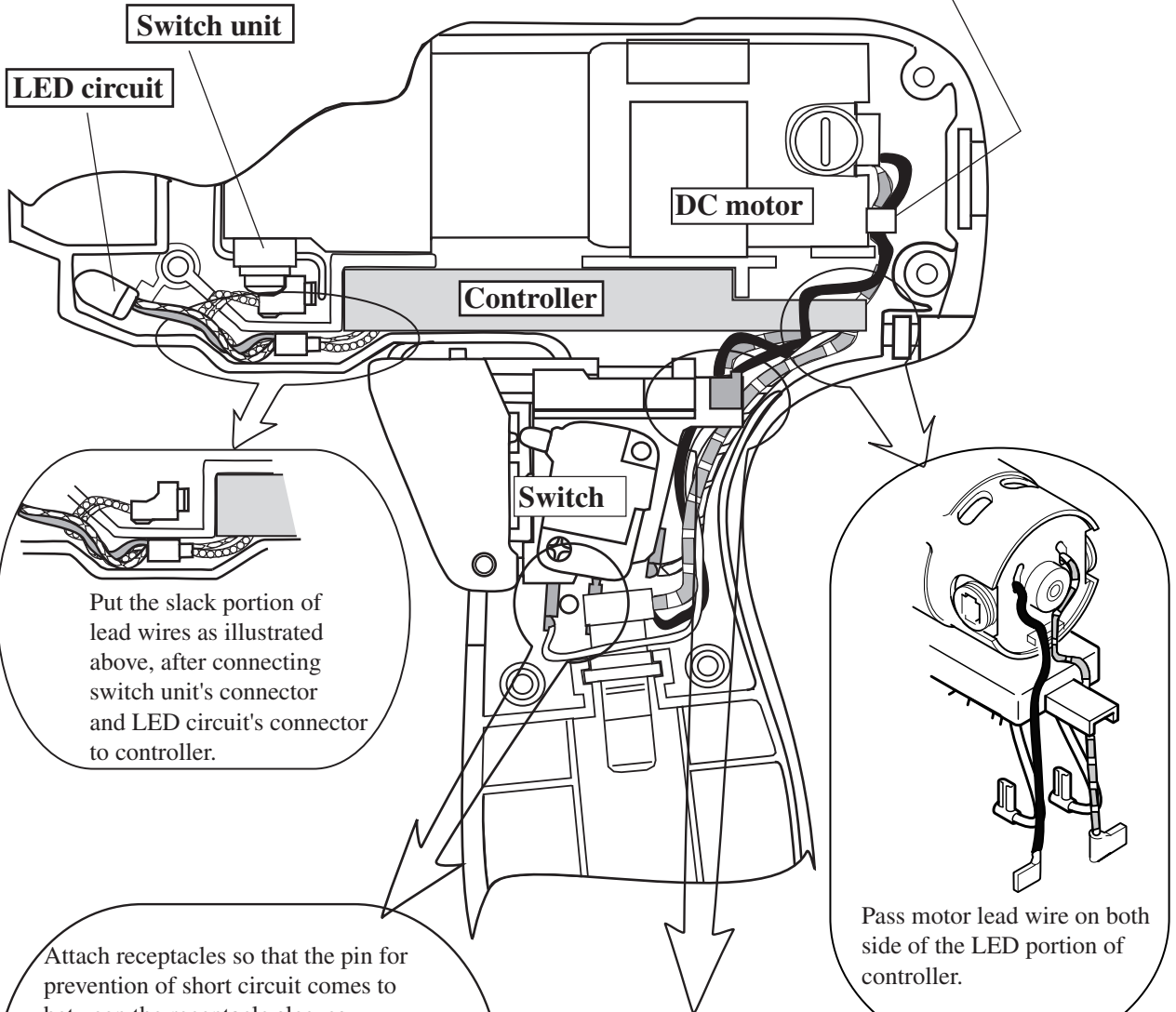

Put the slack portion of lead wires as illustrated above, after connecting switch unit's connector and LED circuit's connector to controller.

Pass motor lead wire on both side of the LED portion of controller.

Attach receptacles so that the pin for prevention of short circuit comes to between the receptacle sleeves.
Pass lead wires between receptacle sleeve.

Pin for prevention of short circuit
Receptacle sleeves
Receptacles assembled to switch
Lead wires
Battery holder

Ribs of switch
Rib of motor housing

Pass lead wires which come through the rear side of switch, between the ribs of switch and motor housing.