

TECHNICAL INFORMATION

Makita

New Tool

Models No. ▶ 6820V

Description ▶ Dry wall Screw Driver

CONCEPTION AND MAIN APPLICATIONS

Compared with Model 6801DBV, this machine has a more powerful motor, which results in improvement of work efficiency. This machine is easy to grip and has shorter total length for better operation. New type of clutch eliminates annoying sounds produced when tightening of screws has been completed, and the noise of motor cooling wind has been reduced for your comfortable use.

Used for attachment of boards (plaster, asbestos, plastic), etc.

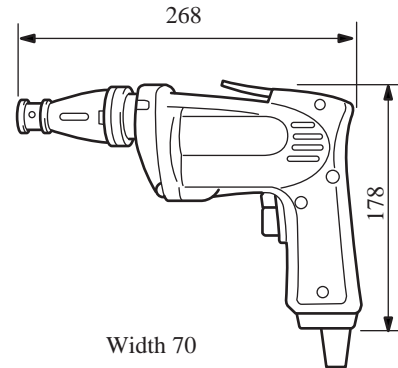

▶ Specifications

Voltage(V)	Current(A)	Frequency(Hz)	Consumed power(W)	Rated output(W)	Max. output(W)
100	6	50-60	570	280	460
115	5.2	50-60	570	280	460
200	3.0	50-60	570	280	460
220	2.7	50-60	570	280	460
230	2.6	50-60	570	280	460
240	2.5	50-60	570	280	460

No load speed	0-4000/min
Dry wall screw	5 mm
Tex screw	6 mm
Net Weight(kg)	1.3 kg
Cord length(m)	2.5 m

▶ Standard equipment

Bit 2-25

Magnetic connecting bit 6.35-60

▶ Optional accessories

Bit 1-25

Bit 2-25

Bit 3-25

Magnetic connecting bit 6.35-60

Connecting bit 6.35-60

The standard equipment for the tools shown may differ from country to country

▶ Repair

- (1) To disassemble the spindle, pull the bit out, detach the dust-proof ring from the spindle, and pull the spindle out to the gear side. (See the figure blow.)
- (2) Except the above-mentioned step, follow the procedures for 6801DBV.

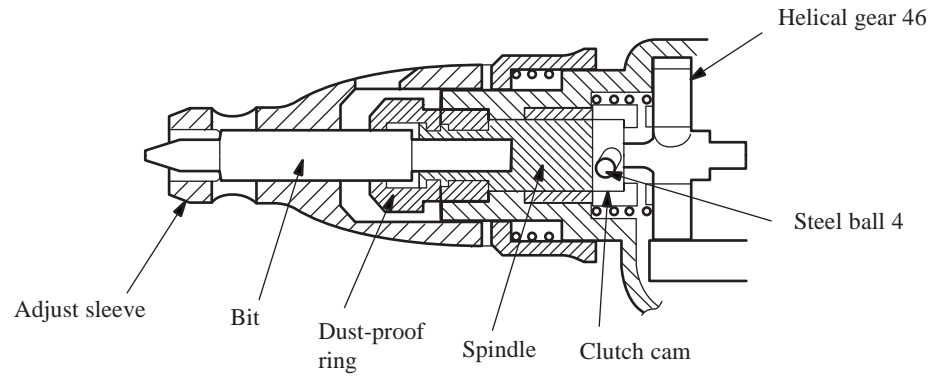

► Circuit diagram

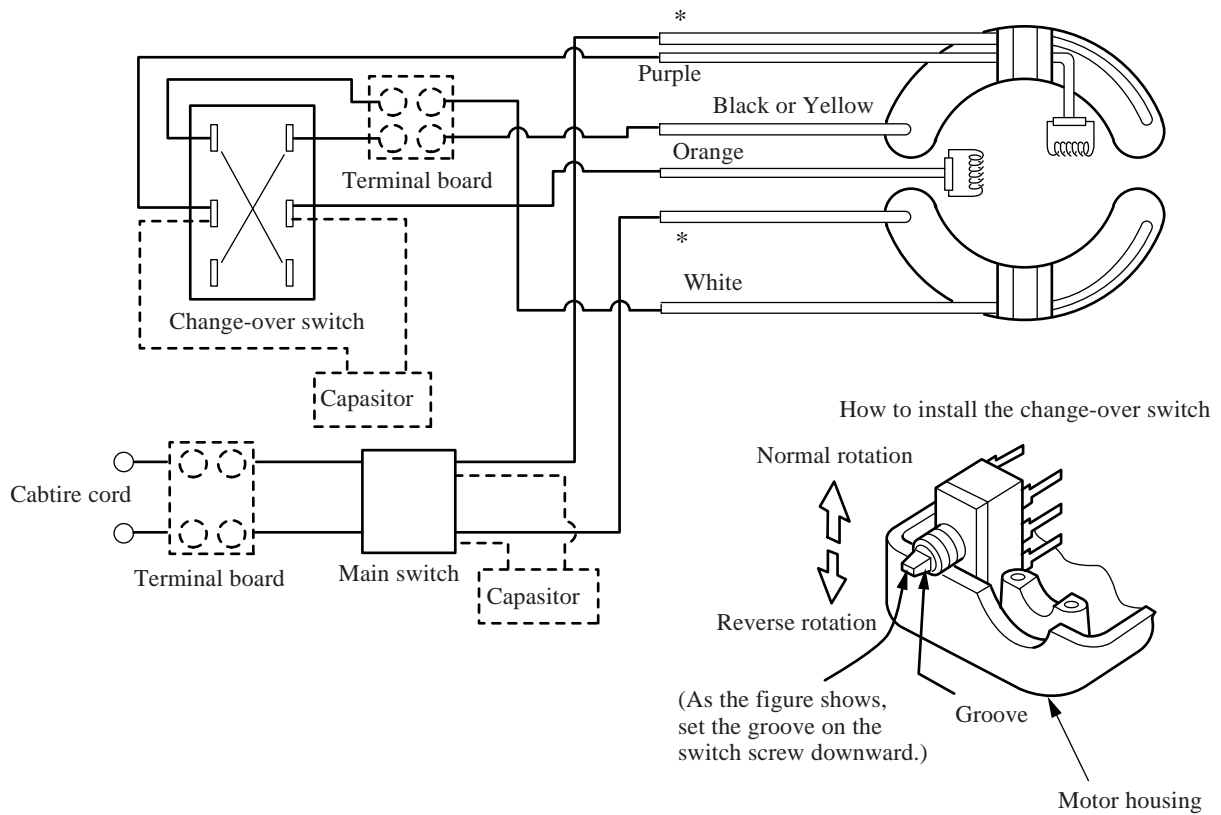

Note 1) As terminal numbers are not indicated on the change-over switch, confirm the position with the groove on the screw. (See the figure above.)

Note 2) Specifications for the parts drawn in broken lines differ according to nations.

Note 3) Filed lines marked with * differ according to voltages as listed below.

Voltage	Color
100V	Black
105-130V	Sky blue or Gray or Black
200V	Brown
220V	Blue
230-250V	Red