

TECHNICAL INFORMATION



Models No. ▶ 6823, 6824, 6825

Description ▶ Drywall screwdriver

CONCEPTION AND MAIN APPLICATIONS

The above new faces are superior to other products in driving speed, durability and comfortable work. The high rotation speed has enabled you to fasten screws as quick as lightning.

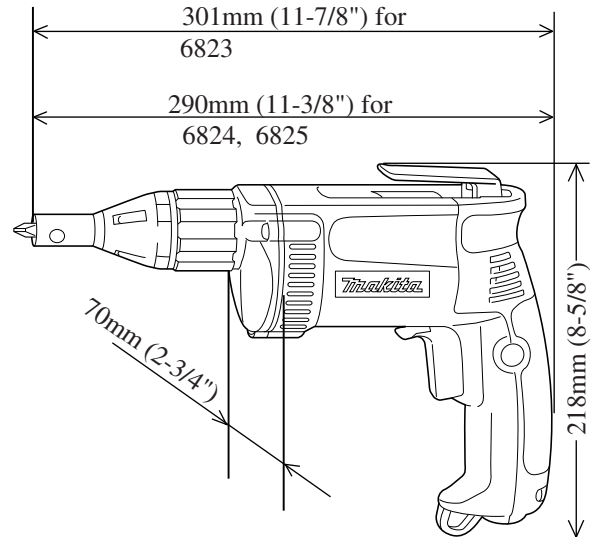

► Specifications

The following electrical data are common to 6823, 6824 and 6825.

Voltage (V)	Current (A)	Cycle (Hz)	Continuous Rating (W)		Max. Output(W)
			Input	Output	
100	6.0	50 - 60 Hz	570	260	570
110	5.2	50 - 60 Hz	570	260	570
120	6.5	50 - 60 Hz	(710)	340	590
220	2.7	50 - 60 Hz	570	260	570
230	2.6	50 - 60 Hz	570	260	570
240	2.5	50 - 60 Hz	570	260	570

Model No.	6823	6824	6825
Protection from electric shock	by Grounding	by Grounding	by Grounding
No load speed (rpm.)	0 - 2,500	0 - 4,500	0 - 6,000
Driving shank	6.35mm (1/4") Hex	6.35mm (1/4") Hex	6.35mm (1/4") Hex
Driving capacity	Dry wall screw	6mm (1/4")	5mm (3/16")
	Teks screw	6mm (1/4")	6mm (1/4")
Silent clutch	Yes	Yes	Yes
Cord length	2.5m(8.2ft)	2.5m(8.2ft)	2.5m(8.2ft)
Weight	1.5 Kg (3.4 lbs)	1.4 Kg (3.1 lbs)	1.4 Kg (3.1 lbs)

► Standard equipment

Philips insert bit 2-25 1 pc.
Magnetic connect bit 6.35 - 76.... 1 pc.

The standard equipment shown may differ from country to country.

► Optional accessories

Philips insert bit 1-25, 2-25, 3-25
Magnetic connect bit 6.35 - 76, 6.35 - 60
Adjust sleeve complete for magnetic connect bit 6.35 - 60

▶ Repair

- < 1 > When installing ring 20, its grooved surface has to be in contact with spindle.
(see Fig.1.)

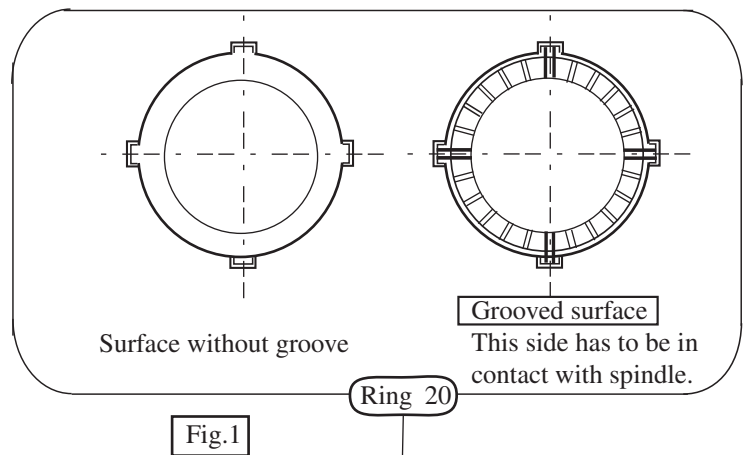

- < 2 > When installing thrust needle bearing 821, its thick washer has to be faced to gear complete.
(see Fig.2.)

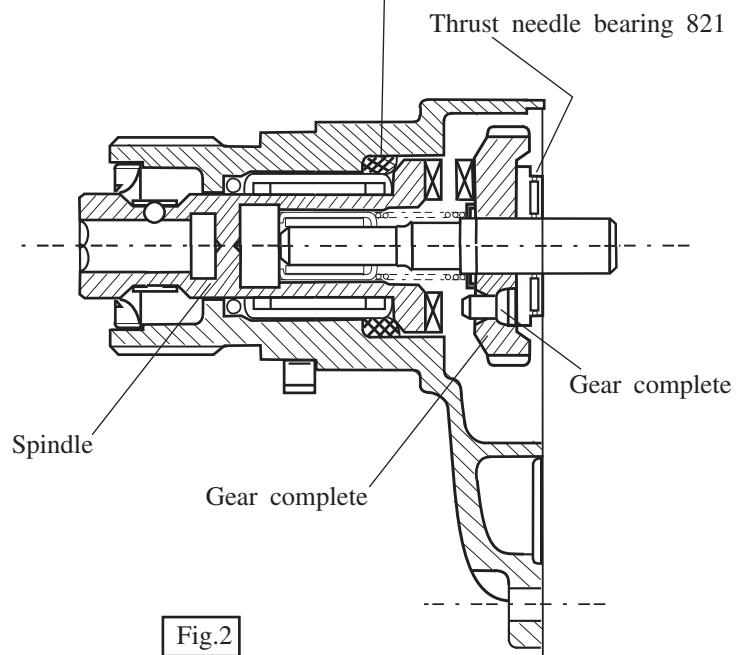

- < 3 > Insert compression spring 8 into spindle by turning it with thick axis of gear complete.
(see Fig.3.)

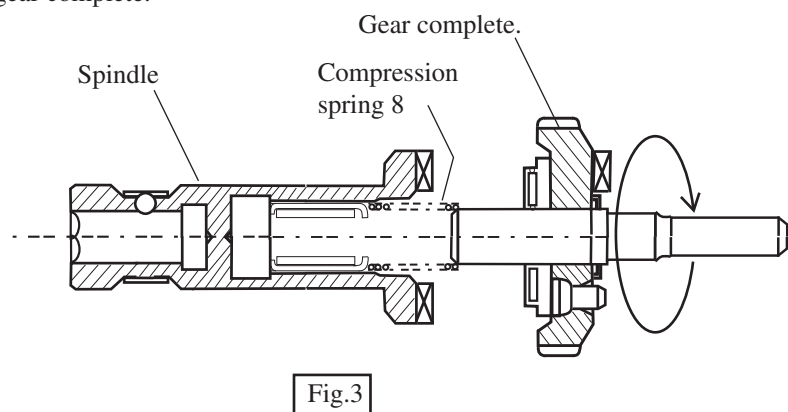

< 4 > When replacing carbon brush, be sure if it is installed on motor housing properly.
And then install handle cover onto motor housing.
(see Fig.4.)

< Properly installed carbon brush >

< Incompletely installed carbon brush >
Correct with your finger to install properly.

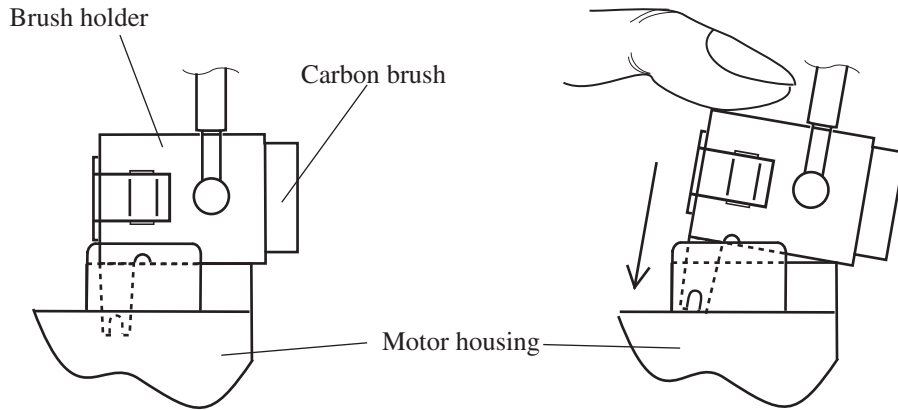

Fig.4

< 5 > Check if spindle keep still during no load operation.
If the spindle would start to move, replace compression spring 8 (1 pc.),
flat washer 8 (2 pcs.) and pin 4 (3 pcs.) as a set.
(see Fig.5.)

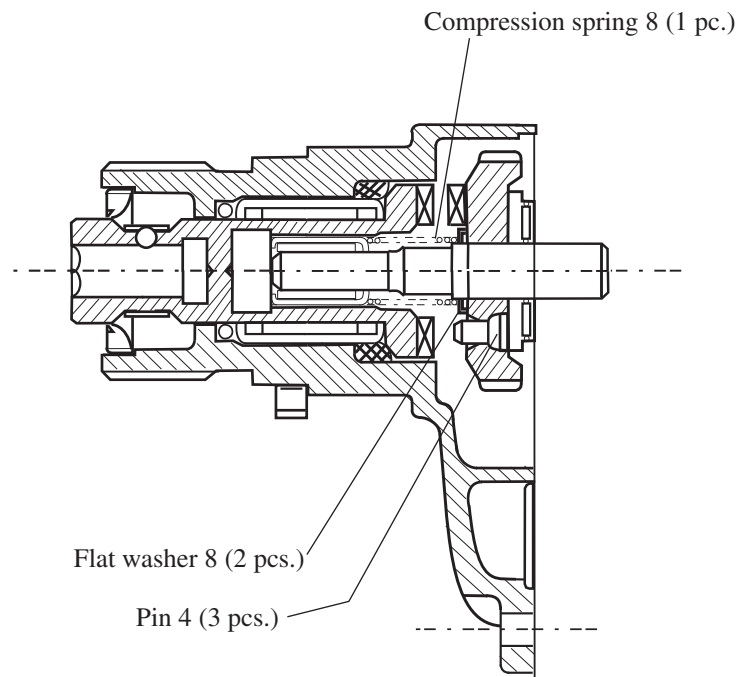

Fig.5

< 6 > Makita grease No.1 have to be applied to the parts illustrated below.
(see Fig.6 and Fig.6A.)

(6823TP)

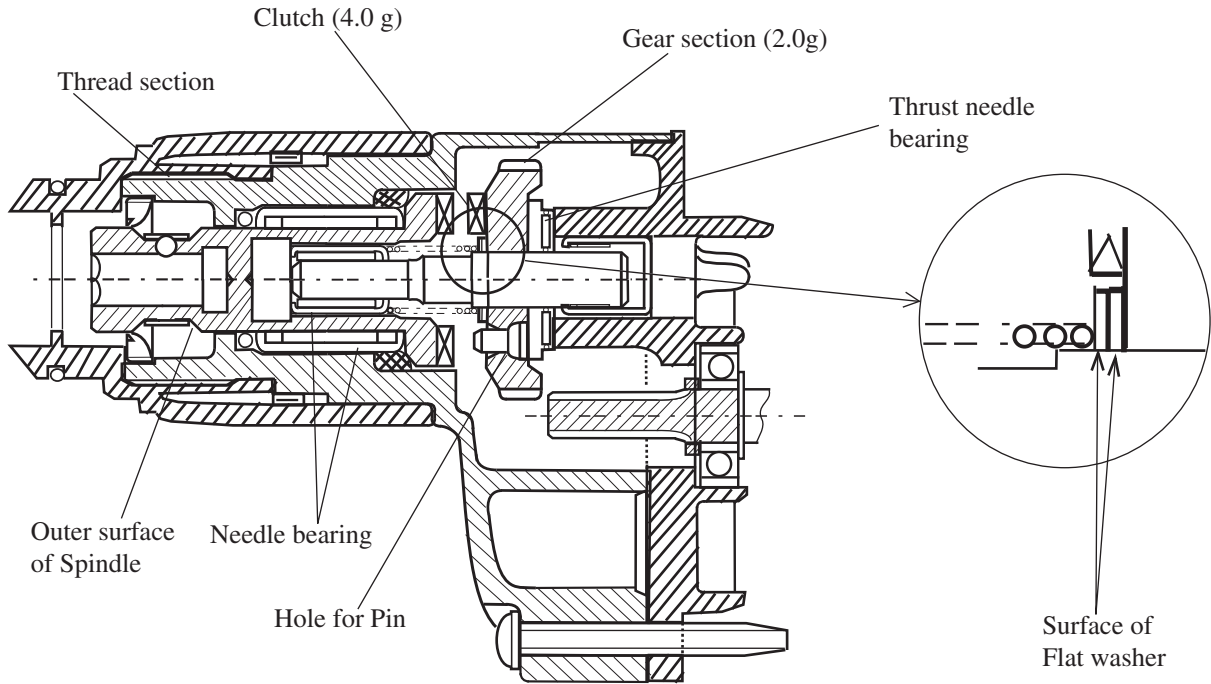

Fig.6

(6824TP, 6825TP)

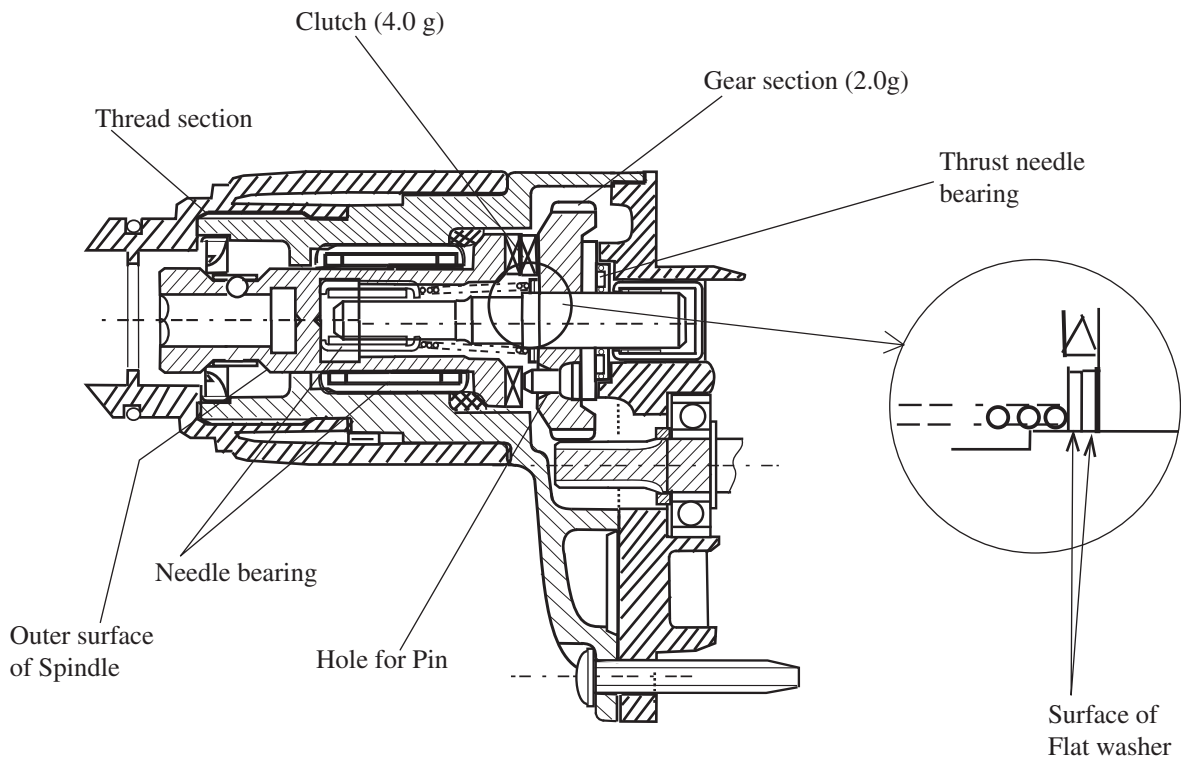

Fig.6A

< 7 > Removing and assembling gear housing cover

(Removing)

Loosen pan head screw M4x8. Pulling out gear housing cover from motor housing by approx. 10mm.

Remove gear housing cover from motor housing.

(Assembling)

Assemble gear housing cover on motor housing with being careful not to damage lead wires.

Fasten it on motor housing with pan head screw M4x8.

(see Fig.7)

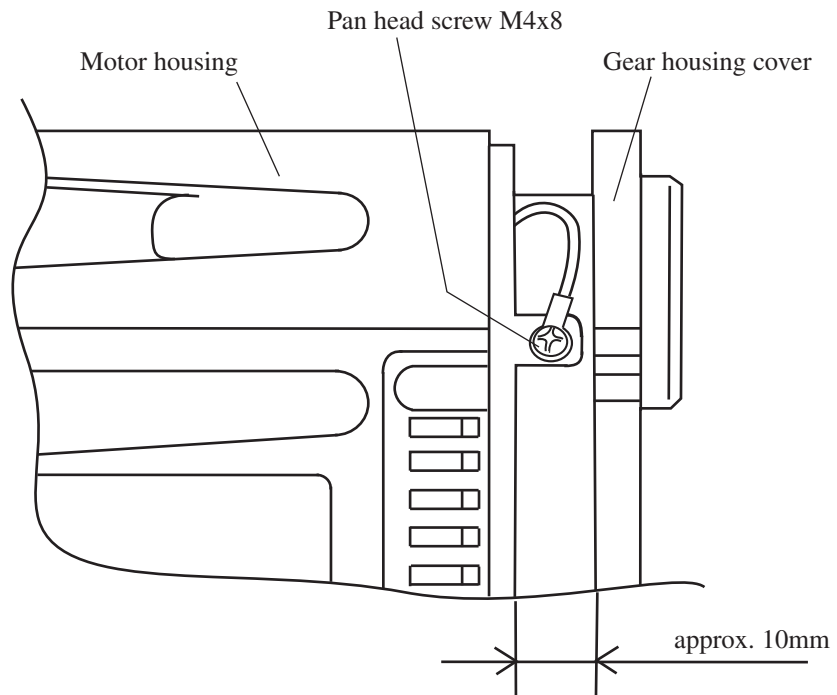
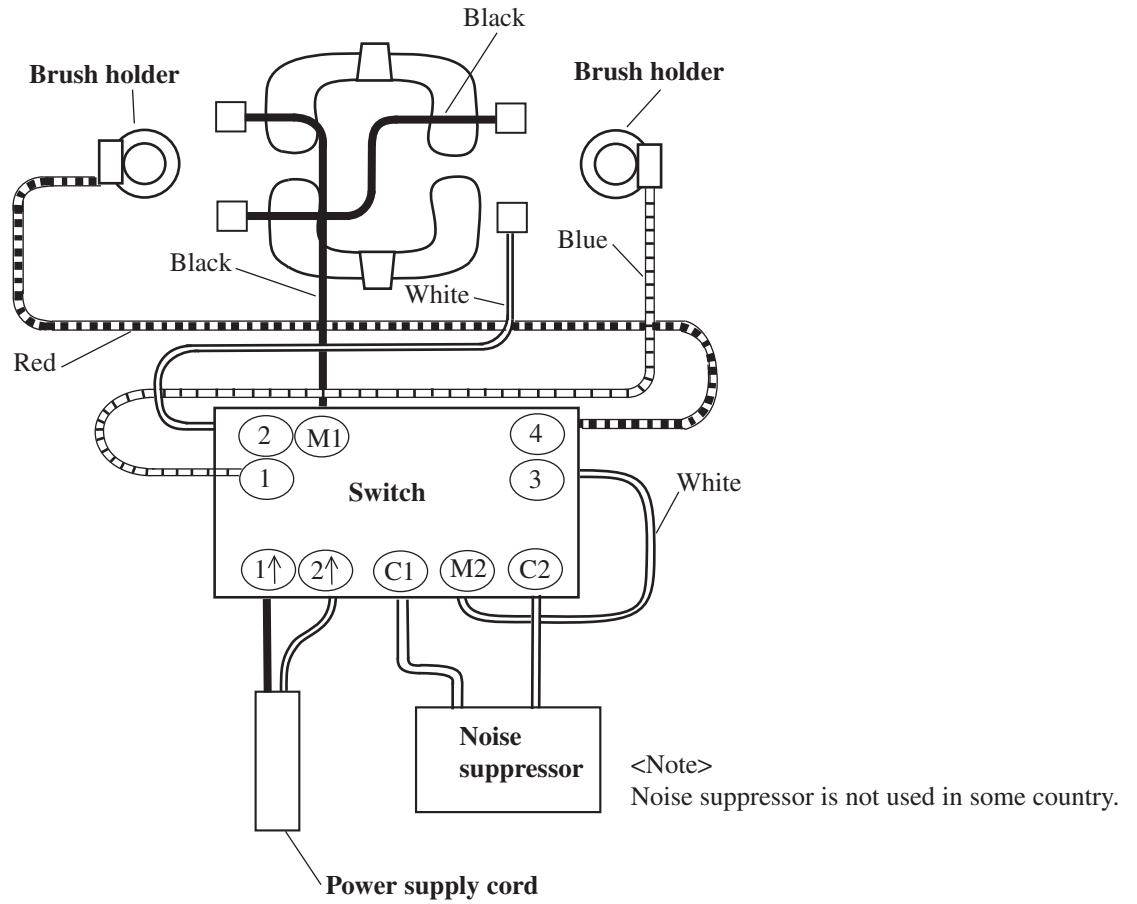

Fig.7

► Circuit diagram

(6823)



(6824, 6825)

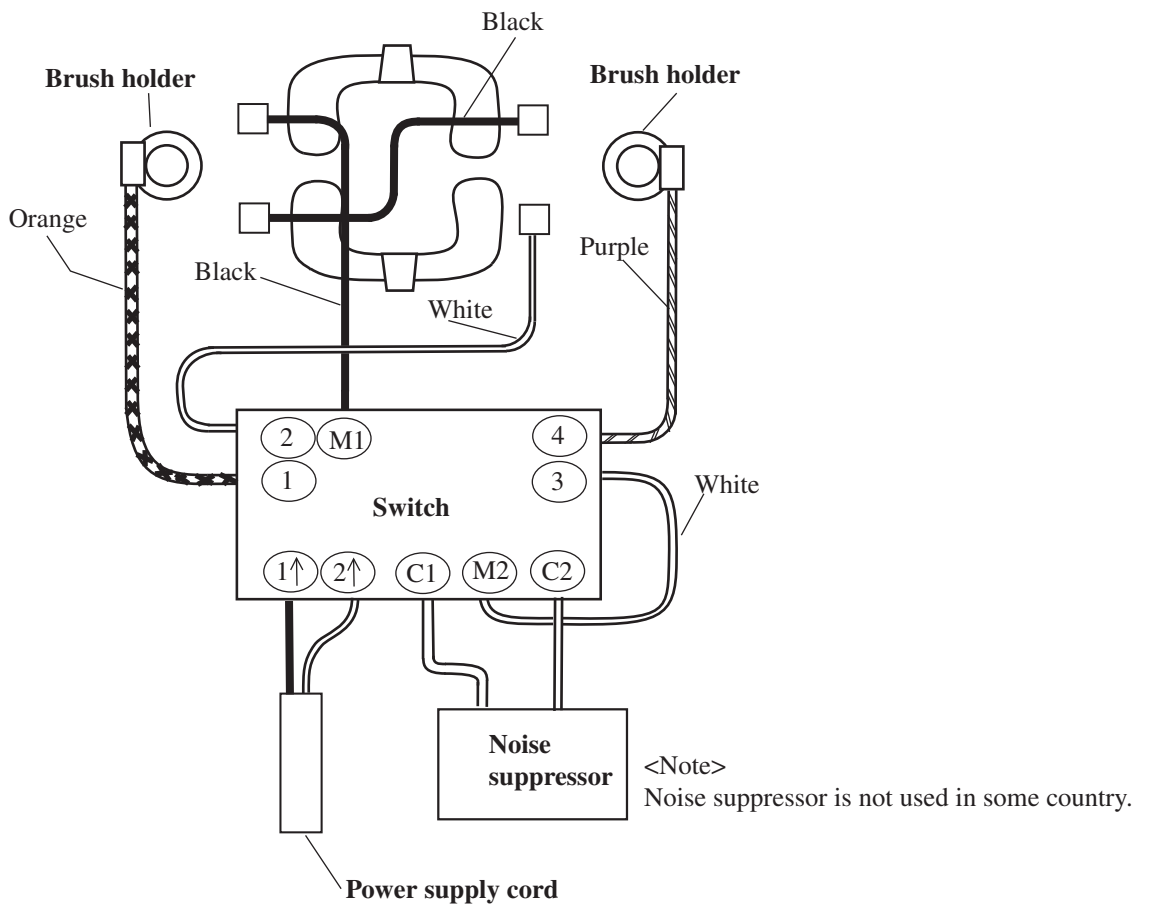

▶ Wiring (6823)

Wiring in upper part of switch

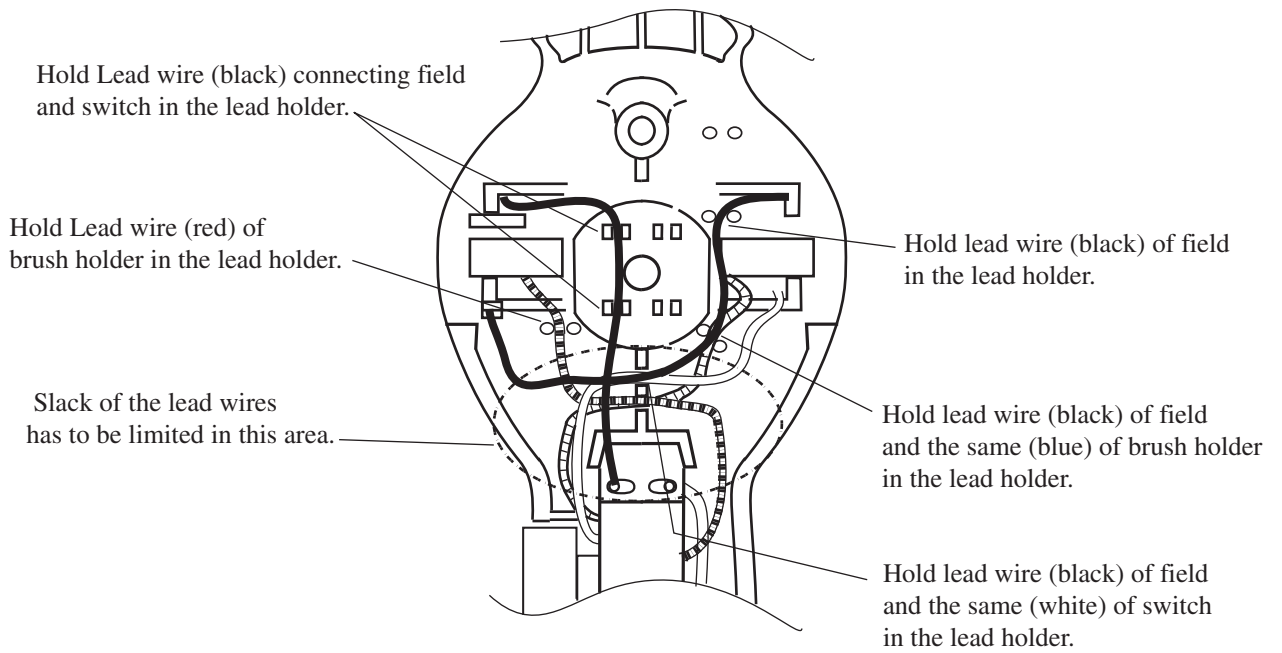

Wiring in lower part of switch

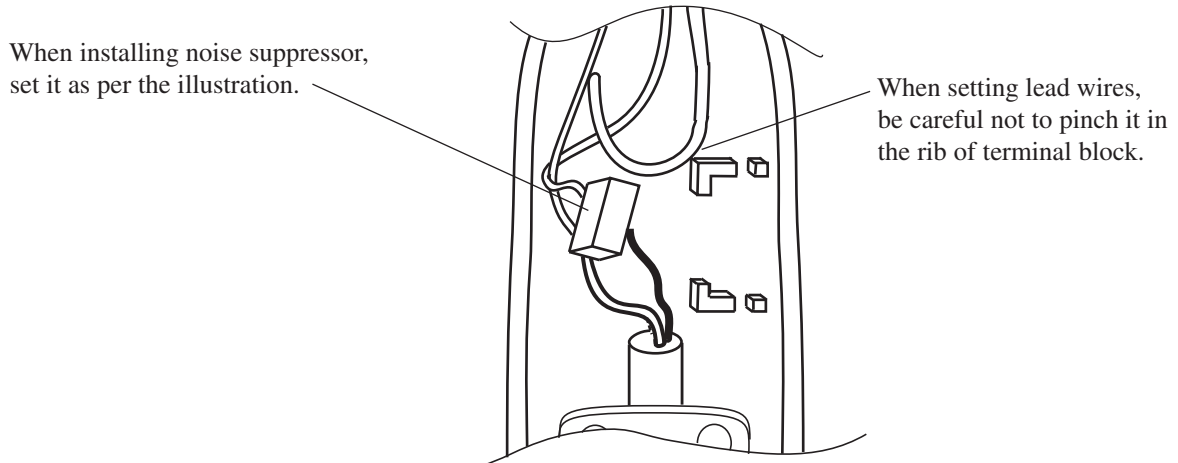

▶ **Wiring**
(6824TP, 6825TP)

Wiring in upper part of switch

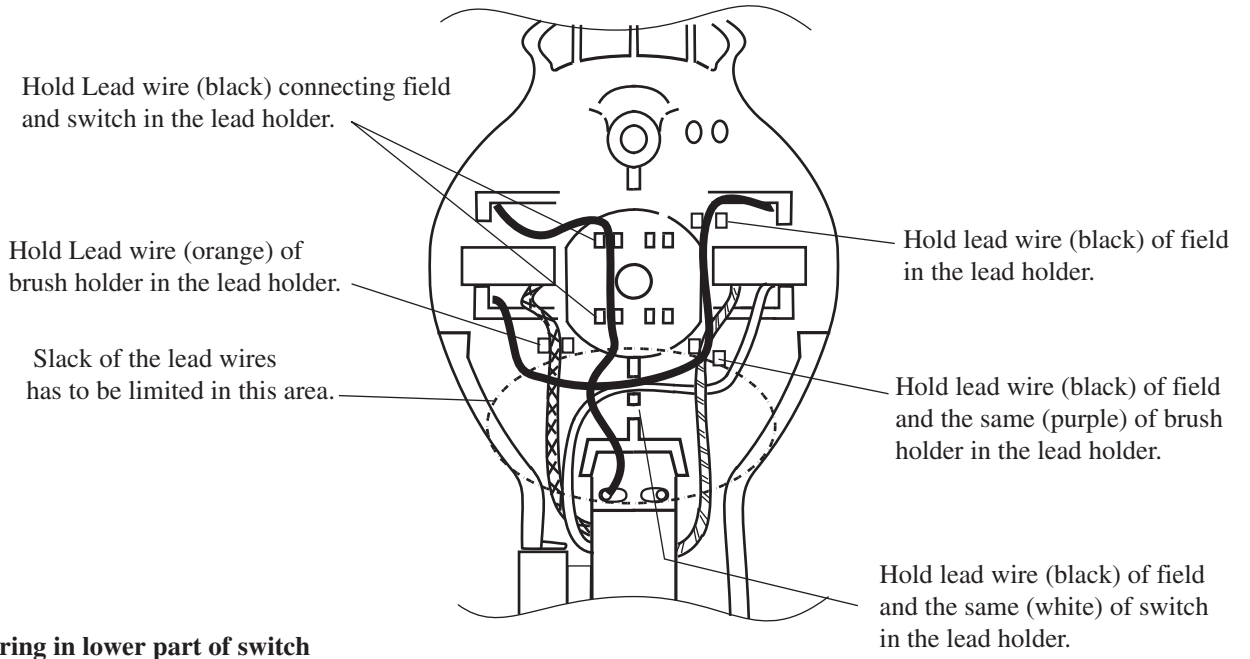

Wiring in lower part of switch

