

**Models No.** ▶ 6830

**Description** ▶ Auto Feed Screwdriver

## CONCEPTION AND MAIN APPLICATIONS

Model 6830 is a screwdriver with a mechanism to feedscrews automatically. So you do not need to do bothersome-by-one setting driving. Shorter tool length, well-balanced design and in-line D-handle assures easier operation.

(Note)

This tool is not offered to some countries and areas. Consult Makita Japan on this matter.

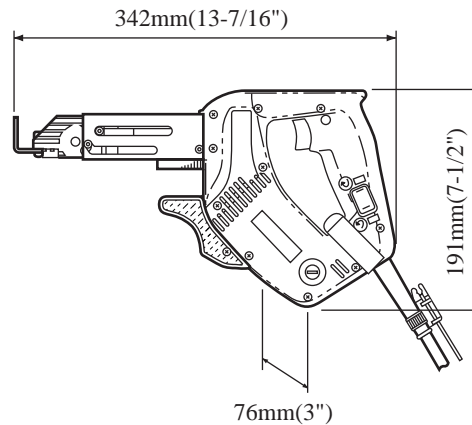

## ▶ Specifications

Voltage (V)	Current (A)	Cycle (Hz)	Continuous Rating (W)		Max. Output(W)
			Input	Output	
100	5.0	50/60	470	220	400
115	4.3	50/60	470	220	400
200	2.5	50/60	470	220	400
220	2.3	50/60	470	220	400
230	2.2	50/60	470	220	400
240	2.1	50/60	470	220	400

### Capacities

<b>Drywall Screw</b>	4mm x 25mm (5/32"x 1")
	4mm x 28mm (5/32"x 1-1/8")
	4mm x 32mm (5/32"x 1-1/4")
	4mm x 40mm (5/32"x 1-9/16")
<b>No Load Speed</b>	0 - 4,700 R/min.
<b>Net Weight</b>	1.9Kg (4.2 lbs.)

## ▶ Standard equipment

Phillips Bit 2-117 (3 pcs.), Hex Wrench 3, Plastic Carrying Case

## ▶ Optional accessories

Phillips Bit 2-117 (5 pcs. per pkg)